

PXG5 is a compact size temperature controller of front panel size 48 × 96 mm. To cope with any of versatile uses as a temperature controller, it has many input/output points and sophisticated control functions.

FEATURES

1. Wide variety and number of input / output
 1. Digital input: Up to 5 points
 2. Digital output: Up to 5 points
 3. Control output: 4 types
Relay contact, SSR drive, voltage linear, current linear
 4. Universal inputs: Thermocouple, resistance bulb, current, voltage, mV linear
 5. Remote SV input function
 6. Analog re-transmission output function (for current or voltage)
 7. Motorized valve control output
2. User interface of easy-to-see indication and easy-to-use operation method
 1. Easy-to-see, large display section
 2. Parameters grouped by functions
 3. User key to which you can assign a function
 4. Password function provided for avoiding wrong operation and protecting settings
 5. Front water-proof structure (IP66 in conformity)
3. Advanced control functions to meet various applications
 1. Sampling cycle 200 ms (300 ms at position feedback control)
 2. Input indication accuracy $\pm 0.3\%$ FS
 3. Manual control function
 4. Control method selectable out of 8 different types: ON/OFF control, PID control, fuzzy PID control, self-tuning control, PID2 control, motorized valve control (with/without position feedback)
 5. Heating/cooling control selectable
 6. Auto tuning function
4. A variety of functions extending the possibility of temperature controller
 1. Guarantee soak function provided, 16 step ramp/soak function
 2. 8 PID setting pallets, 8 SV pallets capable of frequent change of control
 3. Soft start function that limits MV output when starting up
 4. Ramp SV function enables graduate change of SV
 5. Loop burnout alarm, heater burnout alarm and different event outputs are available in digital output (option)
 6. Control standby function
 7. Loader interface (RS232C)
 8. RS485 communication (option)



SPECIFICATIONS

1. General Specifications

- (1) Power supply :
100 V (- 15%) to 240 V (+ 10%) AC,
50/60 Hz
24 V ($\pm 10\%$) DC. 24 V ($\pm 10\%$) AC,
50/60 Hz.
- (2) Power consumption:
12 VA MAX.
- (3) Insulation resistance:
20 M Ω MIN. (at 500 V DC)
- (4) Withstand voltage:
Power source \leftrightarrow all terminals
1500 V AC for 1 min
Relay contact output \leftrightarrow all terminals
1500 V AC for 1 min
Between others 500 V AC for 1 min
- (5) Approvals and certification:
UL(UL873), C-UL(CSA C22.2 No.24-93 or equivalent), CE mark(LVD : EN61010-1, EMC : EN61326-1)

2. Input section

2.1 Process value input

- (1) Number of inputs: 1 point
- (2) Input setting: Programmable scale
- (3) Input signal: See Table 1 (thermocouple, resistance bulb, mV, voltage, , current(With external 250Ω resistance) universal input)
- (4) Standard measurement range and input type: See Table 1
- (5) Indication accuracy (at Ta = 23°C) :
 - Thermocouple input: $\pm 0.3\%FS \pm 1$ digit $\pm 1^\circ C$ or $\pm 2^\circ C$, whichever greater
 - *except:
 - Thermocouple B, 0 to 400°C $\pm 5\%FS \pm 1$ digit $\pm 1^\circ C$
 - Thermocouple R, 0 to 500°C $\pm 1\%FS \pm 1$ digit $\pm 1^\circ C$
 - Thermocouple T, -200 to 0°C $\pm 0.5\%FS \pm 1$ digit $\pm 1^\circ C$
 - Resistance bulb input: $\pm 0.3\%FS \pm 1$ digit or $\pm 0.5^\circ C$, whichever greater
 - mV input, voltage input, current input: $\pm 0.3\%FS \pm 1$ digit
- (6) Indication accuracy by change of temperature: $\pm 0.3\%FS/10^\circ C$
- (7) Indication resolution: See Table 1
- (8) Input sampling cycle: 200 ms (300 ms at position feedback control)
- (9) Input impedance:
 - Thermocouple, mV input: 1 MΩ MIN.
 - Current input: 250 Ω
 - Voltage input: About 1 MΩ
- (10) Variation by signal source resistance:
 - Thermocouple, mV input: $\pm 0.3\%FS \pm 1$ digit per 100 Ω
 - Voltage input: $\pm 0.3\%FS \pm 1$ digit per 500 Ω
- (11) Allowable wiring resistance:
 - Resistance bulb: 10 Ω MAX. (per wire)
- (12) Allowable input voltage:
 - DC voltage input: Between +35 and -10 V
 - Current input: Within ± 25 mA
 - Thermocouple, resistance bulb, mV input: Within ± 5 V
- (13) Noise rejection ratio:
 - Normal mode: 40 dB (50/60 Hz)
 - Common mode: 120 dB (50/60 Hz) From ground, at 220 V AC, 50/60 Hz Between input and output, at 220 V AC, 50/60 Hz
- (14) Input correction:
 - (a) User adjustment: Zero point, span $\pm 50\%FS$ for each
 - (b) Process value shift: $\pm 10\%FS$
 - (c) Input filter: 0.0 to 120.0 sec (filter OFF if set at 0.0)
- (15) Overrange, underrange: Beyond range of -5 to 105% (accuracy not guaranteed between -5 and 0, and between 100 and 105%FS)

2.2 Auxiliary analog input (remote SV input)

- (1) Number of inputs: Up to 1 point
- (2) Input signal: Voltage, 0 to 5 V DC /1 to 5 V DC
- (3) Input impedance: About 1 MΩ
- (4) Sampling rate: 800ms (600ms at Position feed back control)

2.3 Heater current detector (CT) input

- (1) Input type: Single phase CT Up to 1 point max. For 1 to 30 A: CTL-6-S-H For 20 to 50 A: CTL-12-S36-8F
- (2) Range of detected current: 1 to 50A
- (3) Detected current accuracy: Setting $\pm 10\%FS$
- (4) Detected current resolution: 0.1 A
- (5) ON time necessary for detection: 800 ms MIN.

2.4 Digital input (DI)

- (1) Number of points: Up to 5 points (up to 3 points for motorized valve control output)
- (2) Specifications: No-voltage contact or transistor input
- (3) Contact capacity: 30 V DC, about 3 mA (per point)
- (4) Input judgment: ON assumed at 1 kΩ or lower (contact) or 5 V DC or lower (transistor) OFF assumed at 100 kΩ or higher (contact) or 18 V DC or higher (transistor)
- (5) Sampling pulse width: 200 ms MIN. (300 ms MIN. at position feedback control)
- (6) Functions: Remote mode selection, SV changeover, control standby, AT startup, timer startup, alarm unlatch, Program selection, start / stop / reset, PID switching (normal/reverse), etc.

2.5 Valve position feedback signal (potentiometer) input

- (1) Resistance range: 100 Ω to 2.5 kΩ, 3 wire type
- (2) Resolution: 0.5%FS
- (3) Input accuracy: $\pm 1.0\%FS$
- (4) Effect of temperture variation: $\pm 0.5\%FS/10^\circ C$
- (5) Burnout detection: none

3. Output section

3.1 Control output

(1) Number of points:

Up to 2 points (2 points: Heating/cooling control)

(2) Type:

selected out of [1] to [5] below

[1] Relay contact output

- Proportional cycle: 1 to 150 sec
- Contact structure: 1 NO (SPST) contact
- Contact capacity
220 V AC/30 V DC, 3 A (resistive load)
220 V AC/30 V DC, 1 A (inductive load)
- Minimum Open/Close current: 100 mA (24 V DC)
- Mechanical life: 20 million operations MIN. (100 operations/min)
- Electrical life: 100,000 operations MIN. (rated load)

[2] SSR/SSC drive output

- Proportional cycle: 1 to 150 sec
- ON voltage: 20 V DC (18 to 24 V DC)
- OFF voltage: 0.5 V DC or lower
- Maximum current: 20 mA DC (for each of outputs 1 and 2)
- Load resistance: 850 Ω MIN.

[3] Current output (0 to 20 mA DC/4 to 20 mA DC)

- Accuracy: $\pm 5\%$ FS
- Linearity: $\pm 5\%$ FS
- Load resistance: 600 Ω MAX.

[4] Voltage output (0 to 5 V DC/1 to 5 V DC/0 to 10 V DC/2 to 10 V DC)

- Accuracy: $\pm 5\%$ FS
- Linearity: $\pm 5\%$ FS
- Load resistance: 10 k Ω MIN.

[5] Motorized valve control output

- Contact structure: 2 NO (SPST) contacts
- Contact capacity: 220 V AC/30 V DC, 1 A
- Minimum ON/OFF current: 100 mA (24 V DC)
- Mechanical life: 20 million operations MIN. (100 operations/min)
- Electrical life: 100,000 operations MIN. (rated load)
- Output interlock: Output interlock circuit provided

3.2 Digital output (DO)

(1) Number of outputs:

Relay contact output

Up to 3 points (shared common)

Up to 2 points (independent common)

Transistor output

Up to 2 points

(2) Output specifications:

(1) Relay contact output

Contact structure: 1 NO (SPST) contact

Contact capacity: 220 V AC/30 V DC, 1 A

Minimum ON/OFF current: 100 mA (24 V DC)

Mechanical life: 20 million operations MIN. (100 operations/min)

Electrical life: 100,000 operations MIN. (rated load)

(2) Transistor output

Contact type: Open collector

Rated values: 30 V DC, 100 mA

ON voltage: 1V or lower

(3) Output functions:

Alarm output (see "Alarm function")

Main unit control mode output, program status output, etc.

(4) Output cycle: 200ms (300ms at Position feedback control)

3.3 Auxiliary analog output (re-transmission output)

(1) Number of points: 1 point

(2) Type:

Current/voltage output (0 to 20 mA DC/4 to 20 mA DC/0 to 5 V DC/1 to 5 V DC/0 to 10 V DC/2 to 10 V DC)

- Guaranteed output range: 0 to 20.6 mA DC/0 to 10.3 V DC

- Accuracy: $\pm 0.2\%$ FS ($\pm 5\%$ FS at 1 mA or smaller)

- Linearity: $\pm 0.2\%$ FS ($\pm 5\%$ FS at 1 mA or smaller)

- Resolution: 5000 MIN.

- Load resistance 600 Ω MAX. (current)
10 k Ω MIN. (voltage)

(3) Output update cycle:

200ms (Position feedback type: 300ms)

(4) Output contents:

PV, SV, DV, MV

(5) Additional function:

Scaling function

(6) Restriction: Cannot be selected when control output 2 is used.

4. Indication/setting section

4.1 Display unit

(1) Type: LED

(2) Indication contents:

Process value indication: 7 segments, 4 digits [red]

Setpoint indication: 7 segments, 4 digits [green]

Indication status: 6 indicator lamps

4.2 Setting section

(1) Type: Sheet type keys (with emboss)

(2) Number of keys: 4 keys.

, , plus user function key

5. Control functions

5.1 Control types

- (1) 2-position control (set parameter P to 0%)
- (2) PID control (fuzzy PID included)
 - PID parameters determination: Auto tuning, Selftuning
- (3) PID dual (heating, cooling) function (fuzzy PID included)
 - PID parameters determination: Auto tuning
- (4) Motorized valve control (position feedback or servo control)
 - Full stroke time: 30 sec MIN.

5.2 Control parameters

- **Proportional band (P):**
0.0 to 999.9%. 2-position control when P = 0.
- **Integral time (I):** 0 to 3200 sec. Integral time control invalidated when I = 0.
- **Differential time (D):**
0.0 to 999.9 sec. Differential time control invalidated when D = 0.
- **Control cycle:** 200 ms (300 ms at position feedback control)
- **Anti-reset windup:**
0 to 100% of measurement range
- **Hysteresis band:**
50% of measurement range (at 2-position control only)
- **Number of SV and PID combinations:**
8 combinations.
Changed by any of parameter setting, digital input, communication and user function keying

5.3 Control mode

- (1) **Mode type:** Auto, Manual, Remote
* In case of 2 position control in manual mode, 2 positions correspond to MV = 100 or 0%.
- (2) **Mode changeover:**
Auto↔Manual: Balanceless · bumpless
Auto/Manual→Remote: Balance · bumpless
Auto/Manual←Remote: Balance · bumpless

6. Alarm function

6.1 Number of alarm setting points

- Up to 5 points (depends on number of DO)

6.2 Alarm type

- **Process value (upper limit/lower limit, absolute/deviation, range), main unit error, etc.**
(non-excitation, delay, latch, timer function option provided)

6.3 Heater burnout alarm function

- (1) **Detectable range:**
1 to 50 A
- (2) **Detected current resolution:**
0.1 A
- (3) **Setting resolution:**
0.1 A
- (4) **Hysteresis:** 0.0 to 50.0 A

7. Communication function

7.1 RS-485 interface

- (1) **Number of points:** 1 point
- (2) **Physical specifications:** EIA RS485
- (3) **Protocol:** Modbus-RTU
- (4) **Communication method:**
Half duplex bit serial, Asynchronous communication
- (5) **Code type:** Data length 8 data bits. Parity Odd, even, none.
- (6) **Communication rate:**
9600 bps, 19200 bps
- (7) **Connection status:**
Up to 32 units connectable including multi-drop master function
- (8) **Communication distance:**
Up to 500 m (total connect extension)

8. Processing at power failure

- **Memory protection:**
Protect by non-volatile memory

9. Self-diagnosis

- **Method:** Program error supervision by watchdog timer

10. Operation and storage conditions

- (1) **Operating ambient temperature:**
-10 to 50°C
- (2) **Storage temperature:**
-20 to 60°C
- (3) **Operating/storage ambient humidity:**
90%RH MAX. (no condensing)
- (4) **Warm-up time:**
30 min MIN
- (5) **Vibration:** 10 to 70 Hz, 9.8 m/s² (1 G) MAX.
- (6) **Impact:** 49 m/s² (5 G) MAX.

11. Structure

- (1) **Mounting method:**
Mounted with panel
- (2) **External terminals:**
Screw terminals, M3
- (3) **Case:**
 - Material: ABS, and degeneration PPO
 - Non-combustibility grade: UL94V-0 equivalent
 - Color: Black
- (4) **Protection structure:**
 - Panel front side: IP66, NEMA-4X equivalent (if panel is mounted using our genuine packing. Not water-proof if mounted closely together.)
 - Body: IP20 equivalent (slits on top and bottom)
 - Terminals: IP00 equivalent. Terminal cover can be mounted optionally.
- (5) **Dimensions:** 48 (W) × 96 (H) × 80 (D) mm
- (6) **Mass:** About 300 g

12. Scope of delivery

- Controller: 1 unit
- Instruction manual: 1 copy
- Fixture: 2 pcs
- Water-proof packing: 1 pc
- Shunt resistor: 1 pc
- Unit nameplate: 1 pc

13. User customize function

13.1 Program (ramp/soak) function

(1) Number of program steps:

- 16 steps × 1 pattern,
 - 8 steps × 2 patterns, or
 - 4 steps × 4 patterns
- (1 step = 2 segments)

(2) Control option:

- Control by digital input
- Status output by digital output

(3) Basic function:

- [1] Segment time can be set in "Hour, Minutes" or "Minutes, Seconds"
- [2] Guarantee soak
- [3] Repeat action
- [4] PV start
- [5] Delay start
- [6] Power failure restoring function

(4) Memory backup:

- EEPROM

13.2 User functions

- Pressing the user key can perform Auto/Manual change, Standby ON/OFF change, remote SV change, ramp/soak change or other function as assigned

13.3 Password function

- 3 level password function

CODE SYMBOLS

Standard type

Digit	Specifications	Note	1	2	3	4	5	6	7	8	9	10	11	12	13
4	<Front panel size W × H> 48 × 96mm		P	X	G	5									
5	<Output 1> Relay contact SSR drive Current (0 to 20 mA DC/4 to 20 mA DC) Voltage (0 to 5 V DC/1 to 5 V DC/0 to 10 V DC/2 to 10 V DC)	Note1 Note1					A	C	E	P					
6	<Output 2> None Relay contact SSR drive Current (0 to 20 mA DC/4 to 20 mA DC) Voltage (0 to 5 V DC/1 to 5 V DC/0 to 10 V DC/2 to 10 V DC) Re-transmission output, current (0 to 20 mA DC/4 to 20 mA DC) Re-transmission output, voltage (0 to 5 V DC/1 to 5 V DC/0 to 10 V DC/2 to 10 V DC)	Note3 Note3 Note3 Note3 Note3 Note3					Y	A	C	E	P	R	S		
7	<Option 1> None RS485 Digital input (No.1) + Digital input (No.2) Digital input (No.1) + RSV1 Digital input (No.1) + CT1 RS485 + Digital input (No.1) RS485 + RSV1 RS485 + CT1 RS485 + Digital input (No.1) + RSV1 Digital input (No.1) + RSV1 + Digital input (No.2)	Note2 Note1 Note4 Note5 Note2 Note1 Note4 Note5 Note2 Note3 Note3					Y	M	T	H	G	V	K	J	F
8	<Revision symbol>									1					
9	<Digital output> (relay contact output) None Digital output 1 point (No.1) Digital output 2 points (No.1,2) Digital output 3 points (No.1,2,3) Digital output 2 points [independent common] (No. 1, 2)	Note4									0	1	F	M	J
10	<Power source, instruction manual> 100 to 240 V AC, no instruction manual 100 to 240 V AC, Japanese instruction manual 100 to 240 V AC, English instruction manual 24 V AC/DC, no instruction manual 24 V AC/DC, Japanese instruction manual 24 V AC/DC, English instruction manual										N	Y	V	C	A
11	<Option 2> None Digital input (No.3,4,5) + CT2 Digital input (No.3,4,5) Digital input (No.3,4,5) + digital output (No.4,5) [transistor output] Digital input (No.3,4,5) + RSV2	Note1 Note4 Note5 Note2									Y	A	B	C	D
12	None													0	0
13															

Note 1: If output 1 was for current or voltage output, option cannot be assigned to CT1 nor CT2.
(If 7th digit was assigned to G or J, or 11th digit to A, 5th digit cannot be assigned to E nor P.)

Note 2: RSV1 in option 1 and RSV2 in option 2 cannot be assigned simultaneously.
(If 7th digit was assigned to H, K, F, 2 11th digit cannot be assigned to D.)

Note 3: In case, in option 1, of DI 2 points + RSV1 or RS485 + DI 1 + RSV1, output 2 cannot be assigned.
(If 7th digit was assigned to F or 2, 6th digit cannot be assigned to A, C, E, P, R, nor S .)

Note 4: In case of CT1 in option 1, or CT2 in option 2, digital output cannot be assigned to None.
(If 7th digit was assigned to G or J, or 11th digit to A, 9th digit cannot be assigned to 0.)

Note 5: CT1 in option 1 and CT2 in option 2 cannot be selected simultaneously.
(If 7th digit was assigned to G or J, 11th digit cannot be assigned to A.)

CODE SYMBOLS

Motorized valve control type

Digit	Specifications	Note	1	2	3	4	5	6	7	8	9	10	11	12	13	← Digit
4	<Front panel size W × H> 48 × 96mm		P	X	G	5										
5	<Output 1> Motorized valve control output (Without PFB) Motorized valve control output (With PFB)						S	V								
6	<Output 2> None Auxiliary Digital output						Y	A								
7	<Option 1> None Digital input (No.1,2,3) + RSV1 RS485 + Digital input (No.1,2,3) RS485 + Digital input (No.1) + RSV1						Y	E	U	F						
8	<Revision symbol>									1						
9	<Digital output> (relay contact output) None Digital output 1 point (No.1) Digital output 2 points (No.1,2) Digital output 3 points (No.1,2,3) Digital output 2 points [independent common] (No. 1, 2)										0	1	F	M	J	
10	<Power source, instruction manual> 100 to 240 V AC, no instruction manual 100 to 240 V AC, Japanese instruction manual 100 to 240 V AC, English instruction manual 24 V AC/DC, no instruction manual 24 V AC/DC, Japanese instruction manual 24 V AC/DC, English instruction manual										N	Y	V	C	A	B
11	<Option 2> None											Y				
12	None												0	0		
13																

OPTIONALLY ITEMS

Instruction manual for communication functionRS485 (Modbus)	Type:INP–TN514450–E
Current detector for heater burnout alarm (CT)	1 to 30A Type:ZOZ *CCTL–6–S–H
	20 to 50A Type:ZOZ *CCTL12–S36–8F
Rear terminal cover	Type:ZZPPXR1–B230
Shunt resistor 250Ω ± 0.1%	Type:ZZPPXR1–A190
PC loader communication cable	Type:ZZP PXH1 *TK4H4563

TABLE 1

[1] Unit of temperature: °C

Input type	Input code	Measurement range [°C]		Indication/setting resolution [°C]		
		Max.	Min.	Max.	Min.	
Resistance bulb	JPt100Ω	0	-150 to 600	0 to 150	1	0.1
	Pt100Ω	1	-200 to 850	0 to 150	1	0.1
Thermocouple	J	2	0 to 1000	0 to 400	1	0.1
	K	3	0 to 1200	0 to 400	1	0.1
	R	4	0 to 1600		1	
	B	5	0 to 1800		1	
	S	6	0 to 1600		1	
	T	7	-200 to 400	-200 to 200	0.1/1	
	E	8	-200 to 800	0 to 800	1	0.1/1
	N	12	0 to 1300		1	
	PL-II	13	0 to 1300		1	
	Unusable	14	—	—	—	—
DC voltage	DC0 to 5V	15	-1999 to 9999 (Range where scaling is allowed)		1/1000 digit	
	DC1 to 5V	16				
	DC0 to 10V	17				
	DC2 to 10V	18				
	DC0 to 100mV	19				
DC current	DC0 to 20mA	15				
	DC4 to 20mA	16				

[2] Unit of temperature: °F

Input type	Input code	Measurement range [°F]		Indication/setting resolution [°F]		
		Max.	Min.	Max.	Min.	
Resistance bulb	Pt100Ω	1	-238 to 1562	32 to 302	1	0.1
Thermocouple	J	2	32 to 1832	32 to 752	1	0.1
	K	3	32 to 2192	32 to 752	1	0.1
	R	4	32 to 3272		1	
	B	5	32 to 3272		1	
	S	6	32 to 2912		1	
	T	7	-328 to 752	-328 to 392	1	
	E	8	-328 to 1472	32 to 1472	1	
	N	12	32 to 2372		1	
	PL-II	13	32 to 2372		1	
	Unusable	14	—	—	—	—
DC voltage	DC0 to 5V	15	-1999 to 9999 (Range where scaling is allowed)		1/1000 digit	
	DC1 to 5V	16				
	DC0 to 10V	17				
	DC2 to 10V	18				
	DC0 to 100mV	19				
DC current	DC0 to 20mA	15				
	DC4 to 20mA	16				

* Input a DC current to 1 to 5 V DC or 0 to 5 V DC range via external resistor of 250 Ω.
* Input type and ranges are standardly factory set as follows.
K: 0 to 400°C
Pt, JPt: 0 to 150°C
Voltage, current: 0 to 100%
Standard input type is thermocouple K.

OUTLINE DIAGRAM (Unit : mm)

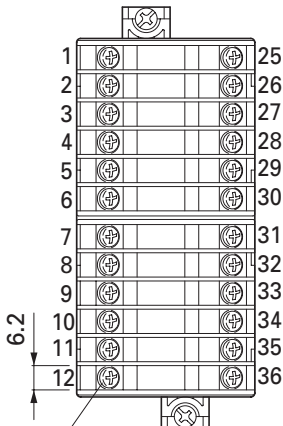
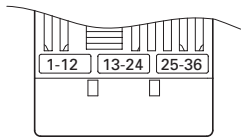
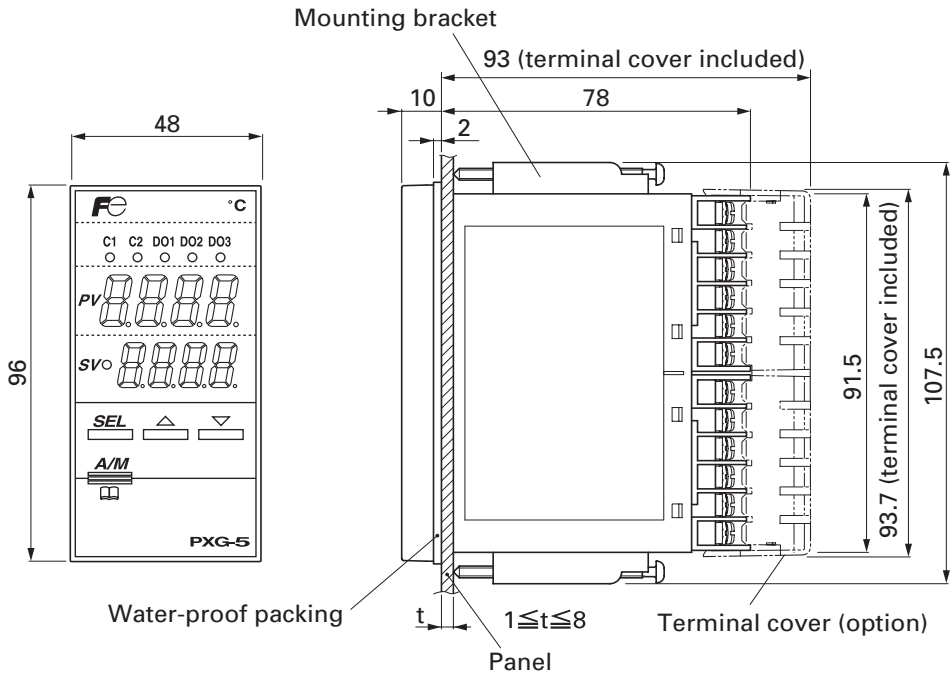

Terminal screw M3

PC loader interface

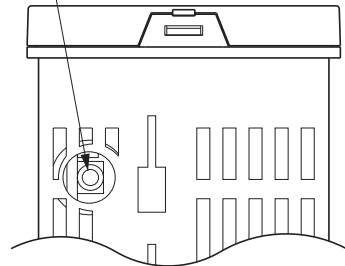

Panel cutout size

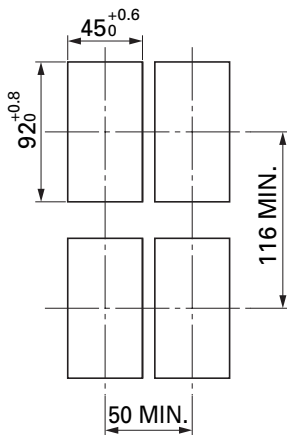

Side stick mounting (n units)
(water-proof property is lost in this case)

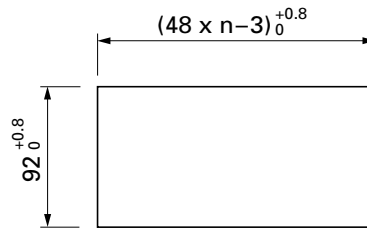

Mass about 0.3 kg

OPTIONALLY ARRANGED ARTICLES

Heater current detector (CT)

. Specification : 1 to 30 A
 . Type : CTL-6-S-H

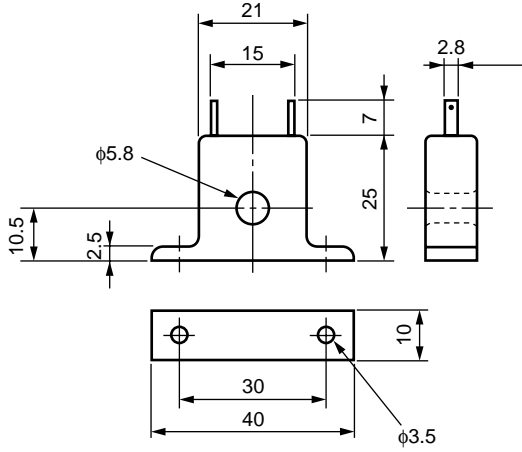

. Specification : 20 to 50 A
 . Type : CTL-12-S36-8F

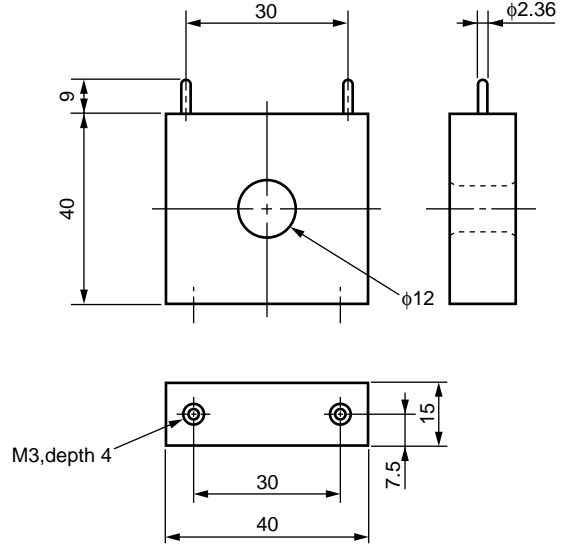

Note 1) Detection is available only for single phase heater.
 Note 2) Unusable for heater control by thyristor phase angle control.

EXTERNAL CONNECTION DIAGRAM

Standard type with communication

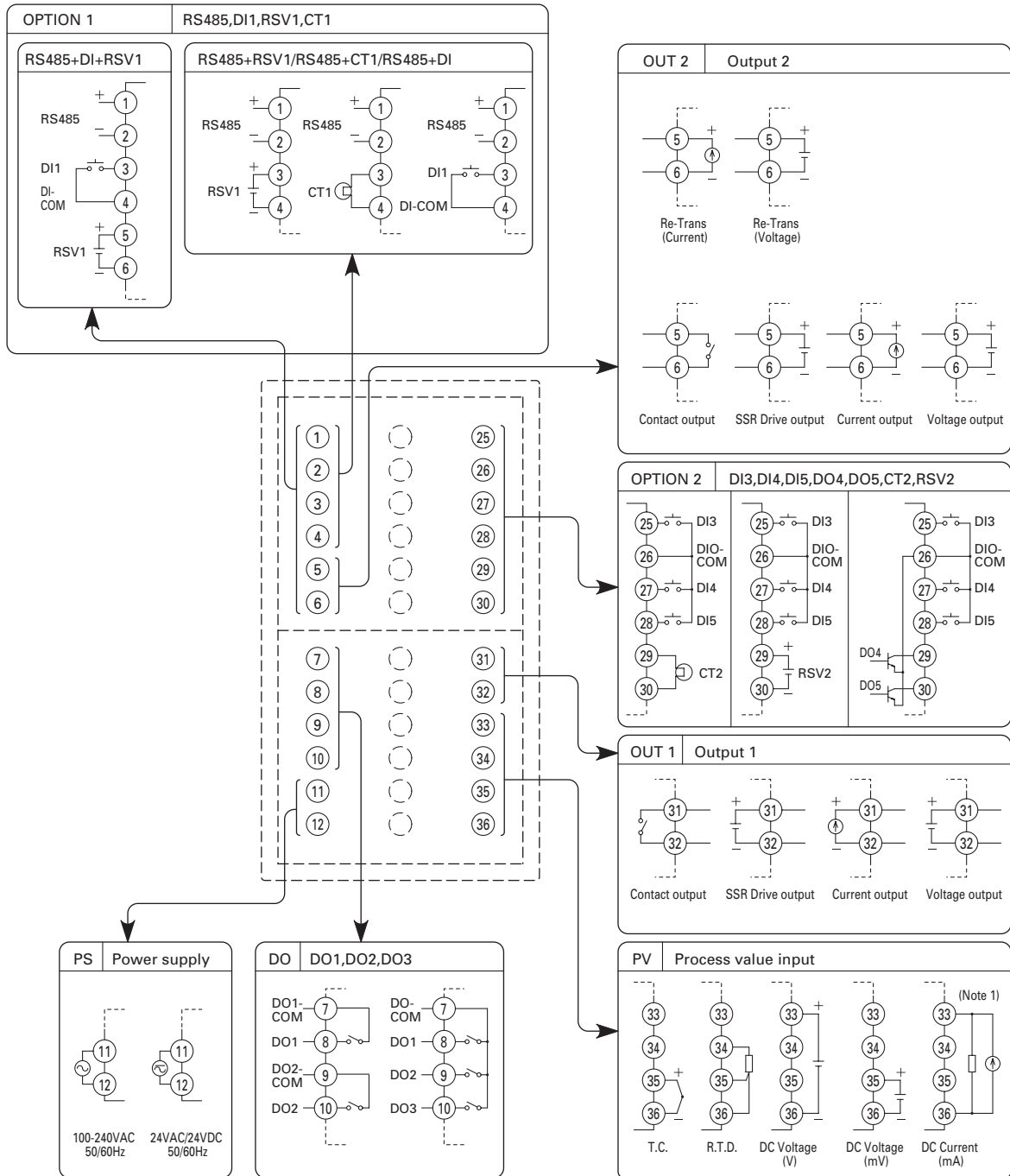

Note 1: Connect the furnished resistor to (33) and (36).

Standard type without communication

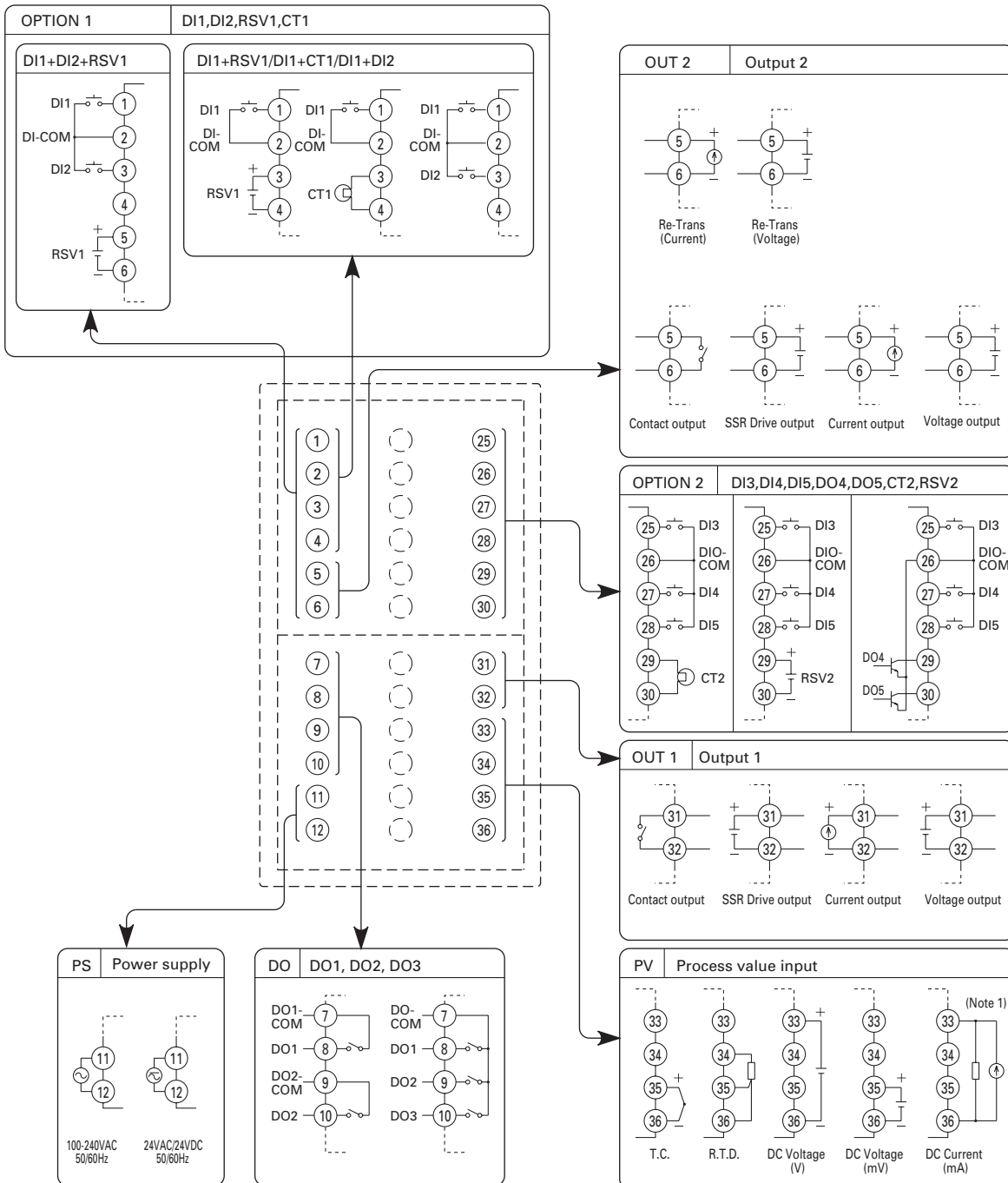

Motorized valve control type with communication

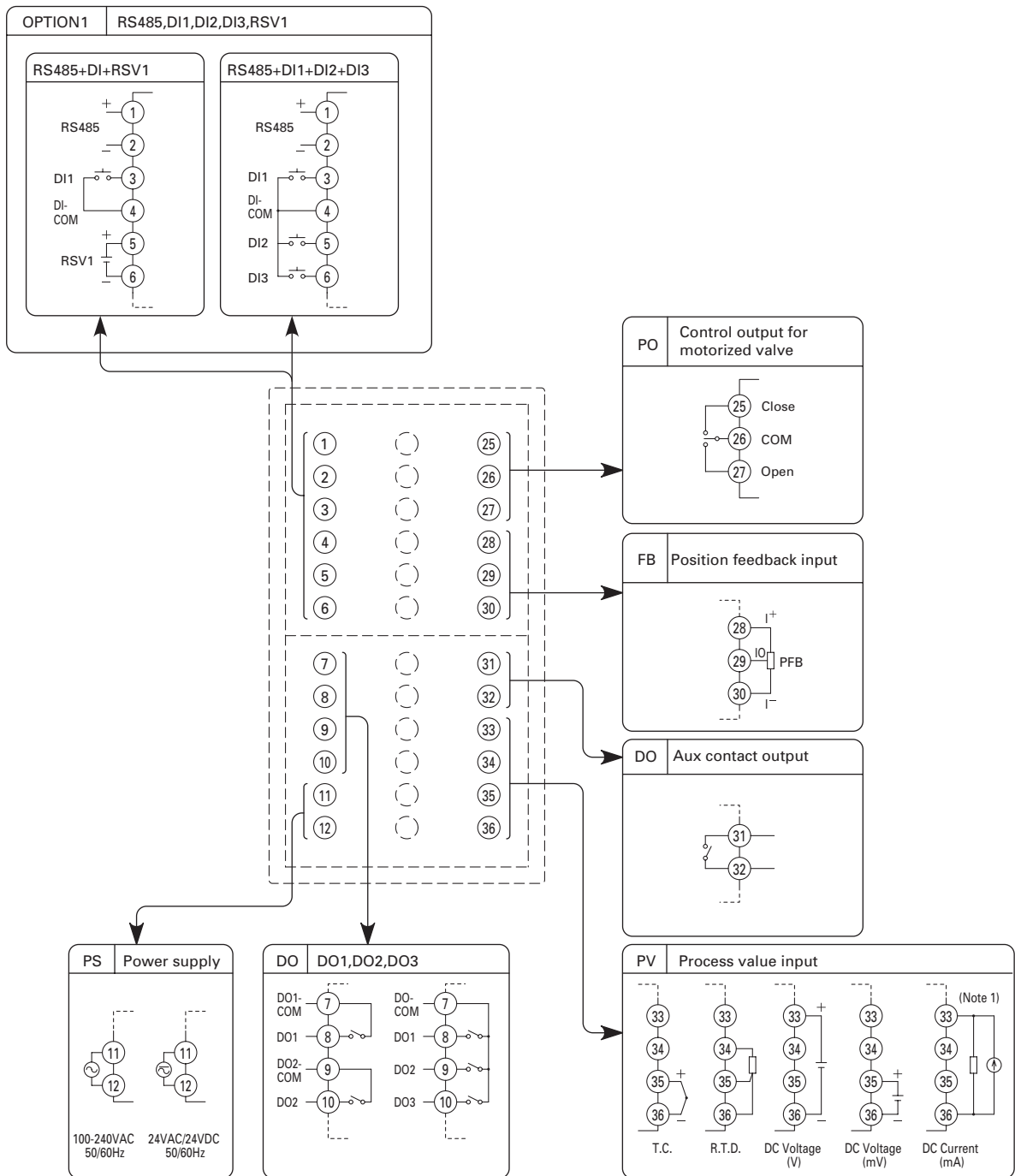

Note 1: Connect the furnished resistor to ③③ and ③⑥ .

Motorized valve control type without communication

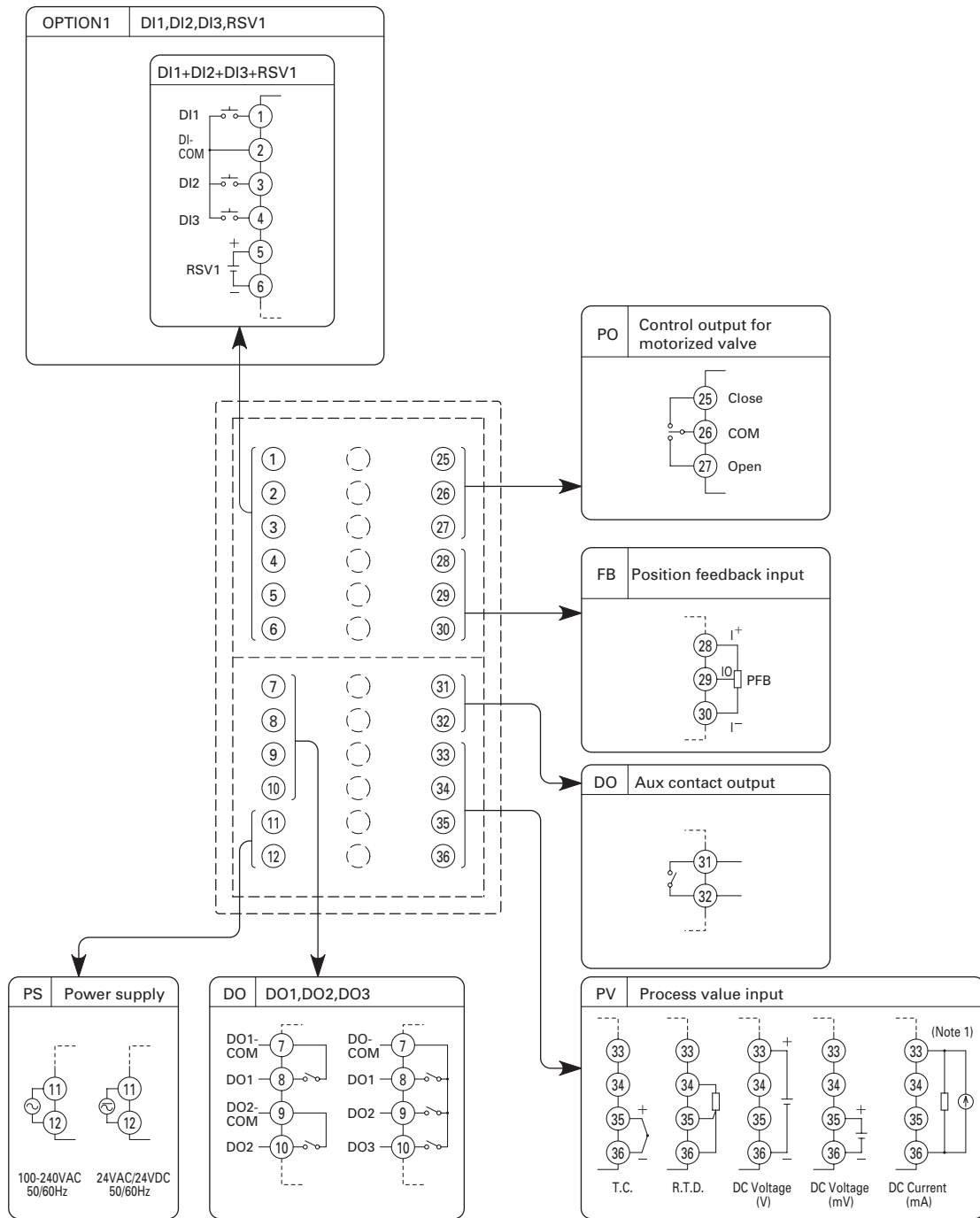

Note 1: Connect the furnished resistor to 33 and 36 .

ISOLATED BLOCK DIAGRAM

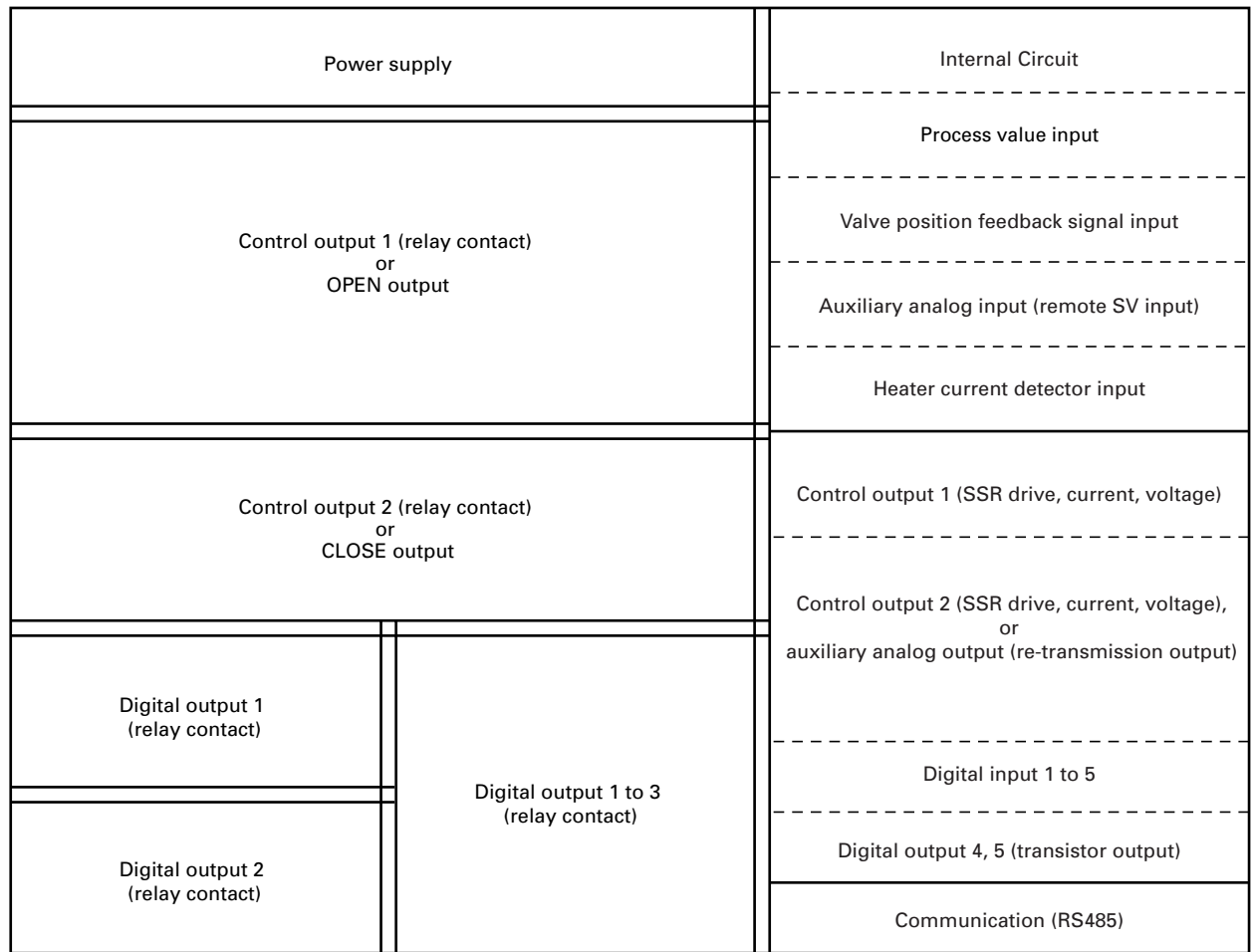

When the 9th digit of the code symbols = J
(DO1, 2 independent common)

When the 9th digit of the code symbols = Other than J
(DO1 to 3 shared common)

==== : Basic insulation (1500 V AC)

_____ : Functional insulation (500 V AC)

- - - - - : Non-insulation

⚠ Caution on Safety

*Before using this product, be sure to read its instruction manual in advance.

Fuji Electric Co., Ltd.

**International Sales Div
Sales Group**

Gate City Ohsaki, East Tower, 11-2, Osaki 1-chome,
Shinagawa-ku, Tokyo 141-0032, Japan

<http://www.fujielectric.com>

Phone: 81-3-5435-7280, 7281 Fax: 81-3-5435-7425

<http://www.fjielecric.com/products/instruments/>