

# TURBO BLOWERS

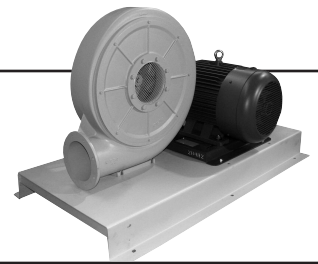

These Belt Driven Blower packages are provided with cast aluminum blower housings and aluminum closed impellers. The Blowers are provided in a clockwise rotation. Blower housing position may be changed from Horizontal to vertical discharge. Counter clockwise rotation may be provided. High performance V-belt pulley design provides compact design. All units are provided with mounting base and belt guard.

### APPLICATIONS:

A few of the many applications are:

- Forced ventilation of control cabinets.
- Conveying of air at high system resistance
- Forced Air Supply for gas, oil and coal fired systems.
- Drying of ink for silkscreen and printing machines.
- Air Supply for air cushion tables.

### PERFORMANCE CURVES

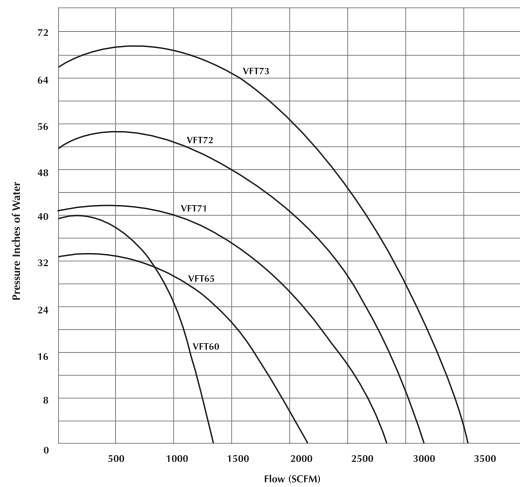

### VFT60

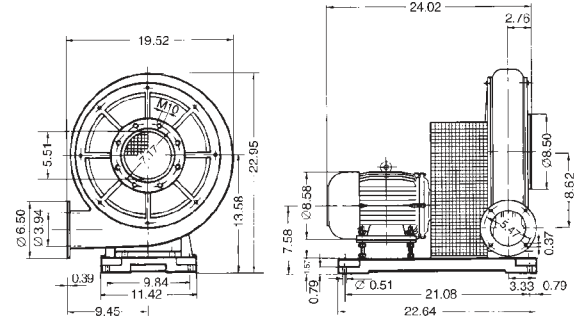

### VFT65

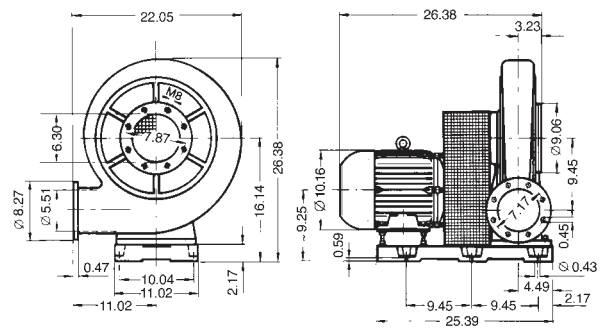

### VFT71 / 72 / 73

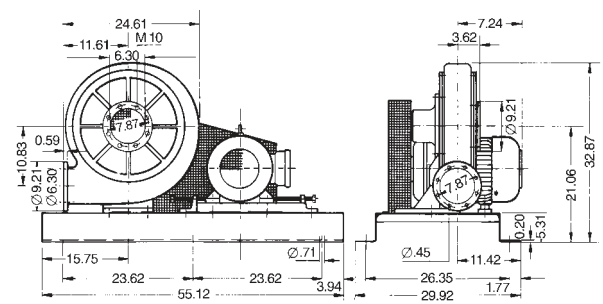

Blower Model	Motor HP	Voltage	Phase	Frequency	Rated Current at 230/460V	Maximum Pressure inch H <sub>2</sub> O	Maximum Flow SCFM	Weight lbs/kg
VFT60	7.5	230/460V	3Φ	60Hz	18.8/9.4	40	1342	148/67
VFT65	10.0	230/460V	3Φ	60Hz	30/15	33	2189	196/89
VFT71	15.0	230/460V	3Φ	60Hz	42/21	42	2824	419/190
VFT72	25.0	230/460V	3Φ	60Hz	54/27	55	3178	507/230
VFT73	30.0	230/460V	3Φ	60Hz	72/36	69	3531	550/250