



RING COMPRESSORS

OPERATION AND PARTS MANUAL

[0TH SERIES & 4TH SERIES]

Thank you for purchasing our Ring Compressor. Our product is produced with high quality materials and manufacturing processes. Our superior workmanship will give you the best product available in the air moving market place. Please read the instructions carefully prior to usage.

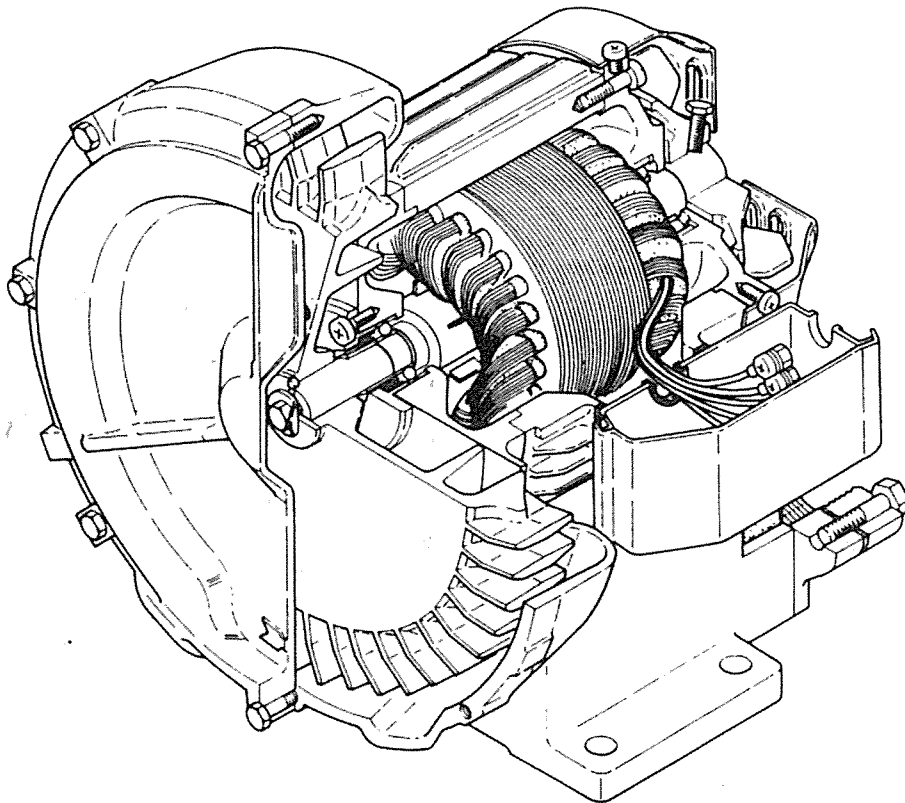

Fuji Electric Corp. of America

Operating instructions

1) Handling gases

The Ring Compressors are used for handling non-combustible, non-corrosive and non-explosive, gases and air. The inlet and ambient air or gas temperature should be less than 104°F (40°C), and the relative humidity not exceed 80%.

2) Installation

The Ring Compressors can be installed in any direction. When installed vertically, the motor side should upward. VFC704A, 804A and VFC904A should be installed horizontally.

Do not install The Ring Compressors on a base which is subject to or creates vibration. The mounting base should be rigid enough to prevent resonance. Use vibration-insulator bases pads if necessary.

The allowable limit of vibration is shown in the figure.

3) Filtration

Air and gases should be filtered before entering the blower by using an intake or inline filter as recommended in The literature or by The distributor or representatives. Care should be taken not to get dirt or particles be sucked into The Ring Compressor.

4) Direction of rotation

The Ring Compressors should be rotated in the "Arrow" direction as noted on the casing. All units rotate in a clockwise direction as viewed from the motor side. You may observe the rotation by looking at the motor fan or shaft direction. The vacuum connection is marked "IN". The pressure connection is marked "OUT" on the flange.

The three phase units can be run in the reverse or counter-clockwise direction by reversing L1 and L3, but performance is reduced.

The single phase units operate in the clockwise direction only.

5) Electrical connection

A qualified electrician should make the connection and knows the local electrical codes. Connections should be made as per the nameplate and operation instruction connecting diagram on page 5.

For all three phase units a magnetic motor starter should be used with thermal overload protection. The VFC400P-5T and VFC504P-2T requires a definite purpose contactor.

Caution: Please consult your local electrical codes, through a certified electrician or electrical contractor.

6) Temperature rise

The temperature of the air passing through The Ring Compressors will rise as shown in the figures below.

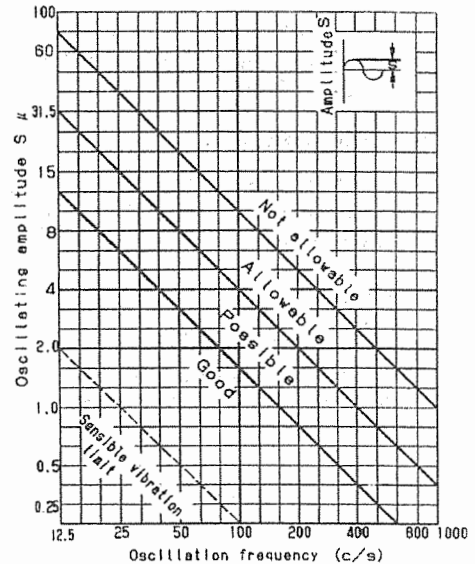
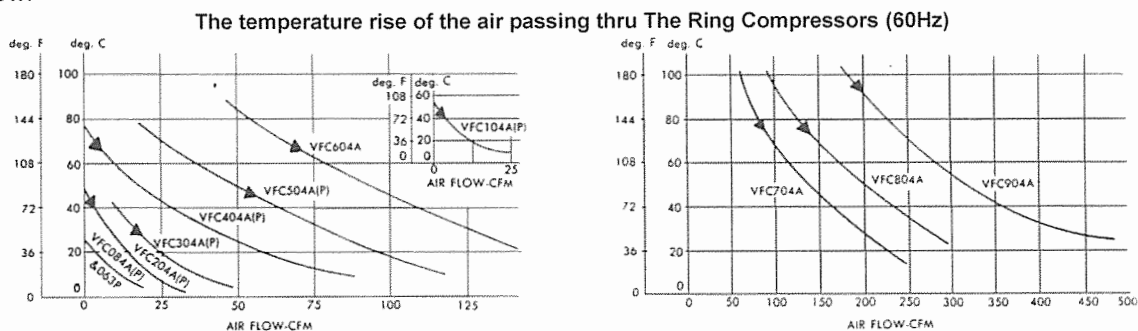

Shut-off allowable time and minimum required airflow for continuous operation

Model	Item	Pressure		Vacuum	
		sec①	CFM②	sec①	CFM②
VFC63P	Cont.	0		Cont.	0
VFC084A,084P	Cont.	0		Cont.	0
VFC104A,104P	600	3.5		600	3.5
VFC204A,204P	240	3.5		240	3.5
VFC304A,304P	120	17		120	16
VFC404A,404P	120	3.5		120	3.2
VFC504A,504P	60	45		60	40
VFC604A	60	56		60	50
VFC704A	30	88		30	70
VFC804A	30	135		30	106
VFC904A	30	195		30	140

- ① Shut-off allowable time(sec)starting at a normal temperature.
- ② Minimum required air flow.
- ③ We suggest that vacuum or pressure relief valves be installed to prevent shut-off conditions on VFC304A/P units and larger.

7) Continuous operations

The Ring Compressors pressure, vacuum and flow can be adjusted from open flow (free air) to shut-off. The minimum flow and maximum shut-off times must be met.

The Ring Compressors must operate within the continuous operating conditions specified in the table.

We recommend our pressure and vacuum relief valves or by-pass hole to prevent shut-off for long periods of time.

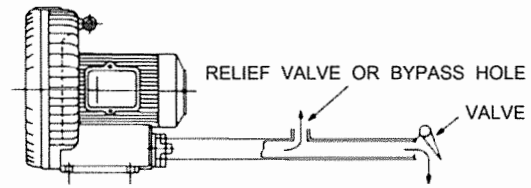

BYPASS (Pressure Use)

8) Maintenance

Clean the inside and outside (particularly the air path of cooling fan) of The Ring Compressors remove dirt and dust. This may result in abnormal temperature rise, loss of performance or increase of vibration.

9) Parts

The bearings, oil-seal and silencer are subject to wear. These parts should be replaced with new ones as necessary. The impeller, casing, gasket and wire net may also need replacement depending on the operating conditions.

**VFC084A, VFC100A thru VFC600A,
VFC063P thru VFC400P and 504P assembly diagram**

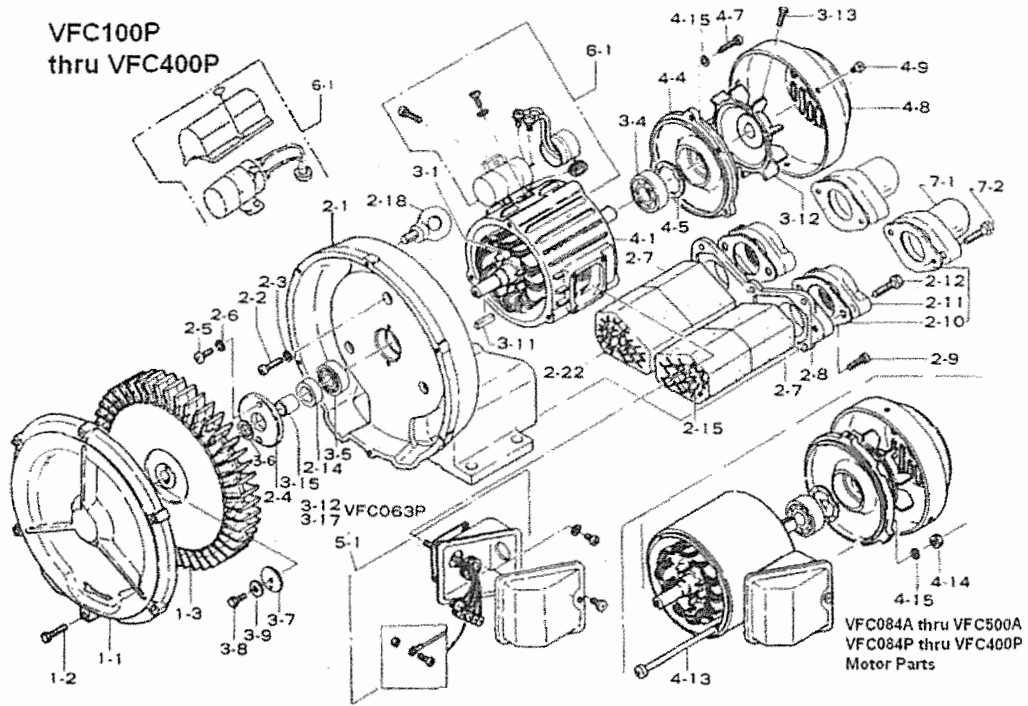

VFC704A thru VFC904A assembly diagram

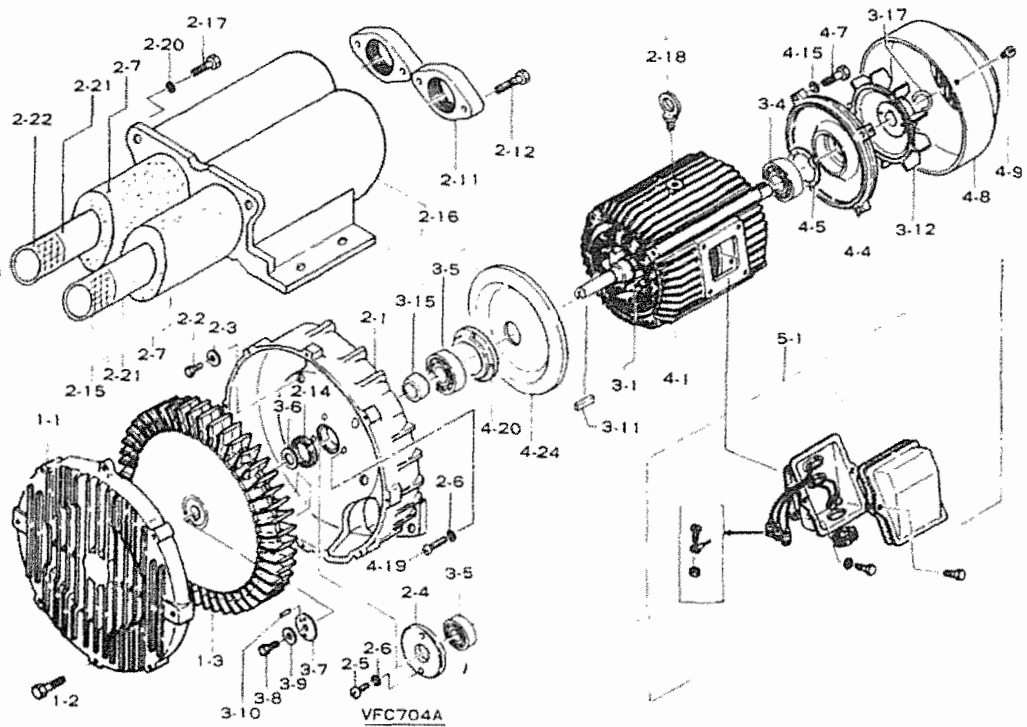

Parts list

When ordering, specify Model No. Serial NO., Name of part, Part No., and Quantity.
Right column shows number of required parts in each unit.

FIG No.	NAME OF PART	VFC 063P	VFC 084P	VFC 100P	VFC 200P	VFC 300P	VFC 400P	VFC 504P	VFC 084A	VFC 100A	VFC 200A	VFC 300A	VFC 400A	VFC 500A	VFC 600A	VFC 704A	VFC 804A	VFC 904A																		
		PART No																																		
1-1	Casing Cover	06P101	1	08P101	1	1S101	1	2S101	1	3S101	1	4Q101	1	5B101	1	08P101	1	1S101	1	2S101	1	3S101	1	4Q101	1	5B101	1	6B101	1	7C101	1	8C101	1	9C101	1	
1-2	Bolt-Casing Cover	06P102	5	4P409	6	4Q409	6	1Q504	6	1Q504	6	4Q102	8	5A102	8	4P409	6	4Q409	6	1Q504	6	1Q504	6	4Q102	8	5A102	8	5A102	8	7A102	7	7A102	7	9A102	7	
1-3	Impeller	06P103	1	08P103	1	1Q103	1	2R103	1	3R103	1	4Q103	1	5C103	1	08P103	1	1Q103	1	2R103	1	3R103	1	4Q103	1	5C103	1	6C103	1	7C103	1	8C103	1	9C103	1	
2-1	Casing	06P201	1	08P201	1	1S201	1	2R201	1	3R201	1	4B201	1	5S201	1	08P201	1	1S201	1	2R201	1	3R201	1	4B201	1	5C201	1	6D201	1	7C201	1	8C201	1	9C201	1	
2-2	Bolt-Casing	06P202	3	N/A	N/A	N/A	N/A	N/A	N/A	N/A	N/A	N/A	N/A	N/A	N/A	N/A	N/A	N/A	N/A	N/A	N/A	N/A	N/A	N/A	N/A	N/A	N/A	N/A	N/A	N/A	N/A	N/A	N/A	N/A		
2-3	Spring Washer	N/A	N/A	N/A	N/A	N/A	N/A	N/A	N/A	N/A	N/A	N/A	N/A	N/A	N/A	N/A	N/A	N/A	N/A	N/A	N/A	N/A	N/A	N/A	N/A	N/A	N/A	N/A	N/A	N/A	N/A	N/A	N/A			
2-4	End Cover	N/A	1P204	1	1Q204	1	2Q204	1	2Q204	1	4Q204	1	5C204	1	1P204	1	1Q204	1	2Q204	1	2Q204	1	4Q204	1	5C204	1	5C204	1	7A204	1	N/A	N/A	N/A	N/A		
2-5	Bolt-End Cover	N/A	1P205	2	2P205	2	2P205	2	2P205	2	4Q205	2	4P202	2	1P205	2	2P205	2	2P205	2	2P205	2	4Q205	2	4P202	2	4P202	2	4P202	2	4P202	2	N/A	N/A	N/A	
2-6	Spring Washer	N/A	1P203	2	2P206	2	2P206	2	2P206	2	4P203	2	1P203	1	2P206	2	2P206	2	2P206	2	2P206	2	4P203	2	4P203	2	4P203	2	4P203	2	4P203	2	4P203	2	4P203	2
2-7	Silencer Assembly (Suc. & Del.)	06P207	1	1Q207	1	1Q207	1	2Q207	1	3Q207	1	4Q207	1	5B207	1	1Q207	1	1Q207	1	2Q207	1	3Q207	1	4Q207	1	5B207	1	6B207	1	7C207	1	8C207	1	9C207	1	
2-8	Flange	06P208	1	08P208	1	1Q208	1	2Q208	1	3Q208	1	4Q208	1	5C208	1	08P208	1	1Q208	1	2R208	1	3Q208	1	4Q208	1	5C208	1	6B208	1	N/A	N/A	N/A	N/A	N/A	N/A	
2-9	Bolt-Flange	06P202	1	4R209	6	4Q205	6	2P205	5	2P205	6	4Q209	6	5C209	6	4R209	6	4Q205	6	2Q209	5	2P205	6	4Q209	6	5C209	6	2P205	6	N/A	N/A	N/A	N/A	N/A		
2-10	Gasket-Flange	N/A	N/A	1P210	2	1P210	2	3P211	2	4P211	2	N/A	N/A	1P210	2	1P210	2	3P211	2	4P211	2	4P211	2	4P211	2	4P211	2	4P211	2	4P211	2	4P211	2	4P211	2	
2-11	Threaded Flange	N/A	N/A	1P211	2	1P211	2	3P211	2	4P211	2	N/A	N/A	1P211	2	1P211	2	3P211	2	4P211	2	4P211	2	4P211	2	4P211	2	4P211	2	4P211	2	4P211	2	4P211	2	
2-12	Bolt-Threaded Flange	N/A	N/A	1Q212	4	1Q212	4	3Q212	4	7A407	4	7A407	4	N/A	N/A	1Q212	4	1Q212	4	3Q212	4	7A407	4	7A407	4	7A407	4	6B212	4	6B212	4	9A422	4	9C212	4	
2-14	Shaft Seal	N/A	N/A	1R214	1	2P214	1	2P214	1	4P214	1	5C214	1	N/A	N/A	1R214	1	2P214	1	2P214	1	4P214	1	5C214	1	5C214	1	7A214	1	8A214	1	9A214	1	N/A	N/A	
2-15	Silencer Retaining Net (Suc.)	N/A	N/A	N/A	N/A	N/A	N/A	N/A	N/A	4R215	1	5B215	1	N/A	N/A	N/A	N/A	N/A	N/A	N/A	N/A	N/A	N/A	N/A	N/A	N/A	N/A	N/A	N/A	N/A	N/A	N/A	N/A			
2-16	Silencer Box	N/A	N/A	N/A	N/A	N/A	N/A	N/A	N/A	N/A	N/A	N/A	N/A	N/A	N/A	N/A	N/A	N/A	N/A	N/A	N/A	N/A	N/A	N/A	N/A	N/A	N/A	N/A	N/A	N/A	N/A	N/A	N/A			
2-17	Bolt-Silencer Box	N/A	N/A	N/A	N/A	N/A	N/A	N/A	N/A	N/A	N/A	N/A	N/A	N/A	N/A	N/A	N/A	N/A	N/A	N/A	N/A	N/A	N/A	N/A	N/A	N/A	N/A	N/A	N/A	N/A	N/A	N/A	N/A			
2-18	Lifting Bolt	N/A	N/A	N/A	N/A	N/A	N/A	N/A	N/A	5A218	1	N/A	N/A	N/A	N/A	N/A	N/A	N/A	N/A	N/A	N/A	N/A	N/A	N/A	N/A	N/A	N/A	N/A	N/A	N/A	N/A	N/A	N/A	N/A		
2-20	Washer-Silencer Box	N/A	N/A	N/A	N/A	N/A	N/A	N/A	N/A	N/A	N/A	N/A	N/A	N/A	N/A	N/A	N/A	N/A	N/A	N/A	N/A	N/A	N/A	N/A	N/A	N/A	N/A	N/A	N/A	N/A	N/A	N/A	N/A	N/A		
2-21	Silencer Retaining Sheath (Suc. & Del.)	N/A	N/A	N/A	N/A	N/A	N/A	N/A	N/A	N/A	N/A	N/A	N/A	N/A	N/A	N/A	N/A	N/A	N/A	N/A	N/A	N/A	N/A	N/A	N/A	N/A	N/A	N/A	N/A	N/A	N/A	N/A	N/A	N/A		
2-22	Silencer Retaining Net (Del.)	N/A	N/A	N/A	N/A	N/A	N/A	N/A	N/A	4R222	1	5B222	1	N/A	N/A	N/A	N/A	N/A	N/A	N/A	N/A	N/A	N/A	N/A	N/A	N/A	N/A	N/A	N/A	N/A	N/A	N/A	N/A	N/A		
3-1	Rotor and Shaft Assembly	06P301	1	08P301	1	1S301	1	2S301	1	3S301	1	4S301	1	5S301	1	08A301	1	1B301	1	2C301	1	3C301	1	4E301	1	5E301	1	6E301	1	7D301	1	8D301	1	9D301	1	
3-4	Bearing-Rear	06P304	1	1P304	1	2P304	1	2P304	1	2P304	1	4P304	1	5A305	1	1P304	1	2P304	1	2P304	1	2P304	1	4P304	1	5A305	1	5A305	1	7A304	1	8A304	1	8A305	1	
3-5	Bearing-Front	06P304	1	1P304	1	2P304	1	2P304	1	2P304	1	4P304	1	5D305	1	1P304	1	2P304	1	2P304	1	2P304	1	4P304	1	5D305	1	5D305	1	7D305	1	8D305	1	8D305	1	
3-6	Bearing-Shim	06P306	1	1P306	1	1P306	1	2P305	1	2P306	1	2P305	1	5C306	1	1P306	1	1P306	1	2P306	1	2P306	1	2P306	1	5C306	1	6C306	1	7A306	1	8A306	1	9A306	1	
3-7	Plate Retaining	06P307	1	1Q307	1	1Q307	1	2Q307	1	2Q307	1	4Q307	1	5B307	1	1Q307	1	1Q307	1	2Q307	1	2Q307	1	4Q307	1	5B307	1	6A307	1	6A307	1	8A307	1	8A307	1	
3-8	Bolt-impeller	06P308	1	1P308	1	1P308	1	2P308	1	2P308	1	4P308	1	4P308	1	1P308	1	1P308	1	2P308	1	2P308	1	4P308	1	4P308	1	6A308	1	6A308	1	8A308	1	8A308	1	
3-9	Tab-Washer	4P203	1	1P309	1	1P309	1	2P309	1	2P309	1	4P309	1	1P309	1	1P309	1	1P309	1	2P309	1	2P309	1	4P309	1	4P309	1	6A309	1	6A309	1	8A309	1	8A309	1	
3-10	Pin	N/A	N/A	N/A	N/A	N/A	N/A	N/A	N/A	N/A	N/A	N/A	N/A	N/A	N/A	N/A	N/A	N/A	N/A	N/A	N/A	N/A	N/A	N/A	N/A	N/A	N/A	N/A	N/A	N/A	N/A	N/A	N/A			
3-11	Key-Impeller	N/A	08P311	1	1P311	1	2P311	1	2P311	1	4P311	1	5B311	1	08P311	1	1P311	1	2P311	1	2P311	1	4P311	1	5B311	1	6A311	1	7A311	1	8A311	1	9A311	1		
3-12	Motor Fan	06P312	1	08P312	1	N/A	2S312	1	2S312	1	4S312	1	6D312	1	08P312	1	N/A	2S312	1	2S312	1	4S312	1	5D312	1	6D312	1	7D312	1	8D312	1	9D312	1	N/A	N/A	
3-13	Bolt-Motor Fan	N/A	08P313	1	N/A	2S313	1	2S313	1	4S313	1	2S313	1	08P313	1	N/A	2S313	1	2S313	1	4S313	1	5D313	1	6D313	1	7D313	1	8D313	1	9D313	1	N/A	N/A		
3-15	Collar	N/A	N/A	2P315	1	2P315	1	2P315	1	4P315	N/A	N/A	N/A	1P315	1	2P315	1	2P315	1	4P315	1	N/A	N/A	N/A	N/A	N/A	N/A	N/A	N/A	N/A	N/A	N/A	N/A	N/A		
3-17	Retaining Rings-C Type	06P317	1	N/A	N/A	N/A	N/A	N/A	N/A	N/A	N/A	N/A	N/A	N/A	N/A	N/A	N/A	N/A	N/A	N/A	N/A	N/A	N/A	N/A	N/A	N/A	N/A	N/A	N/A	N/A	N/A	N/A	N/A			
4-1	Frame Stator and Protector Assy.	High voltage 06P4012 Low voltage 06P4011	1	08S401	1	1T401	1	2T401	1	3S401	1	4S401	1	5S401	1	08A4014 08A4012	1	1E401	1	2E401	1	3D401	1	4E401	1	5E401	1	6E401	1	7D401	1	8D401	1	9D401	1	
4-4	Rear Housing	06P404	1	08P404	1	1T404	1	2P404	1	2P404	1	4D404	1	6D404	1	08P404	1	1T404	1	2P404	1	2P404	1	4D404	1	5D404	1	6D404	1	7C404	1	8C404	1	9C404	1	
4-5	Spring Washer	06P405	1	08P405	1	2P405	1	2P405	1	2P405	1	4P405	1	5C405	1	08P405	1	2P405	1	2P405	1	2P405	1	4P405	1	5C405	1	5C405	1	7A405						

Trouble shooting -----

	Troubles	Possible cause (* 3 Phase Units, **1 Phase Units)	Remedy
Impeller does not turn	Humming sound	1. One phase of line not connected. (*) 2. One phase of stator winding open (*) 3. Bearings defective 4. Impeller jammed by foreign material 5. Impeller jammed against housing or cover 6. Capacitor open (**)	1. Connect 2. Contact Factory 3. Change bearings 4. Clean 5. Adjust 6. Change capacitor
	No sound	1. Two phases of power line not connected. (*) 2. Two phases of stator winding open (*)	1. Connect 2. Contact factory
Impeller turn	Blown fuse	1. Insufficient fuse capacity 2. Short circuit	1. Use fuse or proper rating 2. Repair
	Motor overheated or protector trips	1. High or low voltage 2. Operating in single phase condition (*) 3. Bearing defective 4. Impeller rubbing against housing or cover 5. Impeller or air passage clogged by foreign material 6. Unit operating beyond performance range 7. Capacitor shorted 8. One phase of stator winding short circuited (*)	1. Check input voltage 2. Check connections 3. Change bearings 4. Adjust 5. Clean 6. Contact factory 7. Change capacitor 8. Contact factory
	Abnormal sound	1. Impeller rubbing against housing or cover 2. Impeller or air passages clogged by foreign material 3. Bearings defective	1. Adjust 2. Clean 3. Change bearings
	Performance below standard	1. Leak in piping 2. Piping and air passages clogged 3. Impeller rotation reversed 4. Leak in Compressor 5. Low voltage	1. Tighten 2. Clean 3. Check wiring 4. Tighten cover, flange 5. Check input voltage

Connections -----

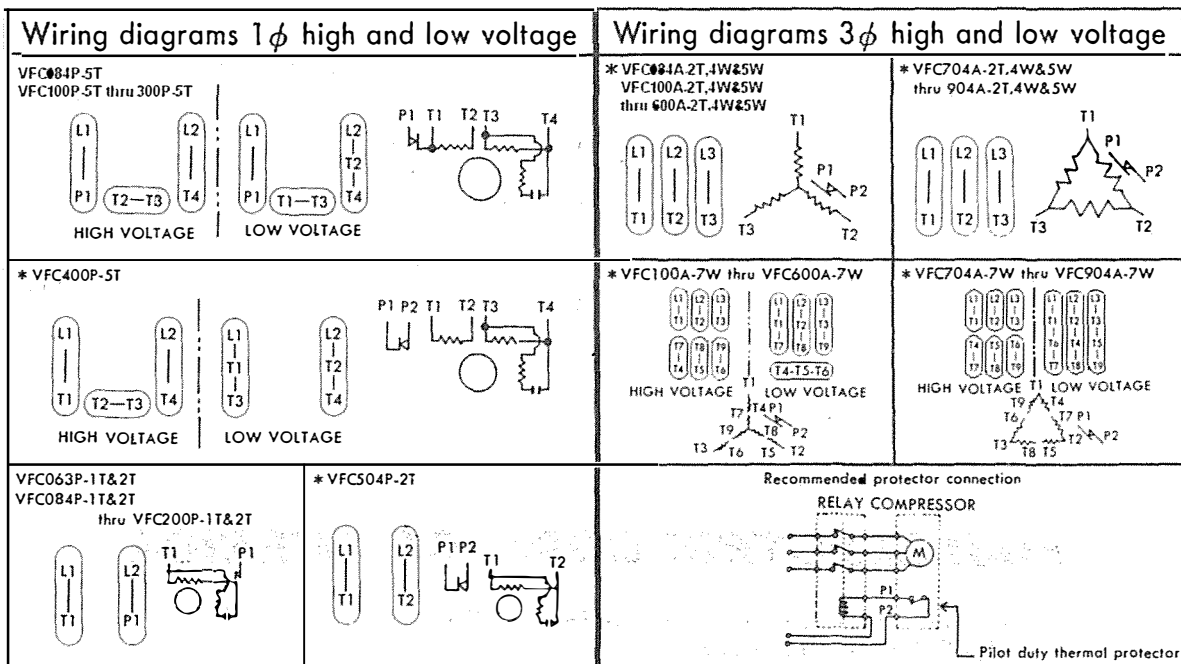

- (Note)
1. The marking * : Pilot duty thermal protector.
 2. Model VFC504A-2T may not be equipped with thermal protector. Please check it on the nameplate.
 3. All 3-phase units use magnetic starter.



WARNING!

This blower is designed to operate indoors, and is an environment that is a water-free and dust-free.

This blower is only a component, it must be installed in a machine or part of a machinery which meets the terms of the Machine directive 89/392/EEC. Commission will not occur until the end product or machinery conforms with the guidelines in EN60204-1.

FUJI ELECTRIC CORP. OF AMERICA

50 Northfield Avenue, Edison, NJ 08837
TELEPHONE : 510-440-1060 FAX : (201)368-8258