

## Features

- ① Special resins are used in the pump to enhance reliability
- ② New mechanical seal-less structure
- ③ High total head models added to the Series
- ④ EU RoHS Directive  
(Restriction of Use of Six Hazardous Substances)compliant



## Structure

Non-seal (mechanical seal-less) structure. Cast iron and special resin with high reliability are used in the pump's main unit.

## How to read the model type

**VKR 14 5 A** □

①      ②      ③      ④      ⑤

- ① Model
- ② Output code(ex. 14: 2.2kW)
- ③ Model
- ④ Number of phases(3-phase)
- ⑤ Number of impellers(B: 2; C: 3; D: 4; E: 5; F: 6 blades)



## Selection chart

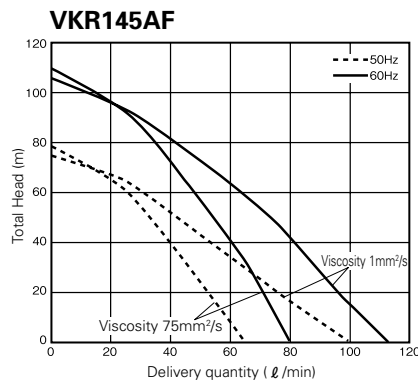
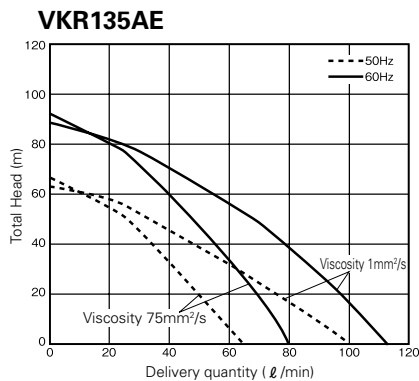
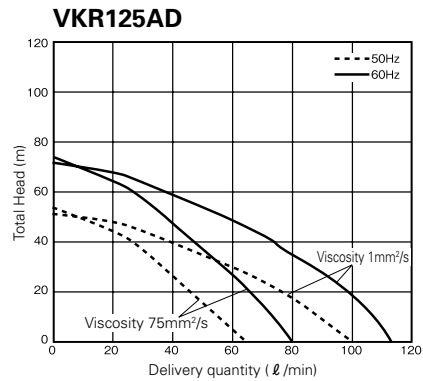
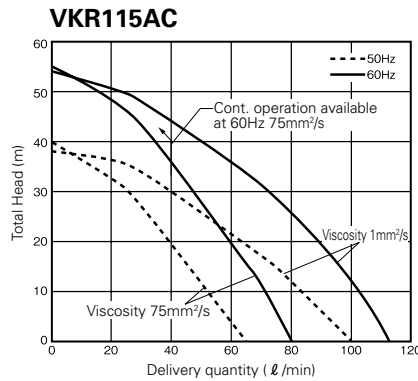
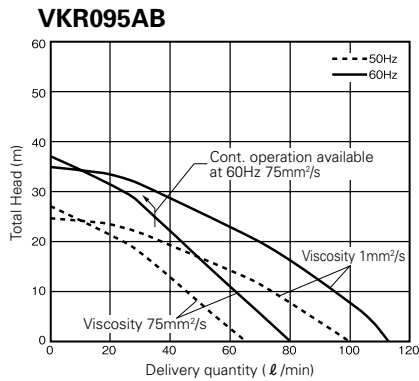

Note: The delivery quantity varies according to the type of liquid circulated and the liquid's viscosity.

## Specifications

Specifications	Type	VKR095AB		VKR115AC		VKR125AD		VKR135AE		VKR145AF	
Output (kW)		0.4		0.75		1.1		1.5		2.2	
Rated voltage (V)		200	200/220	200	200/220	200	200/220	200	200/220	200	200/220
Frequency (Hz)		50	60	50	60	50	60	50	60	50	60
Rated current (A)		3	3/3	4.4	4.5/4.5	6	5.9/5.4	7	8.2/8.5	7.6	10.1/9.6
Delivery quantity (l/min)		20	20	30	30	30	30	30	30	30	30
Total head (m)		22	33	30	43	45	65	52	77	60	90
Max. viscosity (mm²/s)		75	75*	75	75*	75	75	75	75	75	75
Inlet/outlet (PS)		3/4		3/4		3/4		3/4		3/4	
Finish paint		Munsell N1									
Standard		IEC60034-1 CE approved									
Degree of protection		IP54									

Notes 1. Delivery quantity and total head values were obtained in tests with a liquid viscosity of 1mm<sup>2</sup>/s (same as tap water at normal temperature). Note that the pumps cannot be used with water.  
2. ★mark: For kinematic viscosity 75mm<sup>2</sup>/s, the VKR095AB can be used at 35l/min (3A) or less. The VKR115AC can be used at 40l/min (4.5A) or less.

## Assembly Drawing

Fig.1

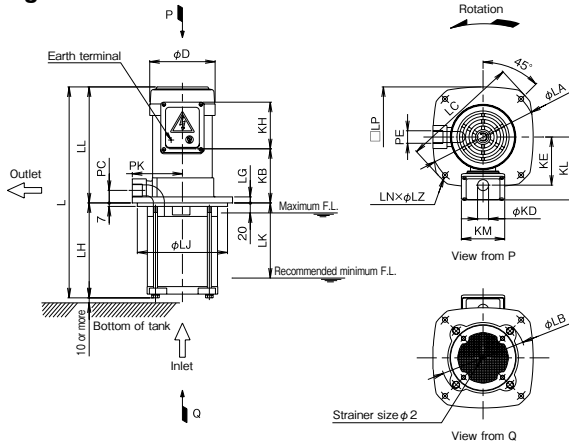

Fig.2

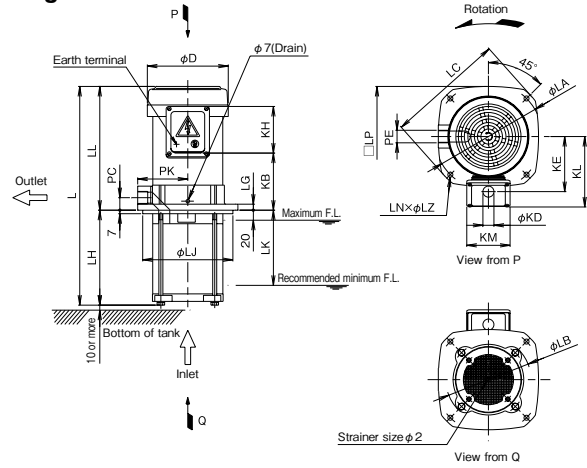
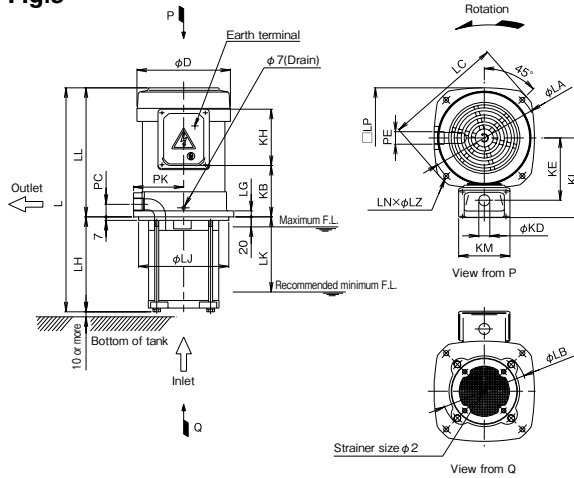

Fig.3



## Dimensions

(Unit: mm)

Type	Fig.	D	KB	KD	KE	KH	KL	KM	L	LA	LB	LC	LG	LH	LJ	LK	LL	LN	LP	LZ	PC	PE	PK	Mass (kg)
VKR095AB	1	131	107	22	96	94	126	87	421	215	170	235	12	190	180 <sup>0</sup> <sub>-0.7</sub>	150	231	4	200	10	25	Rp3/4	100	18.0
VKR115AC	2	162	113	22	110	94	141	87	437	215	170	235	12	190	180 <sup>0</sup> <sub>-0.7</sub>	150	247	4	200	10	25	Rp3/4	100	22.0
VKR125AD	3	187	103	22	124	112	159	102	447	215	170	235	12	190	180 <sup>0</sup> <sub>-0.7</sub>	150	257	4	200	10	25	Rp3/4	100	26.0
VKR135AE	3	187	143	22	124	112	159	102	547	215	170	235	12	250	180 <sup>0</sup> <sub>-0.7</sub>	210	297	4	200	10	25	Rp3/4	100	32.0
VKR145AF	3	187	143	22	124	112	159	102	547	215	170	235	12	250	180 <sup>0</sup> <sub>-0.7</sub>	210	297	4	200	10	25	Rp3/4	100	32.0

## Sectional drawing

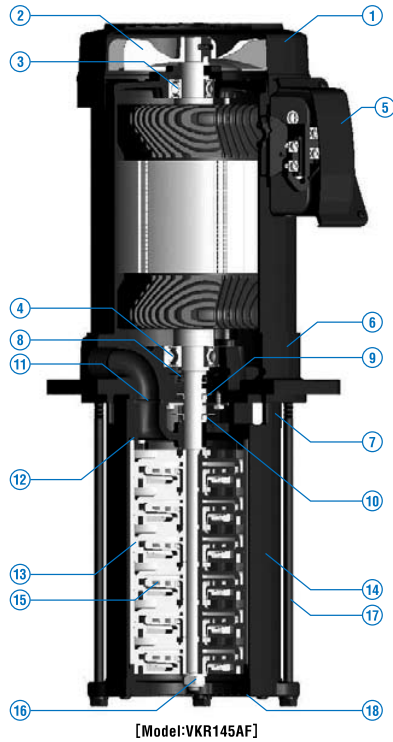

No.	Parts Name	Materials
1	Fan cover	SPCC
2	External fan	Resins
3	Deep groove ball bearing	
4	AC bearing	
5	Terminal box	SPCC
6	Pump leg	FC150
7	Pump leg	FC150
8	Oil seal	NBR
9	Oil thrower	SPC/plated
10	Oil thrower	SPC/plated
11	O-ring	NBR
12	O-ring	NBR
13	Casing	Resins
14	Outer casing	SPHC
15	Impeller	Resins
16	U-nut	SS/plated
17	Fastening bolt	SS/plated
18	Strainer	SUS304

Note: Structure and other details are subject to change without notice.