

Non-Bypass Panels

FRENIC-EcoPAK

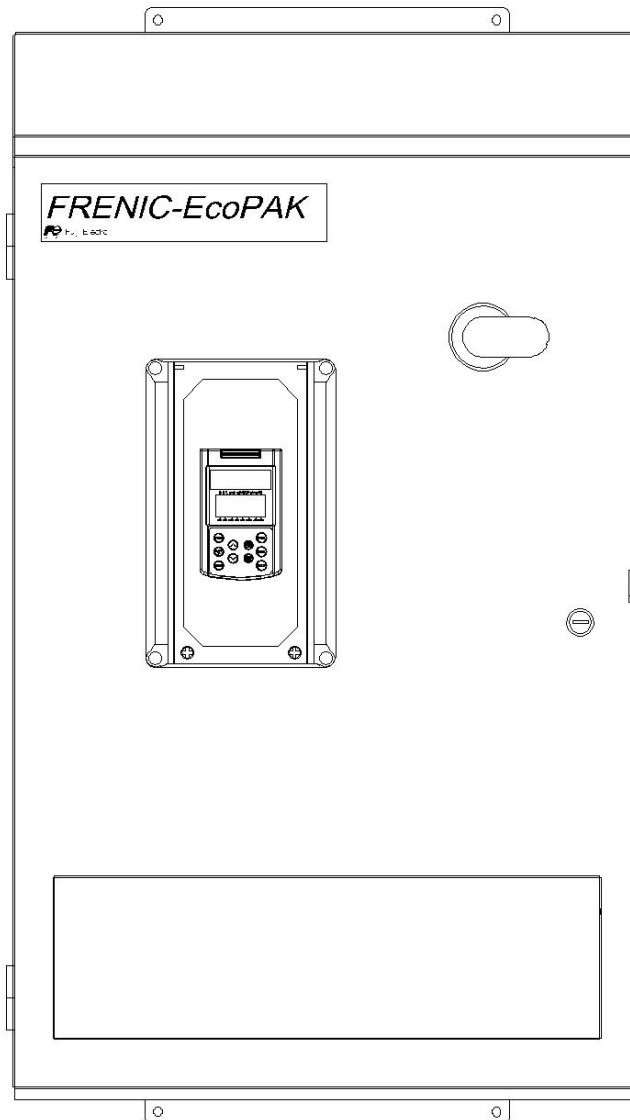

Safety Precautions

Read this manual thoroughly before proceeding with installation, connections (wiring), or maintenance and inspection. Ensure you have sound knowledge of the device and familiarize yourself with all safety information and precautions before proceeding to operate the drive. Refer to the **FRENIC-Eco** drive instruction manual (INR-SI47-1225-E) for further safety information.

Safety precautions are classified into the following two categories in this manual.



Failure to heed the information indicated by this symbol may lead to dangerous conditions, possibly resulting in death or serious bodily injuries.



Failure to heed the information indicated by this symbol may lead to dangerous conditions, possibly resulting in minor or light bodily injuries and/or substantial property damage.

***FRENIC-EcoPAK* Non-Bypass Panel Overview**

The ***FRENIC-EcoPAK*** non-bypass panel is a packaged drive solution in a Type 3R enclosure.

Features

- Type 3R enclosure
- Metallic enclosures to reduce radio frequency interference (RFI)
- Integral main disconnect with branch circuit protection, including a padlockable through-the-door operator handle mechanically interlocked with the enclosure door
- 3% AC line reactor provided as standard below 100HP to minimize harmonics and provide transient voltage protection for the drive, with the option of a 5% AC line reactor. At 100HP and above, a DC link reactor is provided, with the option for adding a 3% or 5% AC line reactor
- Control power transformer with primary & secondary fusing
- Door mounted drive keypad with backlit LCD and LED displays for drive set-up, troubleshooting, local operation control, maintenance indication, and operational indication
- Damper Control Output Contacts
- Built-in communications, user selectable between Modbus RTU, Metasys[®] N2, or APOGEE[®] FLN (P1), with additional communication options including: LONWORKS[®], BACnet, DeviceNet, and Profibus DP
- UL/cUL Listed

APOGEE is a registered trademark of Siemens Building Technologies, Inc.
LONWORKS is a registered trademark of Echelon Corporation.
Metasys is a registered trademark of Johnson Controls, Inc

Panel Identification

Fuji Electric	
Model Nbr:	PNL020F1/1-46U-31BDCX
Serial Nbr:	F08-0000
Input Ratings	
Voltage:	460
Total FLA:	29.0
Phase:	3
Hz:	60
Output Ratings	
Voltage:	0-460
Max / Motor FLA:	28.0
Phase:	3
Hz:	0-120
Short Circuit Current:	5 kA rms symmetrical
	480 V maximum
Enclosure Type:	1
Elementary Drawing:	ROA100010
Outline/Layout Drawing:	ROA300004
Installation Instructions:	INR-S47-1206-E
UL FILE # E105891	

Each **FRENIC-EcoPAK** panel has a nameplate label, like the example pictured above, which contains important information about the panel. This label is located on the inside of the hinged door on the enclosure.

CAUTION

- Refer to the nameplate label to determine the panel input voltage and current requirements prior to installation and wiring.
- Refer to the nameplate label for the correct wiring diagram (Elementary Drawing).
- Sizing of field wiring conductors should be based upon the current ratings listed on the nameplate label.

Installation



The **FRENIC-EcoPAK** panel should be located:

- Away from flammable or combustible liquids, gases, and other materials
- Away from sources of dust, metal shavings, or other particulate material
- Away from corrosive liquids, spray, or mist
- Away from sources of heat
- Where the ambient temperature will remain between -10°C (14°F) and 40°C (104°F)

Wall-mount panels must be mounted on a non-flammable heat-resistant surface that is capable of supporting the weight of the panel.

Refer to the dimensional drawing that shipped with the panel for required clearances.

Routing of field wiring should be planned in coordination with choosing a mounting location.

Wiring Overview

The **FRENIC-EcoPAK** panel must be connected to an input power source, a motor (output power), and control signals.

WARNING

- Wiring should be performed by a qualified electrician using standard practices as specified by local and national codes.
- Always make sure the input power source is OFF before connecting or disconnecting any power input, output, or control wiring.
- Ground the panel, as specified by local and national codes, using the provided grounding lugs or bus bar.
- Make sure that the input power source (phases, voltage, and current capacity) matches the requirements of the panel as stated on the nameplate.
- Never connect line voltage to the drive output terminals (U, V, and W).
- When making holes for conduit fittings, be sure to cover the drive and other components to protect them from metal shavings.
- Conduit fittings must maintain 3R rating.

CAUTION

- All field wiring should be copper with a minimum insulation rating of 75°C.
- Sizing of field wiring conductors should be based upon the current ratings listed on the nameplate label, in accordance with local and national codes.

Refer to the wiring diagram that shipped with this panel and the torque table in this instruction manual.

Refer to the diagrams on the following pages for general component layout and for general routing of power input, power output (motor connections), and control wiring for your panel. Power input wiring should be routed away from power output wiring, and both should enter the panel from separate conduit. Control wiring should be routed away from power wiring, and should enter the panel from separate conduit. All panels require holes to be drilled in the field.

Refer to the following section **Control Wiring** for descriptions of the control connections.

Wiring Overview (cont'd)

2-5Hp @ 208V
2-7.5Hp @ 460V

7.5-15Hp @ 208V
10-20Hp @ 460V

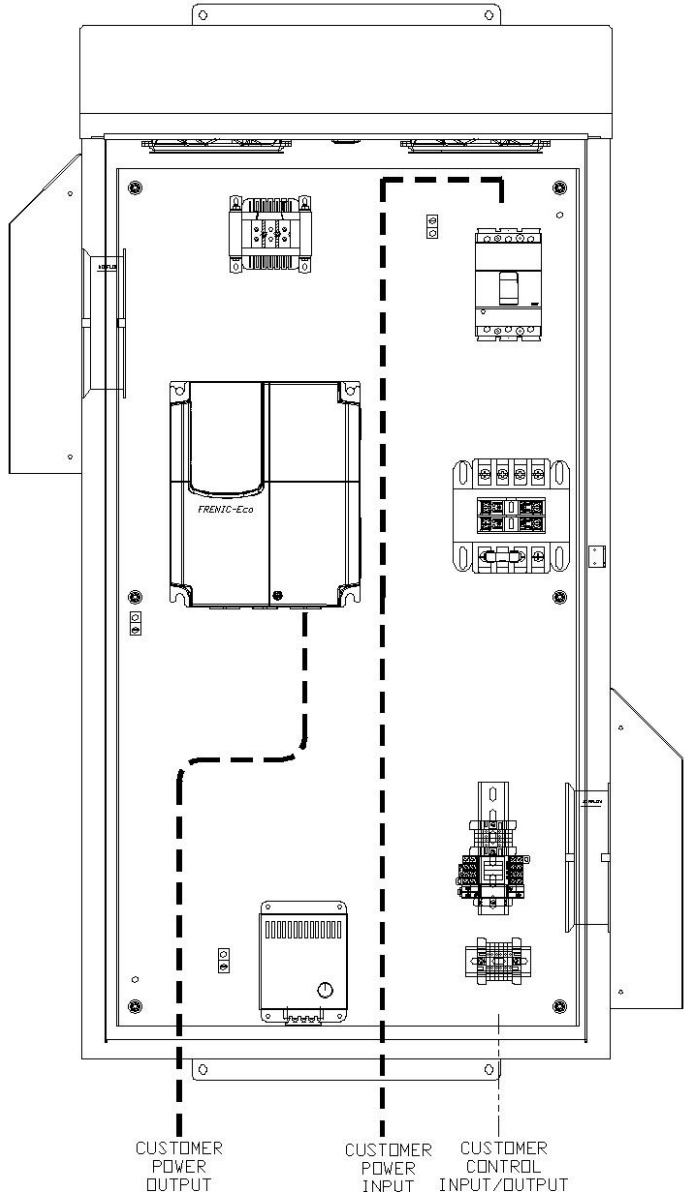
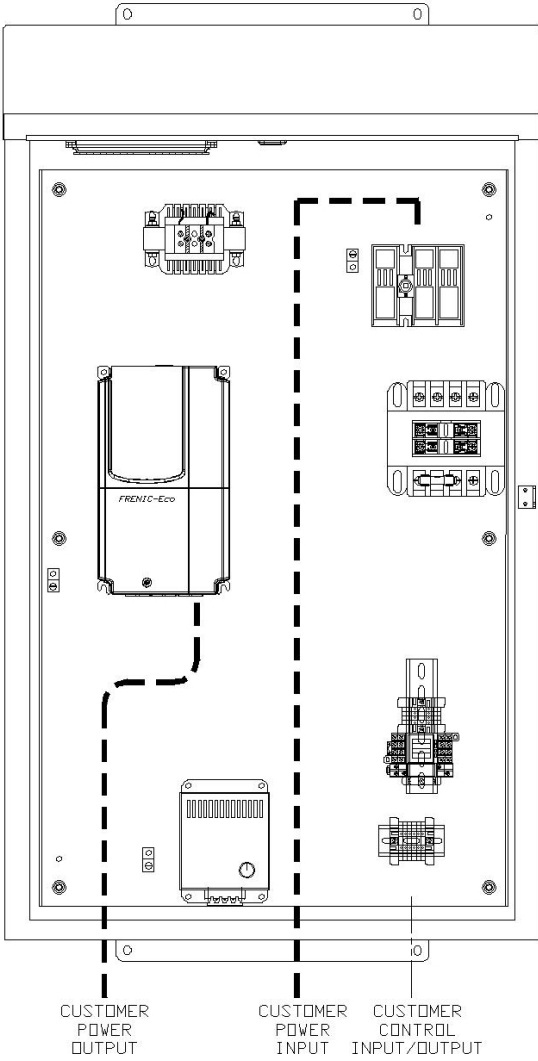

Wiring Overview (cont'd)

20-25Hp @ 208V
25-40Hp @ 460V

30Hp @ 208V
50-75Hp @ 460V

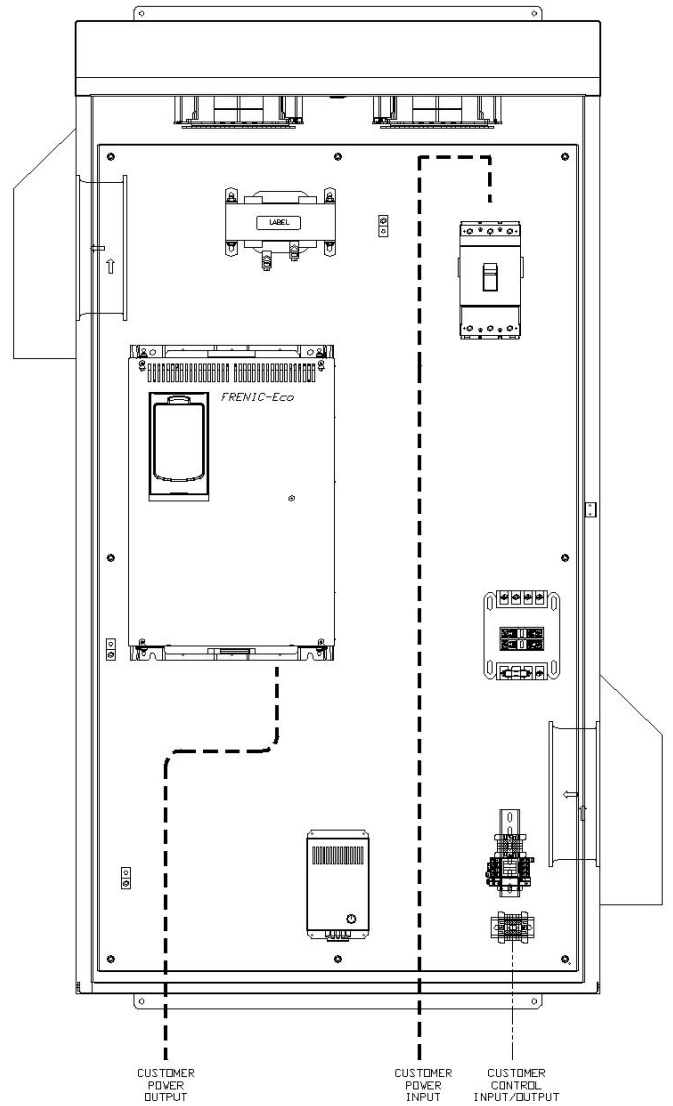
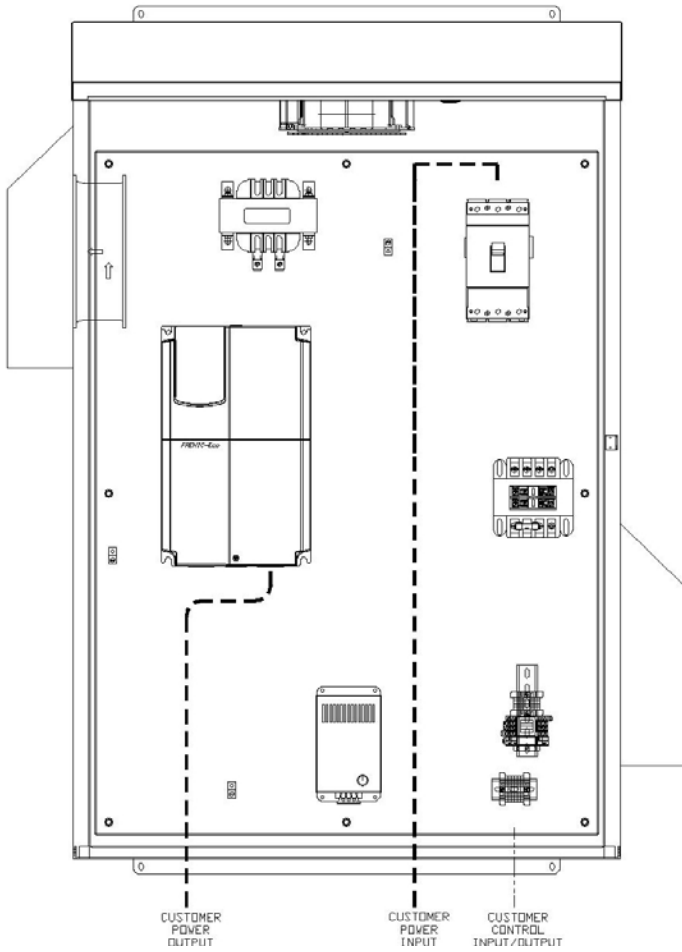

Control Wiring

All control wiring, except the damper control output and the programmable relay outputs, connects to the terminals on the drive. The following diagram shows control connections that are available on **FRENIC-EcoPAK** panels:

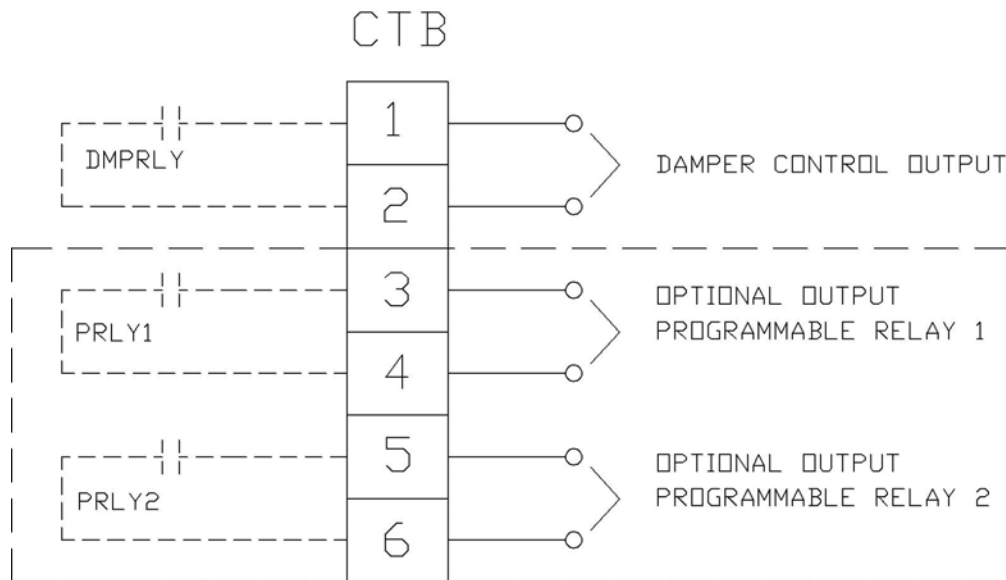

Description of Control Connections

- **Damper Control output (DMPRLY):**
 - CTB 1-2
 - Used to control the position of a damper valve in coordination with drive operation
- **Programmable Relay 1 output (PRLY1):**
 - CTB 3-4 for NO contacts rated for 1A @ 230VAC
 - Provides drive output signal Y2, which is user-selectable
- **Programmable Relay 2 output (PRLY2):**
 - CTB 5-6 for NO contacts rated for 1A @ 230VAC
 - Provides drive output signal Y3, which is user-selectable

Field Wiring Torque and Wire Size Values for *FRENIC-EcoPAK 208/230V*

HP	Circuit Breaker 'CB'	Fusible Disconnect 'FUSDISC'	Terminal Blocks 'CTB'
2	n/a	17 in.lb. 18-8 AWG	4.5 in.lb. 22-12 AWG
3	n/a	17 in.lb. 18-8 AWG	4.5 in.lb. 22-12 AWG
5	n/a	17 in.lb. 18-8 AWG	4.5 in.lb. 22-12 AWG
7.5	62 in.lb. 14-1 AWG	17 in.lb. 18-8 AWG	4.5 in.lb. 22-12 AWG
10	62 in.lb. 14-1 AWG	30 in.lb. 14-4 AWG	4.5 in.lb. 22-12 AWG
15	62 in.lb. 14-1 AWG	30 in.lb. 14-4 AWG	4.5 in.lb. 22-12 AWG
20	62 in.lb. 14-1 AWG	120 in.lb. 14-2/0 AWG	4.5 in.lb. 22-12 AWG
25	88 in.lb. 14 AWG to 300kcm	120 in.lb. 14-2/0 AWG	4.5 in.lb. 22-12 AWG
30	88 in.lb. 14 AWG to 300kcm	275 in.lb. 4 AWG to 300kcm	4.5 in.lb. 22-12 AWG

Note: Wire ranges provided indicate conductor sizes that the device terminal or lug will accept. Follow local and national codes for proper conductor sizing.

Field Wiring Torque and Wire Size Values for *FRENIC-EcoPAK 460V*

HP	Circuit Breaker 'CB'	Fusible Disconnect 'FUSDISC'	Terminal Blocks 'CTB'
2	n/a	17 in.lb. 18-8 AWG	4.5 in.lb. 22-12 AWG
3	n/a	17 in.lb. 18-8 AWG	4.5 in.lb. 22-12 AWG
5	n/a	17 in.lb. 18-8 AWG	4.5 in.lb. 22-12 AWG
7.5	n/a	17 in.lb. 18-8 AWG	4.5 in.lb. 22-12 AWG
10	n/a	17 in.lb. 18-8 AWG	4.5 in.lb. 22-12 AWG
15	62 in.lb. 14-1 AWG	17 in.lb. 18-8 AWG	4.5 in.lb. 22-12 AWG
20	62 in.lb. 14-1 AWG	30 in.lb. 14-4 AWG	4.5 in.lb. 22-12 AWG
25	62 in.lb. 14-1 AWG	30 in.lb. 14-4 AWG	4.5 in.lb. 22-12 AWG
30	62 in.lb. 14-1 AWG	30 in.lb. 14-4 AWG	4.5 in.lb. 22-12 AWG
40	62 in.lb. 14-1 AWG	120 in.lb. 14-2/0 AWG	4.5 in.lb. 22-12 AWG
50	62 in.lb. 14-1 AWG	120 in.lb. 14-2/0 AWG	4.5 in.lb. 22-12 AWG
60	62 in.lb. 14-1 AWG	120 in.lb. 14-2/0 AWG	4.5 in.lb. 22-12 AWG
75	88 in.lb. 14 AWG to 300kcm	275 in.lb. 4 AWG to 300kcm	4.5 in.lb. 22-12 AWG

Note: Wire ranges provided indicate conductor sizes that the device terminal or lug will accept. Follow local and national codes for proper conductor sizing.

BASIC PANEL STARTUP



- Make sure all power and control wiring is completed before proceeding.
 - As with all electrical equipment installations, insure all safety/wiring instructions have been followed in accordance with this product's manuals and local and national codes.
-
1. Energize panel by turning disconnect switch to the 'ON' position.
 2. Set drive parameters for the connected motor (refer to table below). Set drive speed control to 'Local' by pushing the 'REM/LOC' button on the drive keypad.
 3. Push the 'FWD' button on the keypad to energize the drive. Use the Up/Down keys to change the drive speed as necessary.
 4. Check that the motor rotates in the correct direction. To change, refer to the **Troubleshooting** section in this manual.
 5. Measure and record motor FLA if required. Allow motor to run at full speed for a sufficient time to insure panel-mounted overloads are properly set. Adjust, if necessary.
 6. Push the 'Stop' button on the keypad and allow the motor to come to a complete stop.
 7. De-energize panel.
 8. Record startup data and change any parameters as necessary.

Setting Up Local Control

Also refer to the following section **Programming the FRENIC-Eco Drive** and the **FRENIC-Eco drive instruction manual (INR-SI47-1225-E)** for more information.

The **FRENIC-EcoPAK** panel was intended to be integrated into a building automation system and controlled by remote signals. If these signals are not available, the panel can be set up to be operated locally. Follow these steps to set the panel up for local operation:

1. Set drive function code F01 to 0.
2. Set drive function code F02 to 2.
3. Set drive function code H96 to 3.

The panel can now be operated directly using the drive keypad.

COMMON PARAMETER SETTINGS

Also refer to the **FRENIC-Eco** drive instruction manual (INR-SI47-1225-E) for more information.

Factory-set drive parameters and settings

These parameters and settings are pre-set from the factory for the panel to be operational. If, for some reason, the drive parameters are reinitialized, these parameters must be reset for correct panel operation.

Drive function codes:

- F01 = 3
- F02 = 1
- F05 = 230 (for 230V panels only - default otherwise)
- F11 = nameplate output current
- F16 = 3
- E01 = 1007
- E02 = 1007
- E03 = 1009
- E20 = 55
- E21 = 0
- E22 = 0
- E24 = 0
- H96 = 0

Drive Switches:

- SW1 set to SINK
- SW5 set to V2

Fan Thermostat:

- Set to 90°F

Heater Thermostat (if equipped):

- Set to 70°F

Programming the *FRENIC-Eco* Drive

Also refer to Chapter 3 in the *FRENIC-Eco* drive instruction manual (INR-SI47-1225-E) for more information.

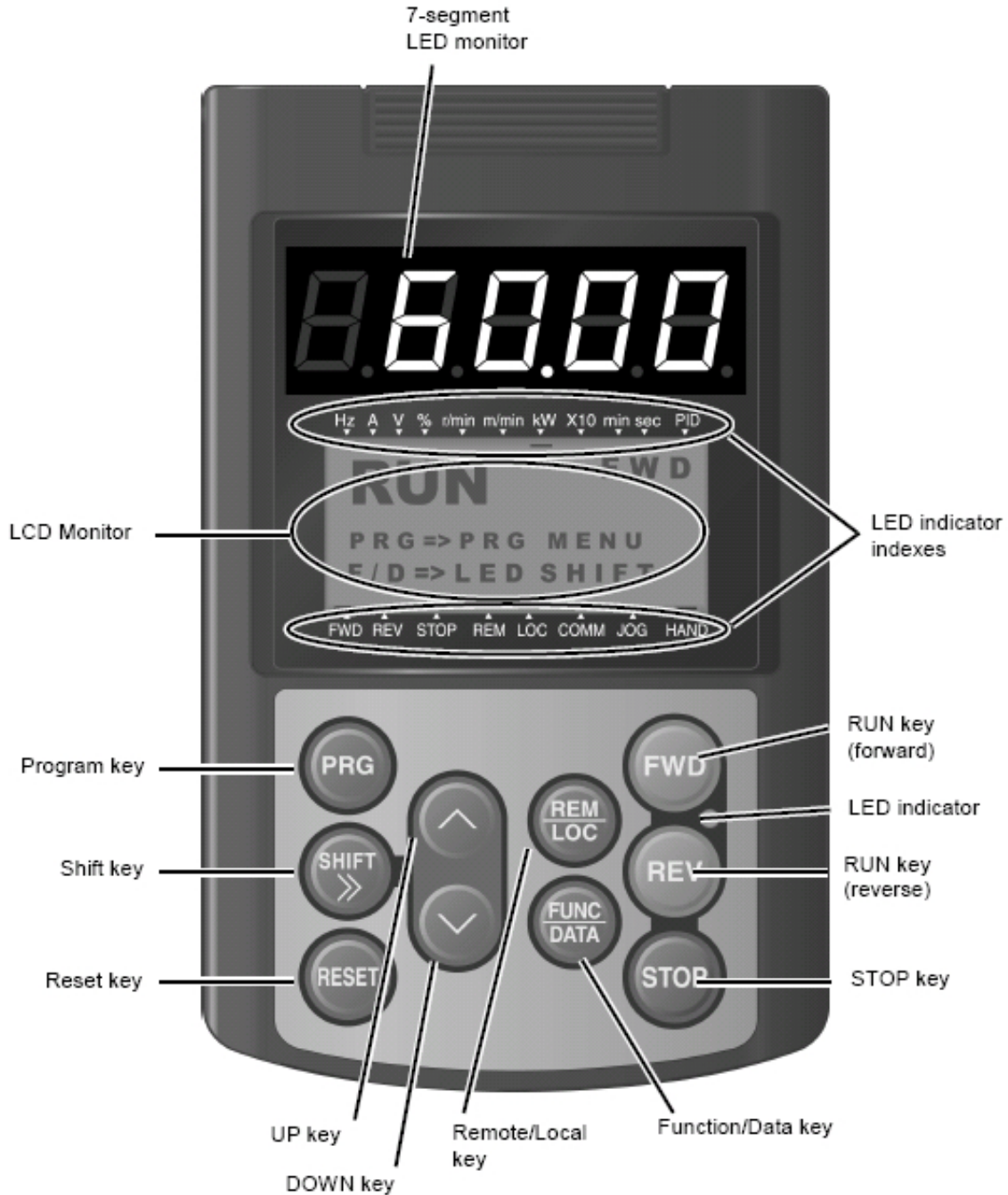

Programming the *FRENIC-Eco* Drive (cont'd)

To set drive parameters using the keypad, first make sure the drive is stopped. Parameters cannot be changed while the drive is running. To enter the programming menu, press the Program Key (PRG) on the keypad. To return to the previous screen, press either (PRG) or (RESET). To select a menu item, use the (UP) and (DOWN) keys on the keypad, then press the (FUNC/DATA) key to go to that screen. Refer to the diagram below for an example of navigating the menu:

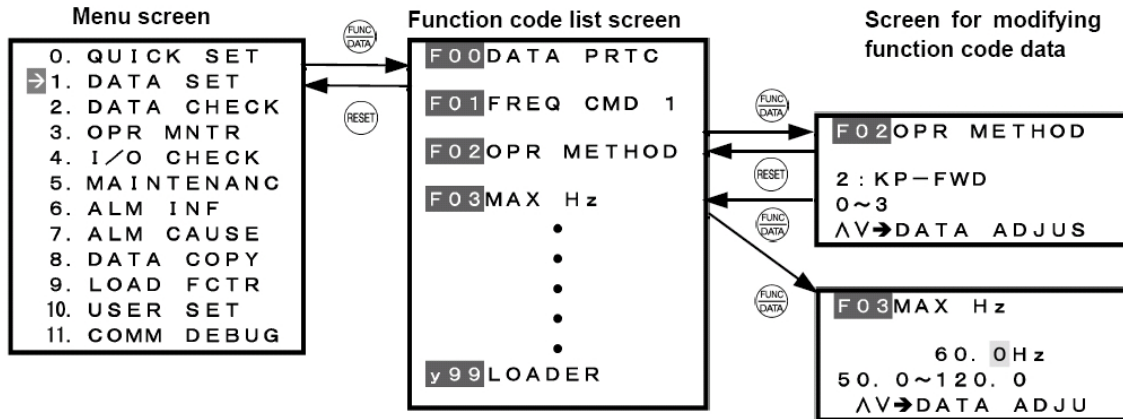

Function code settings can be changed using the (UP) and (DOWN) keys on the keypad. Pressing (FUNC/DATA) saves the changes, while pressing (RESET) discards the changes, and both return to the previous menu.

The most frequently modified parameters can be accessed in the 'Quick-Set' menu (item 0 on the programming menu screen). All parameters can be accessed in the 'Data-Set' menu (item 1 on the programming menu screen).

Recommended user-set drive parameters

These parameters are all in the FRENIC-Eco drive Quick-Start menu for easy access.

- F07 Acceleration Time.
- F08 Deceleration Time.
- F10/F11 Electronic Overload.
- F14 Restart Settings. Refer to drive instruction manual.
- F26 Motor Sound (carrier frequency).
- P02 Motor Capacity (HP).
- P03 Motor FLA.
- P04 Motor Tuning. Refer to drive instruction manual.

OPERATION

Operator Controls

The **FRENIC-EcoPAK** panel includes the following controls for local operation and monitoring:

- Main power disconnect
- Drive keypad

The **FRENIC-EcoPAK** panel includes the following controls for remote operation and monitoring:

- Analog speed reference *input*
- Analog monitor *output*
- Run *input*
- Enable *input*
- Drive Fault *output*
- Drive Run *output*
- Damper control *output*

MAINTENANCE

Periodic Maintenance

The following items require periodic inspection and maintenance:

- Fans should be checked for proper operation and filters checked and/or replaced on a schedule that suits local conditions.
- Power wiring connections should be checked and re-torqued every six months.
- Refer to the **FRENIC-Eco** drive instruction manual (INR-SI47-1225-E) for drive maintenance requirements and schedule.

Fans and Filters

For replacement top exhaust fans (out of warranty period) and expanded aluminum mesh filter media, consult Hoffman at www.hoffmanonline.com with the enclosure catalog number (found on the label on the inside of the hinged door).

For replacement fans (out of warranty period) and filter media, refer to the following tables:

208/230V		Filter		Fan	
HP	Location	Manufacturer	Part Number	Manufacturer	Part Number
2-15	All	Orion	LG172B	Orion	OA172AP-11-1TB
20-30	All	Orion	LG254B	Orion	OA254AN-11-1TBXC

460V		Filter		Fan	
HP	Location	Manufacturer	Part Number	Manufacturer	Part Number
2-20	All	Orion	LG172B	Orion	OA172AP-11-1TB
25-75	All	Orion	LG254B	Orion	OA254AN-11-1TBXC

Replacement fans and filter media can be found at the following sites:

- www.alliedelec.com for Orion fans and filters

Maintenance (cont'd)

Fuses

The **FRENIC-EcoPAK** panel has labels, located on the inside of the hinged door, which list the correct size and type of fuses to be used for that panel. For reference, the following table lists the power fuse sizes (applicable to models with fusible disconnect):

MAIN POWER HP	208/230V Class J	460V Class CC
2	10	6
3	15	8
5	25	12
7.5	30	15
10	45	25
15	60	30
20	80	40
25	100	50
30	125	60
40	n/a	70
50	n/a	90
60	n/a	100
75	n/a	150

Fuse Reference - Ferraz Shawmut series (type)
Main Power: AJT (Time-delay Class J)
CPT Primary: ATQR (Time-delay Class CC)
CPT Secondary: TRM (Time-delay Midget)

TROUBLESHOOTING

Drive

For drive-specific issues, refer to the *FRENIC-Eco* drive instruction manual (INR-SI47-1225-E).

Motor Rotation

- Problem: Motor turns incorrect direction.
Solution: Swap two of the three motor output connections.