

## Mounting Adapter for External Cooling "PB-F1/E1"

Thank you for purchasing the Mounting Adapter for External Cooling PB-F1/E1. This adapter allows you to mount your FRENIC-Eco/FRENIC-Multi series of inverters on the panel in such a way that the heat sink assembly may be exposed to the outside. Using this adapter greatly reduces heat radiated or spread inside the panel enclosure.

### ⚠ CAUTION

- Do not touch the sharp edges of metallic components.  
**Doing so could cause injuries.**
- Do not use screws other than the ones included in the kit.  
**Doing so could cause a drop of the inverter and injuries.**
- Do not support the inverter by the terminal cover or the front cover during moving or transporting the inverter.  
**Doing so could cause a drop of the inverter and injuries.**
- Prevent lint, paper fibers, sawdust, dust, metallic chips, or other foreign materials from getting into the inverter or from accumulating on the heat sink.  
**Otherwise, a fire or an accident might result.**
- Do not install or operate an inverter that is damaged or lacking parts.  
**Doing so could cause fire, an accident, or injuries.**



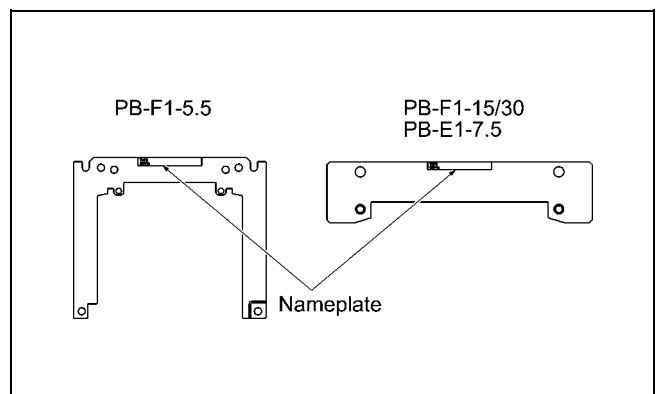

#### 1. Check that:

- (1) All the component parts of the adapter including the screws and nuts are contained in the package. Types of screws and nuts vary depending on the model of the adapter. See "2. Mounting Adapter Models and Applicable Inverter Models" for details.
- (2) The adapter is not damaged during transportation - no dents, bends, warp, or scratches.
- (3) The adapter is the model you ordered and the model name of the adapter printed on the nameplate (shown at the right) matches your inverter model (see the table on the next page).

If you suspect the product is not working properly or if you have any questions about your product, contact your Fuji Electric representative.

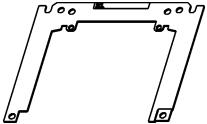

## 2. Mounting Adapter Models and Applicable Inverter Models

Model Name of Adapter and Accompanying Screws and Nuts			Applicable Inverter Models	
PB-F1-5.5  A set of upper and lower adapter plates	4 (M5 × 8) cross recessed head tapping screws	FRENIC-Eco	FRN001F1S-2U FRN002F1S-2U FRN002F1S-2U FRN005F1S-2U FRN007F1S-2U	
	6 (M6 × 15) cross recessed pan head screws with captive washer		FRN001F1S-4U FRN002F1S-4U FRN003F1S-4U FRN005F1S-4U FRN007F1S-4U	
6 (M6) hexagon nuts				
PB-F1-15  1 adapter plate	6 (M8 × 25) cross recessed pan head screws with captive washer	FRENIC-Eco	FRN010F1S-2U FRN015F1S-2U FRN020F1S-2U	
	4 (M8) hexagon nuts		FRN010F1S-4U FRN015F1S-4U FRN020F1S-4U	
		FRENIC-Multi	FRN015E1S-2U FRN020E1S-2U	
			FRN015E1S-4U FRN020E1S-4U	
PB-F1-30  1 adapter plate	6 (M8 × 25) cross recessed pan head screws with captive washer	FRENIC-Eco	FRN025F1S-2U FRN030F1S-2U FRN040F1S-2U	
	4 (M8) hexagon nuts		FRN025F1S-4U FRN030F1S-4U FRN040F1S-4U	
PB-E1-7.5  1 adapter plate	6 (M5 × 15) cross recessed pan head screws with captive washer	FRENIC-Multi	FRN007E1S-2U FRN010E1S-2U	
	4 (M5) hexagon nuts		FRN007E1S-4U FRN010E1S-4U	

## 3. Cutting a Hole through the Panel

Cut a mounting hole in the shape according to the model dimensions as shown below.

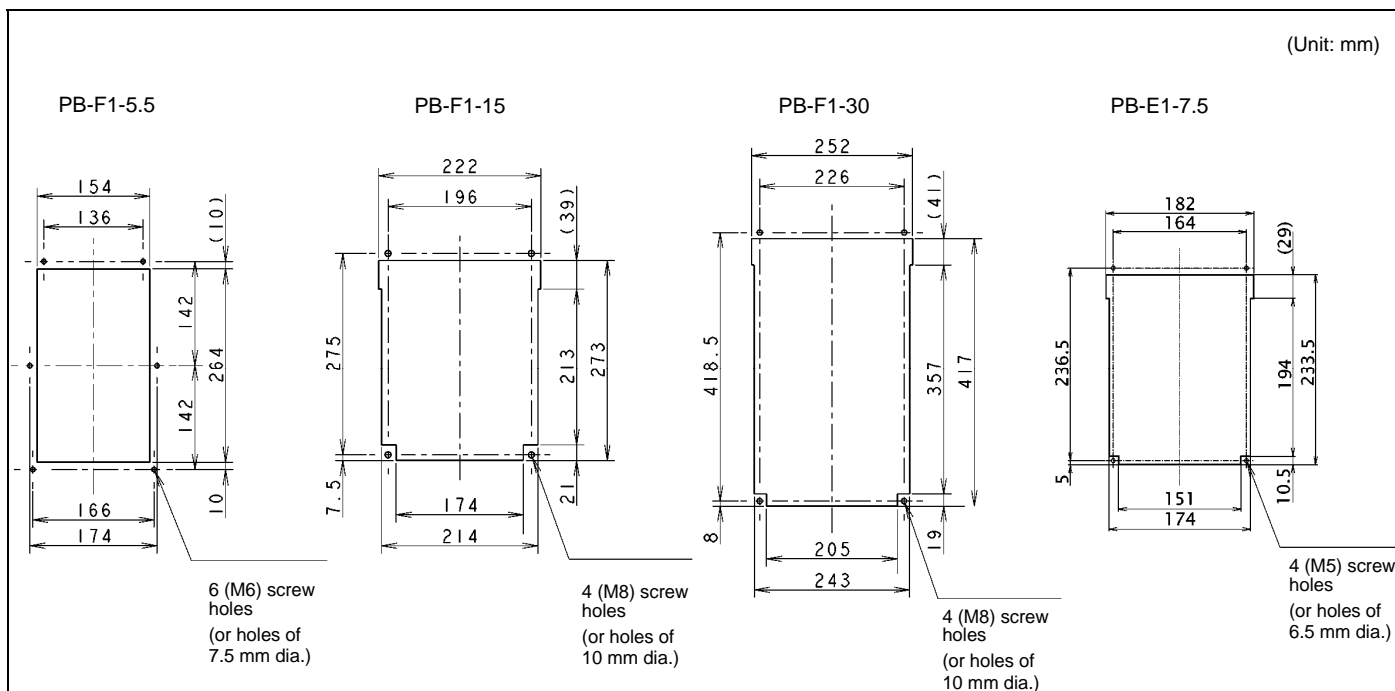

## 4. Installation

### ■ PB-F1-5.5

- (1) Insert the upper and lower adapter plates into slits "A" on the sides of the heat sink of the inverter as shown below. Make sure that the nameplate on the upper adapter plate faces towards the front. Make sure also that the upper and lower adapter plates engage properly with each other at joint "B."
- (2) Fix the upper and lower adapter plates to the rear of the heat sink with four (M5 × 8) tapping screws included in the kit (tightening torque: 3.5 N·m(2.58 lbf·ft)).
- (3) Mount the inverter onto the panel and fix it with six (M6 × 15) pan head screws and six hexagon nuts included in the kit (tightening torque: 5.8 N·m(4.28 lbf·ft)). If the panel has (M6) screwed holes, the hexagon nuts are not needed.

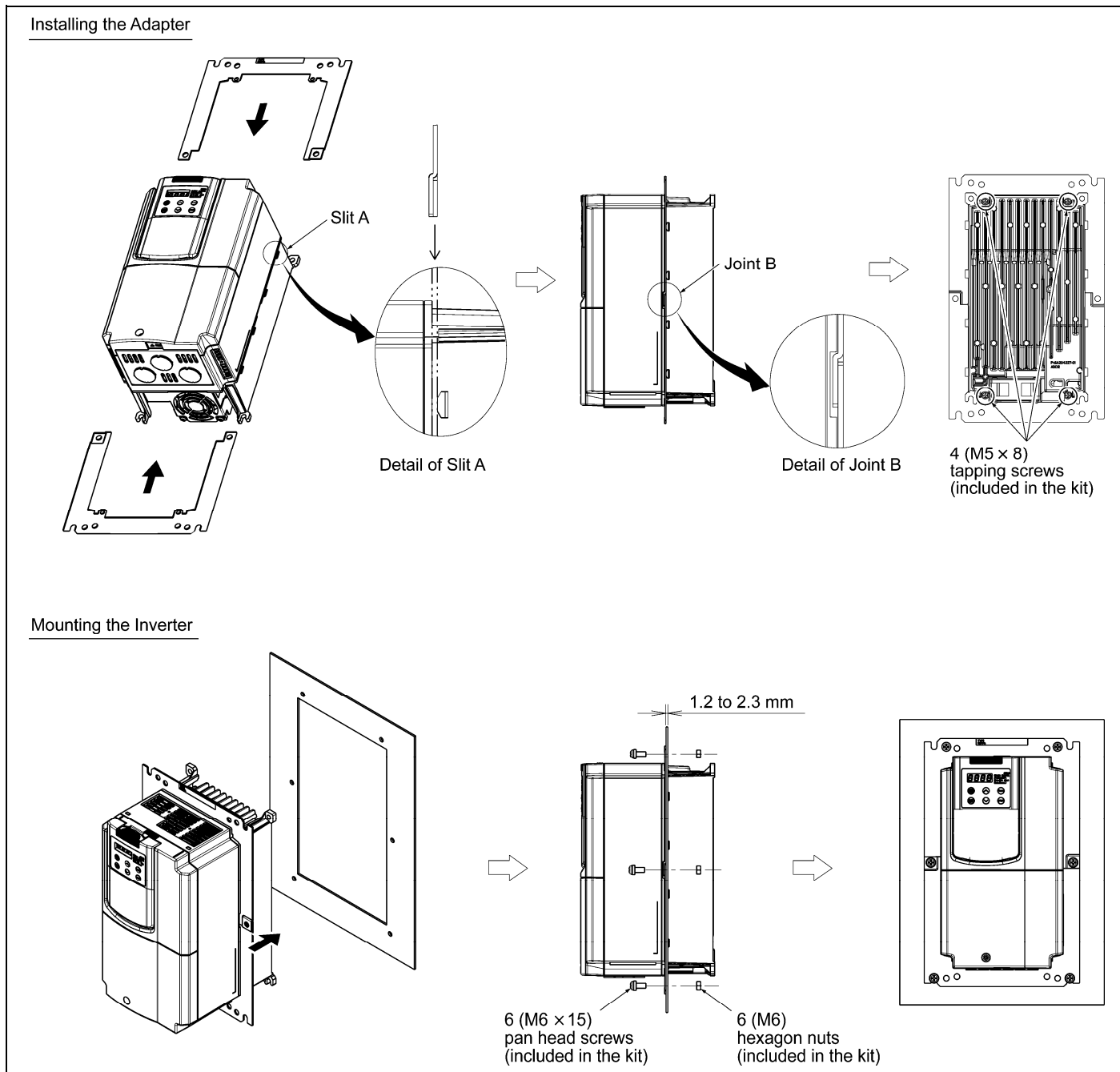

■ PB-F1-15/30, PB-E1-7.5

- (1) Fix the adapter plate onto the inverter with two pan head screws (PB-F1-15/30: M8 × 25, PB-E1-7.5: M5 × 15) included in the kit as shown below.  
(Tightening torque: PB-F1-15/30; 13.5 N·m(9.96 lbf·ft), PB-E1-7.5; 3.5 N·m (2.58 lbf·ft))
- (2) Insert legs "C" of the inverter through opening "D" of the panel at an angle, and in the upright position, fix the adapter and the inverter to the panel using four pan head screws (PB-F1-15/30: M8 × 25, PB-E1-7.5: M5 × 15) and four hexagon nuts (PB-F1-15/30: M8, PB-E1-7.5: M5) included in the kit.  
(Tightening torque: PB-F1-15/30; 13.5 N·m(9.96 lbf·ft), PB-E1-7.5; 3.5 N·m(2.58 lbf·ft))  
If the panel has screwed holes (PB-F1-15/30: M8, PB-E1-7.5: M5), the hexagon nuts are not needed.

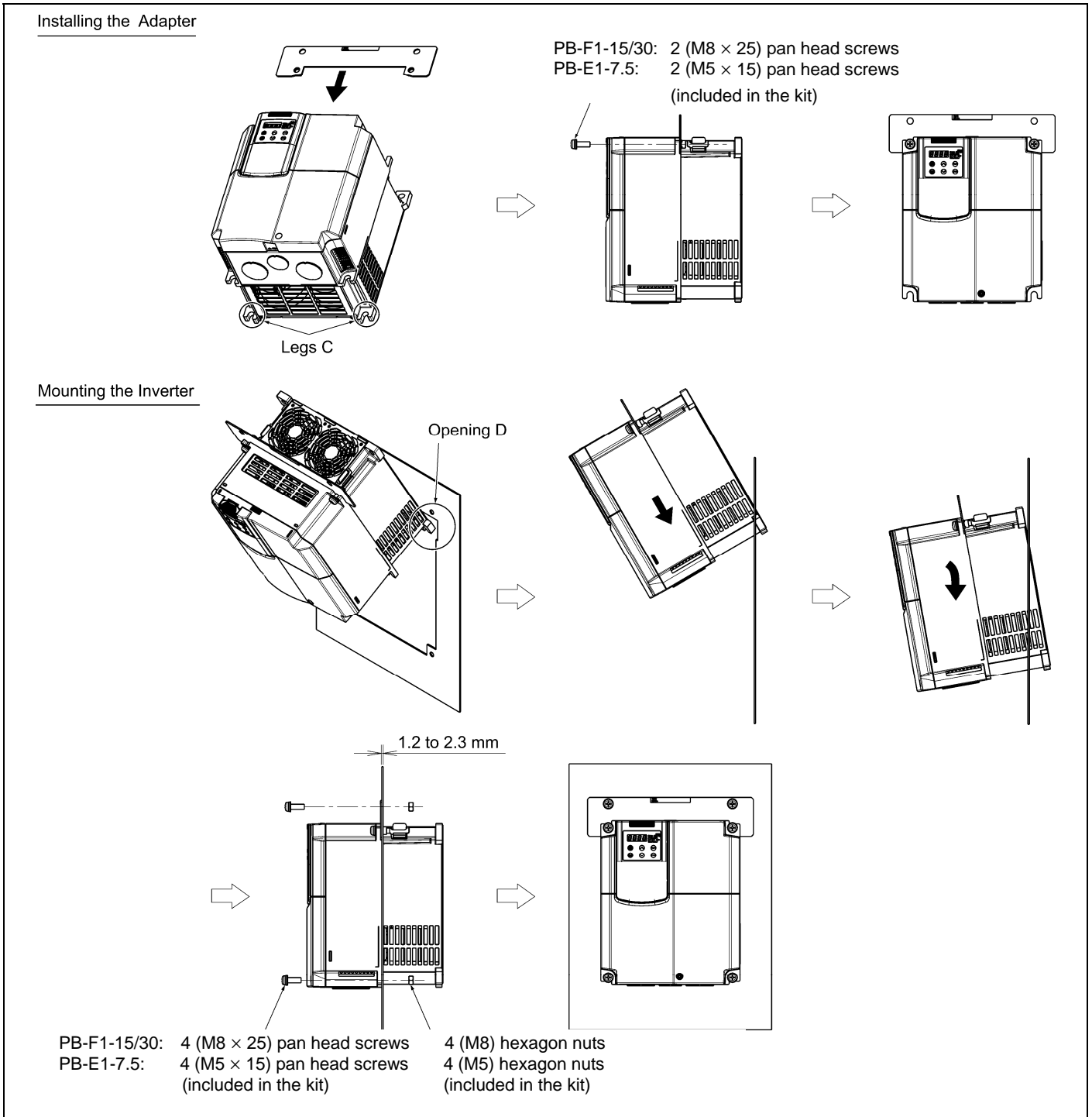

**Fuji Electric Systems Co., Ltd.**  
**Fuji Electric Corp. of America**

47520 Westinghouse Drive Fremont, CA 94539, U.S.A.

Tel.+1-510-440-1060 Fax.+1-510-440-1063

Toll-free support 1-888-900-FUJI(3854)

INR-SI47-0880a-EU REV. 052010

<http://www.fujielectric.com/fecoa/>

Information subject to change without notice.