

# A 2nd Generation Micro DC-DC Converter

Isao Sano  
Yoshikiyo Usui  
Tomonori Seki

## 1. Introduction

While miniaturization of cell phones, digital still cameras, portable music players and other types of portable electronic equipment is being accelerated, lower current consumption is being required in order to enable longer continuous usage of batteries. For this purpose, the power supply control ICs installed in such equipment are required to have a smaller footprint and to operate at higher efficiency to the extent possible.

In response to these requirements, micro DC-DC converters that integrate a control IC and an inductor have been developed and commercialized.

The originally developed prototype had a monolithic structure in which a thin film inductor was formed on the control IC, and although a thinner package was realized, problems remained with the product size and efficiency.

Thereafter, using a structure in which a dual-purpose substrate on which an inductor is mounted is connected to a control IC by flip chip bonding, the problems associated with the prototype were solved and a 1st generation product was commercialized.

This paper introduces Fuji Electric's newly developed FB6831J, a 2nd generation micro DC-DC converter that realizes an even smaller size.

## 2. Features

The micro DC-DC converter, as shown in Fig. 1, achieves a smaller size as well as a fewer components

Fig.1 Micro DC-DC converter configuration

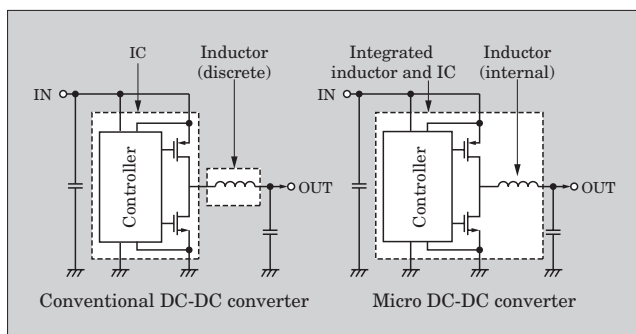

configuration by integrating the discrete inductor, selectable by the user according to the application in a conventional DC-DC converter, with the control IC. The concept of the micro DC-DC converter is to provide a DC-DC converter that is as easy to use as a LDO (low drop out) regulator.

Figure 2 shows the external appearance of the mi-

Fig.2 External appearance of micro DC-DC converter

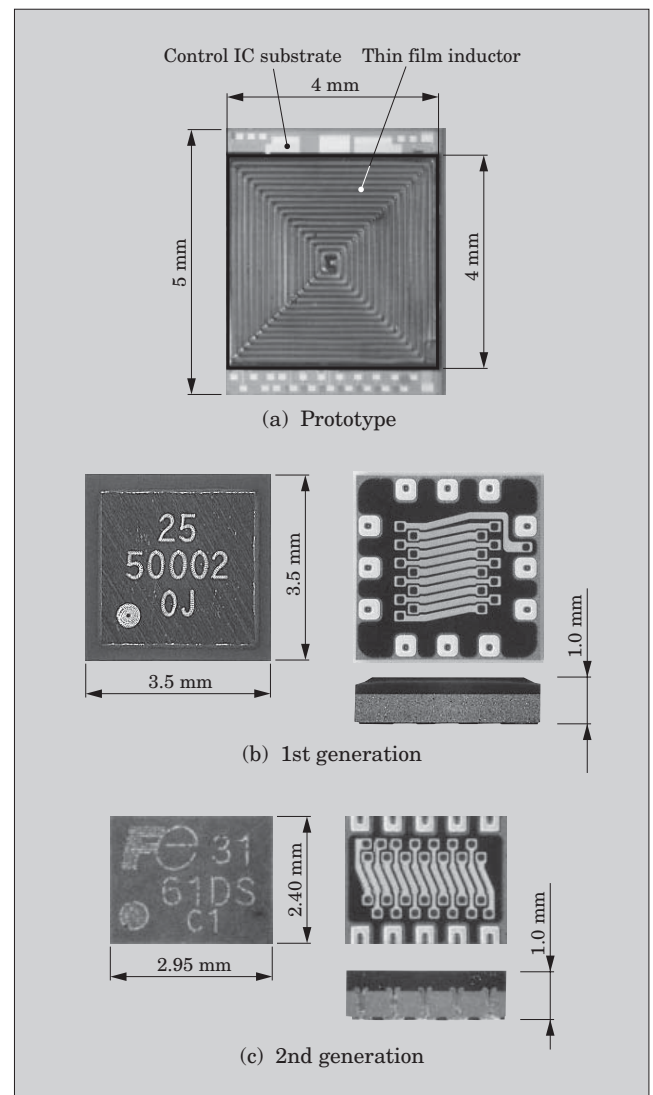

cro DC-DC converter. The product footprint has been reduced by approximately 40 % with each successive generation.

The FB6831J is a micro DC-DC converter that has step-down output voltage from the input voltage of a single-cell Li-ion battery. The FB6831J has a maximum output current of 500 mA.

Main features of the FB6831J are listed below.

- (1) External dimensions: As shown in Fig. 2(c), the FB6831J realizes dimensions of 2.95 mm × 2.40 mm, and a thickness of 1 mm (typ).
- (2) Package: As shown in Fig. 2(c), by using a CSM (chip size module) having ten terminals arranged on two sides, a micro DC-DC converter module of almost the same size as the die size is realized
- (3) Terminal configuration: The use of a SON (small outline non-lead) structure in which the terminals do not extend from the exterior of the package (PKG) contributes to the smaller footprint.
- (4) Inductor:  $L = 1.25 \mu\text{H}$  (300 mA),  $R_{dc} = 0.1 \Omega$   
As shown in Fig. 2(c), the inductor structure has the same toroidal shape as the 1st generation converter, but the terminals are arranged on two sides. Further, by increasing the percentage of area occupied by the inductor coil pattern, the module area size has been reduced down to 60 % while an inductance value of 75 % that of the 1st generation converter is obtained. Using a thick film for the coil conductor has achieved an approximate 50 % reduction in  $R_{dc}$ . Moreover, by selecting a ferrite-based substrate material with lower core loss, the design was optimized to resist magnetic saturation.

- (5) Protection circuit: The FB6831J is equipped with an internal protection circuit to protect against such abnormal conditions as shorting to ground, chip overheating and UVLO (under-voltage lock out), and also to provide overcurrent protection. When an abnormal condition is detected, the protection circuit suspends operation of the chip. Setting the CE terminal to an L-level voltage releases the protection state, and setting the terminal to an H-level voltage returns the chip to its normal operation.
- (6) Switching frequency: 2.5 MHz  
High-speed operation is realized through optimized design of the dead time control, driver circuits, high-speed comparators, and oscillation circuits.
- (7) Low current consumption: Standby mode: 1  $\mu\text{A}$ , Operating mode: 300  $\mu\text{A}$   
Each circuit cell was designed for low current consumption to realize the low level of current consumption required in portable electronic equipment.

The main electrical characteristics of the FB6831J are listed in Table 1.

### 3. Module Technology for the Micro DC-DC Converter

The structures of the prototype, 1st generation and 2nd generation models are compared in Table 2. The 2nd generation micro DC-DC converter assembly uses low loop wire bonding to realize a product thickness of 1 mm (typ).

Table 1 Main electrical characteristics

Item	Symbol	Condition	min	typ	max	Unit
Power supply voltage	$V_{DD}$		2.7	3.6	5.5	V
Current consumption	$I_{VDD1}$	VDD Pin CE = L	–	0.1	1	$\mu\text{A}$
	$I_{VDD2}$	VDD Pin CE = H, Unloaded	60	80	100	$\mu\text{A}$
	$I_{PVDD1}$	PVDD Pin CE = L	–	0.1	1	$\mu\text{A}$
	$I_{PVDD2}$	PVDD Pin CE = H, $I_{OUT} = 300 \text{ mA}$ $V_{OUT} = 1.5 \text{ V}$	–	145	165	mA
Output voltage range	$V_{OUT}$	$I_{load} = 0 \text{ to } 500 \text{ mA}$	0.8	–	$V_{IN} - 0.7$	V
Output voltage accuracy	$V_{OUTA}$	$I_{load} = 0 \text{ to } 500 \text{ mA}$ , $V_{OUT} = 1.5 \text{ V}$	–3	–	3	%
Output ripple voltage	$V_{ripple}$	$V_{OUT} = 1.5 \text{ V}$ , $I_{load} = 300 \text{ mA}$ , Capacitor ESR < 100 m $\Omega$	–	–	40	mVp-p
		$V_{OUT} = 1.5 \text{ V}$ , $I_{load} = 500 \text{ mA}$ , Capacitor ESR < 100 m $\Omega$	–	–	50	mVp-p
Maximum efficiency	$\eta_1$	$V_{OUT} = 1.8 \text{ V}$ , $I_{load} = 200 \text{ mA}$	–	90	–	%
	$\eta_2$	$V_{OUT} = 1.5 \text{ V}$ , $I_{load} = 200 \text{ mA}$	–	85	–	%
Oscillation frequency	$f_{OSC}$	$I_{OUT} = 50 \text{ mA}$	2.3	2.5	2.7	MHz
UVLO ON threshold voltage	$V_{UVLH}$		2.3	2.4	2.5	V
UVLO OFF threshold voltage	$V_{UVLL}$		2.2	2.3	2.4	V

Table 2 Structural comparison

	Prototype	1st generation	2nd generation
Assembly structure	Monolithic structure	Flip chip bonding	Wire bonding
Cross section			

Fig.3 FB6831J block diagram



In the 1st generation assembly that used flip chip bonding, control IC pads were arranged at fixed locations, and therefore the chip size of the control IC could not be reduced due to the constraint of the inductor size. The newly developed assembly uses wire bonding, which allows for a greater degree of freedom in the positioning of the control IC pads and in determining the chip size, enabling cost-effective optimal chip design. On the other hand, because wire bonding has higher wire resistance than flip chip bonding, multiple wires are installed for the large current, low impedance terminals. After the wire bonding has been completed, the control IC surface is coated with a liquid resin, and the inductor substrate is diced to form the individual micro DC-DC converters.

#### 4. Application Circuit

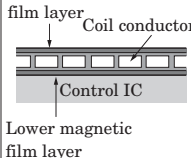
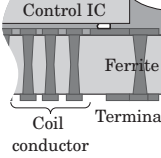
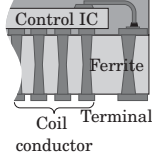
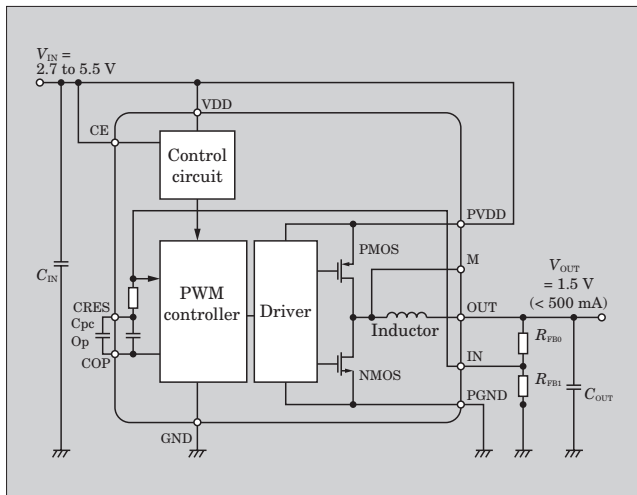
Figure 3 shows a block diagram and Fig. 4 shows an example application circuit of the FB6831J. Because this product is equipped with an internal inductor, an output MOS (metal oxide semiconductor) and a phase compensation circuit, the only external parts are I/O capacitors and voltage-setting resistors, to configure a buck converter, FB6831J contributes greatly to the

Fig.4 Example application circuit

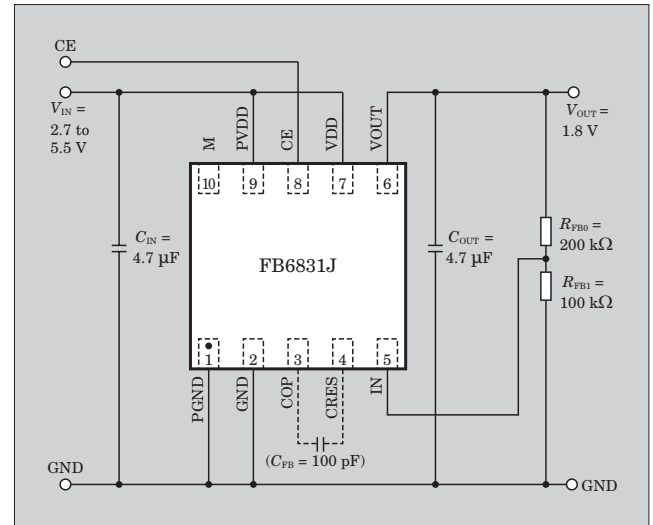
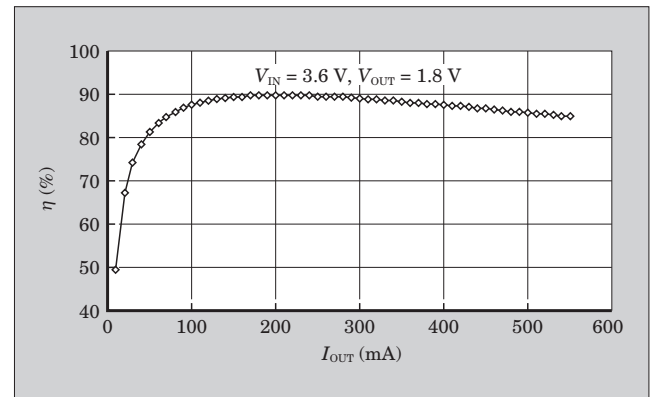

Fig.5 FB6831J efficiency



miniaturization of portable electronics equipment.

The newly developed FB6831J incorporates the following innovations to realize higher efficiency.

- (1) Control circuit (IC): Optimized dead time, lower current consumption of each block, optimized oscillation frequency
- (2) Output MOS (device) size: Size has been optimized such that conductive loss, low gate charge loss, and low drain capacitance loss are a minimum at the switching frequency.
- (3) Inductor: Selection of substrate material that reduces core loss. Terminal arrangement that optimizes the coil pattern area

An actual measurement example of efficiency is shown in Fig. 5.

High efficiency of 90 % is realized at  $V_{IN} = 3.6 V$ ,  $V_{OUT} = 1.8 V$  and  $I_{OUT} = 200 mA$ .

Use of the newly developed and commercialized FB6831J enables the construction of a DC-DC converter system enabling a smaller and thinner assembled device, and longer battery life.

## 5. Conclusion

The FB6831J has been introduced as a 2nd generation DC-DC converter module for use with a single-cell Li-ion battery in applications mainly in portable electronic equipment including cell phones, digital still cameras and the like.

In the future, Fuji Electric plans to add to its product lineup a micro DC-DC converter that supports various input voltages and output voltages. Fuji Electric also intends to continue to develop inductor

material capable of ensuring the required inductance values even when the physical size of the inductor is small, and to develop a low  $R_{on}Q_g$  device having low gate charge loss and low drain capacitance loss even when the switching frequency is high to realize higher efficiency and smaller size.

## Reference

- (1) Hayashi, Z. et al. High-Efficiency DC-DC Converter Chip Size Module With Integrated Soft Ferrite. THE 2003 INTERNATIONAL MAGNETICS CONFERENCE (INTERMAG 2003).

