

Fuji Electric ELCB & MCCB Lockout/Tagout Devices for

# Semiconductor Application

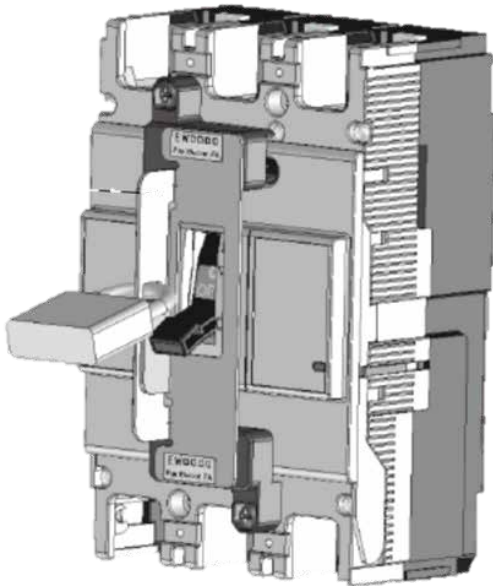

BW9Q2GA

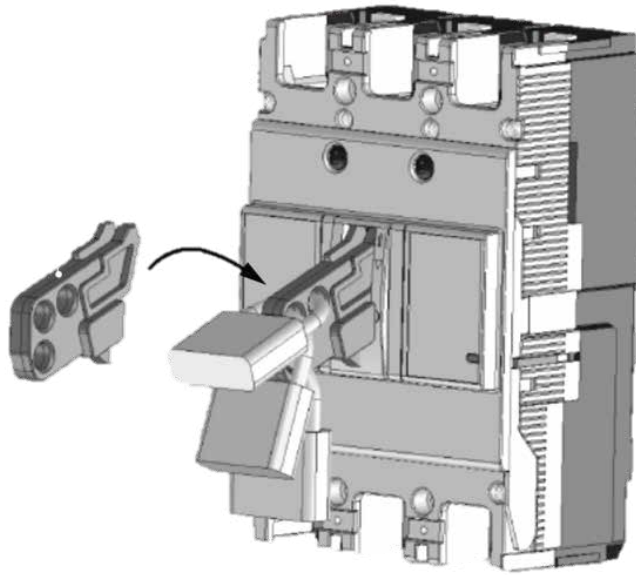

BW9Q1CA

## Lockout/Tagout (LOTO) Devices

- ✓ New plate-type padlocking device available for G-TWIN 50A/100A frame sizes
- ✓ Offer both removable (cap type) and non-removable (plate-type) LOTO devices
- ✓ Safety conformance to SEMI standards SEMI S2-0715a: 17 and SEMI S22-0715b: 8.14

### ■ Specifications

#### ■ G-TWIN Series

AF	Applicable Breakers	Padlocking Device	
		Q1: Cap Type	Q2: Plate Type
50	BW50RAGU, EW50RAGU	BZ6L10CA	Q2-0A355 *
100	BW100, EW100		
125	BW125, EW125	BW9Q1CA	BW9Q2CA
250	BW250, EW250		BW9Q2GA

\* Product is only available as factory installed. Suffix "Q2-0A355" needs to be added to circuit breaker part number for the plate-type padlocking device

#### ■ Lambda Series

AF	Applicable Breakers	Padlocking Device	
		Q1: Cap Type	Q2: Plate Type
50	BW50RBGU, EW50RBGU	BW9L1BA-P	BW9Q2BA *

\* Product is field installable and sold separately

■ Dimensions [unit: mm]

■ G-TWIN Series 50AF/100AF Factory Assembled Q2 Device (Q2-0A355)

● 2-pole

● 3-pole

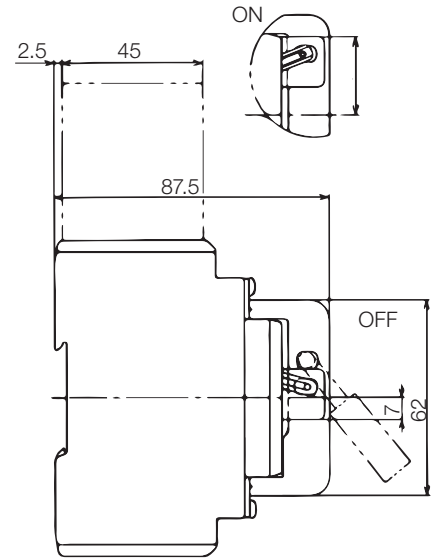
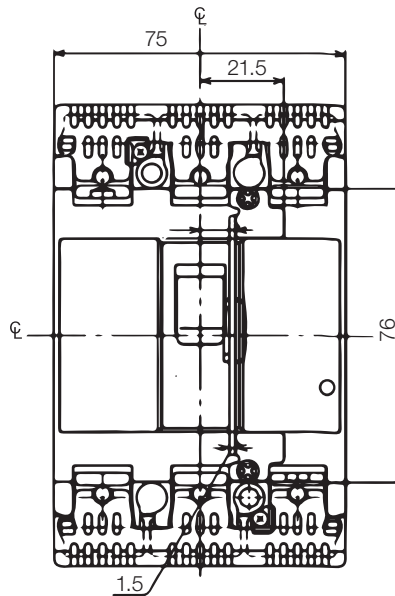
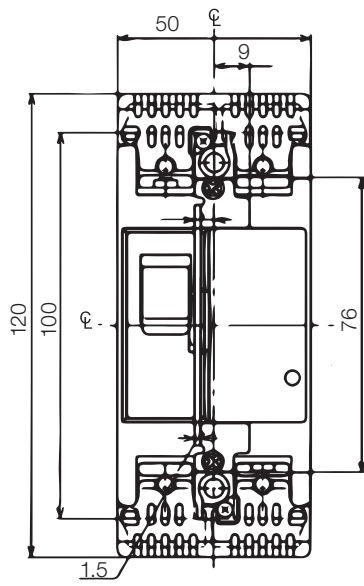

■ BZ6L10CA

● ON Locking

● OFF Locking

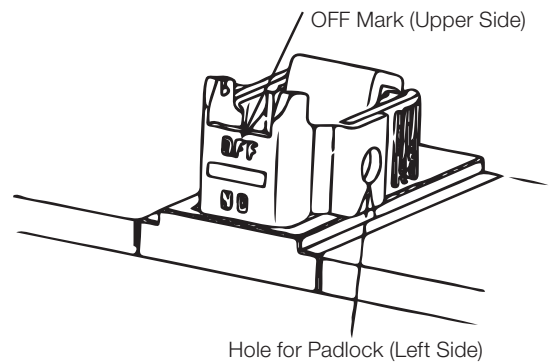
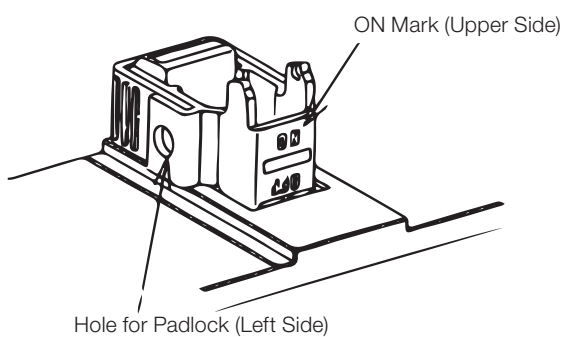
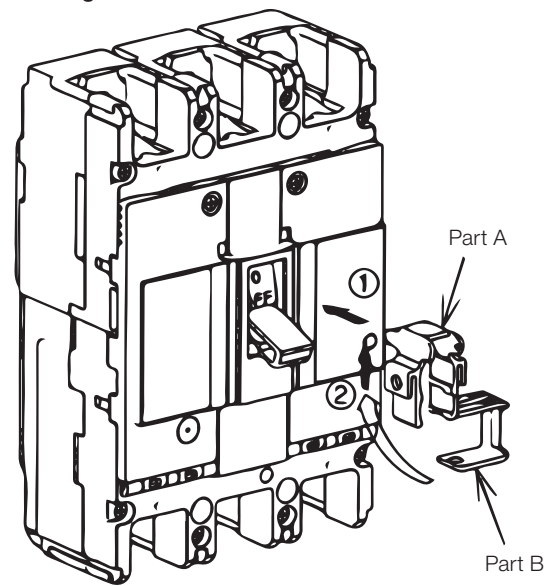
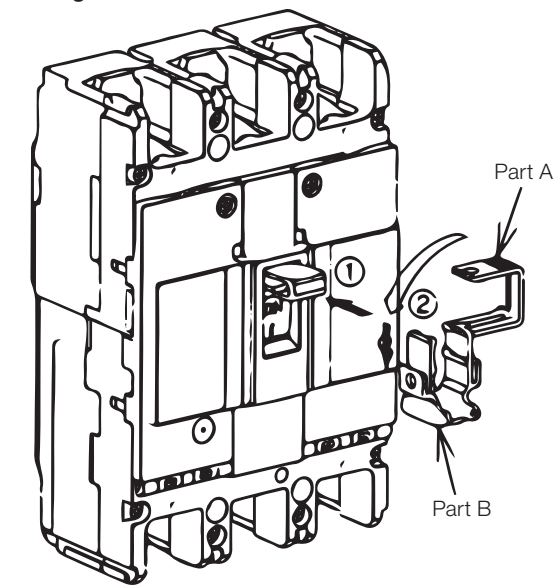

**Fuji Electric Corp. of America**

47520 Westinghouse Drive, Fremont, CA 94539

Phone: 510-403-7860

x-fea-fuji-dc@fujielectric.com

www.americas.fujielectric.com

Information in this datasheet is subject to change without notice.