



Innovating Energy Technology

Variable Torque Load Inverters for Fans and Pumps

# FRENIC-ECO Series



# FRENIC Eco



FUJI ELECTRIC INVERTERS

GREAT PERFORMANCE THROUGH DEDICATED DESIGNS



FECA-BR-MEH532

# Variable Torque AC Drives for Fans and Pumps!



## Enhanced Energy Savings

### Optimizing Energy-Savings for the complete system

In addition to optimizing the control of the applied motor for Energy-Savings, FRENIC-Eco series drives also optimizes power consumption of the drive for maximizing Energy-Savings for the complete system. With regulations expected to call for a reduction of 1% or more in annual energy consumption, Fuji Electric is aiming to optimize energy-savings as a complete system approach and not focusing only on reducing energy consumed by the motor.

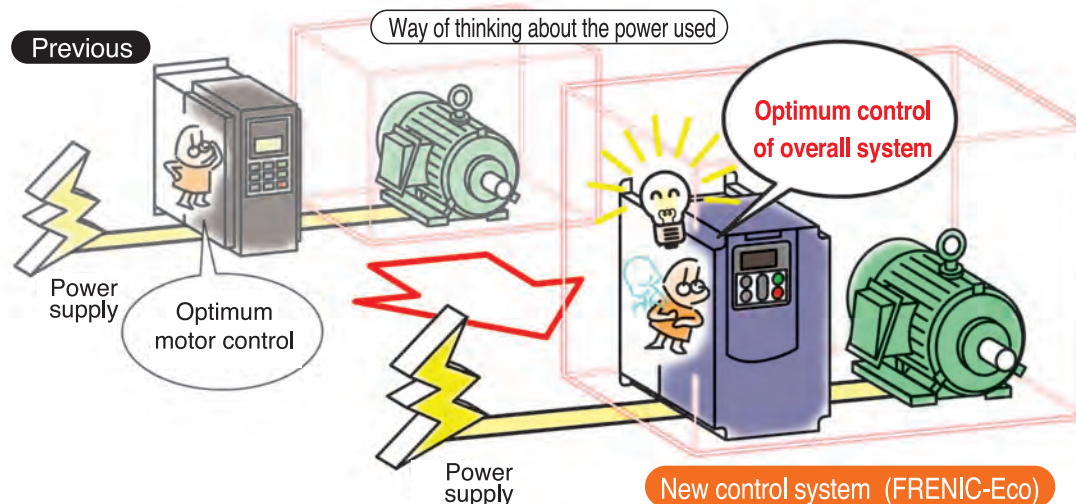

Using this new system, energy savings is several percent improved over that of the previous models.

Kyoto Agreement, which was studied at the Conference on Prevention of Global Warming (COP3), was ratified by Russia in October 2004, and thereby put into effect on February 16, 2005. In the future, the related regulations are calling for a reduction in energy consumption of 1% or more each succeeding year, and therefore, we are aiming to build energy saving features into equipment as a whole. **FRENIC-Eco is the inverter equipped with the industry's highest level of efficiency (low power loss).**

### Power Monitor

Power-related data can be checked via the inverter unit's keypad.

Items
Power (kW)
Cumulative power (kWh)
Cumulative power rates (\$/kWh)

\* Cumulative values can be reset. Cumulative power rates are shown with the power rate set as so much per kWh (display coefficient). Rates in other currency can also be displayed.

nEnergy saving effect compared with Fuji's previous models

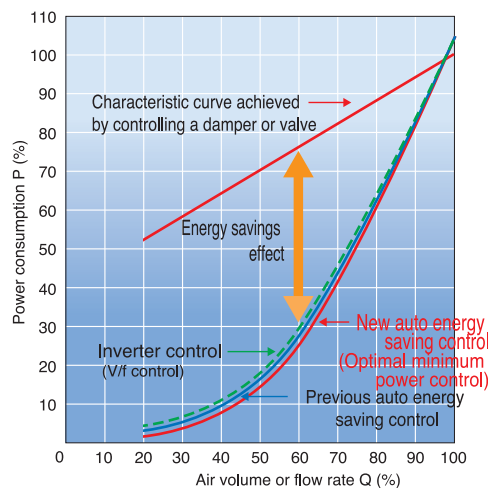

(The effect varies dependent on the motor's characteristics.)



## Long life design that meets your expectation

### Built with longer lasting replaceable components to give a longer service life!

3 Year Product Warranty

The design life of replaceable components in each inverter model has been extended to **10 years**. In addition, the capacity of the main circuit capacitors is measured and temperature compensation carried out to match the cumulative operating time of the electrolytic capacitors on the printed circuit board.

Life-limited component name	Designed life
Main circuit capacitors	10 years
Electrolytic capacitors on printed circuit board	10 years
Cooling fan (Note)	10 years

Note: 7 years for 50HP or larger models  
[Conditions] Ambient temperature: 40°C (104°F). Load factor: 80% of inverter's rated current  
\*The life may be shorter depending on surrounding conditions.

# Saves energy and cuts costs.



Maintenance is simplified for both the drive and equipment

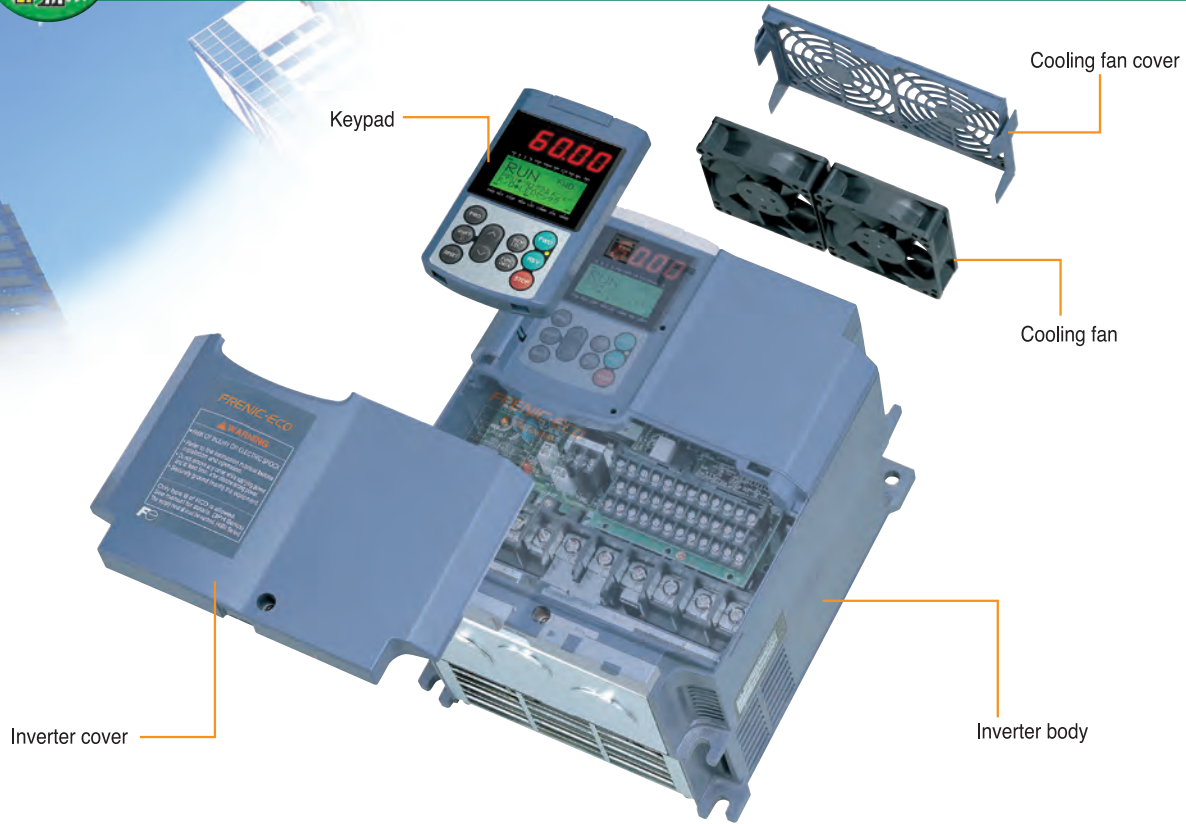

## The service life information for replaceable inverter components is displayed.

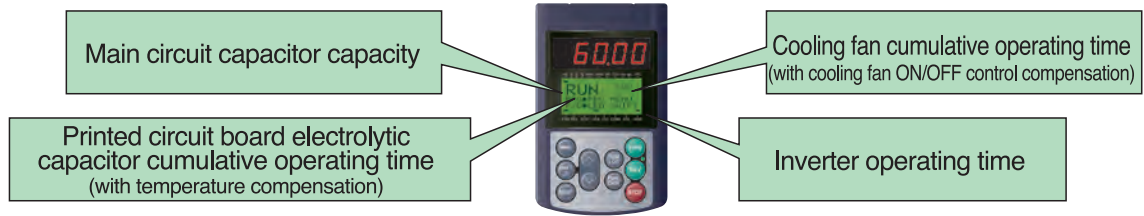

## Simple replacement of replaceable components

### Cooling fan replacement procedure

I20HP model



Cooling cover can be removed with one touch.



Disconnect the power connector and change the cooling fan cartridge.

I60HP model



The inverter's mounting screws and power connector can be removed from the front.



The cooling fan cartridge can be replaced by sliding the holder out to the front

Industry first

## Information is displayed with equipment maintenance in mind.

In addition to maintenance information for the inverter unit, information related to equipment maintenance is also displayed.

Item	Purpose
Motor cumulative operating time (hours)	The cumulative operating time of the equipment the inverter is used with is calculated. <b>Example of Use</b> If the inverter is used for fan control, this time can be used as a criterion for replacing the belts used on pulleys.
Number of starts (times)	The number of times the inverter is run and stopped can be counted. <b>Example of Use</b> The number of times the equipment is started and stopped is recorded, so this can be used as a criterion for replacing parts in equipment where starting and stopping is a burden on the machine.



# Equipped with the optimum functions for Fans and Pumps

## Operation is continued even after the momentary power failure thanks to the auto-restart function.

Even if a momentary power failure occurs, load inertia of a fan or blower, etc. is used to maintain the motor's operation while the motor's operating speed gradually drops, and enables the motor to restart operation without stopping. (The motor may stop on occasion due to the load's inertia.)

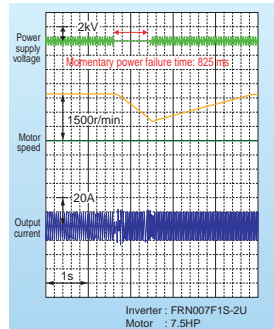

## A pick-up function provides smooth starts.

If you desire to run a fan which the inverter is not currently running and which is turning free. This function will pick up on its motion regardless of the direction it is turning and take operation. Momentary switching is performed in the inverter from the commercial power supply and provides a convenient function when starting motors, etc.

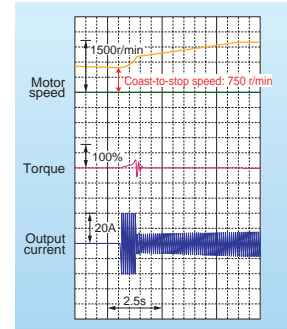

## Tripless operation through regenerated current avoidance control

Deceleration time is controlled to match the internal energy level generated in the inverter, and so deceleration and stopping is accomplished without tripping due to overload.

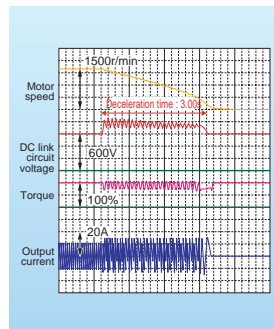

## Even greater energy savings through the low water volume stop function

When there is pump operation accompanying "pressure drop" that occurs due to pressure loss or leakage, etc. in the piping, etc., or at times when the pump runs repeatedly to obtain a small volume of water, this function controls the pump's operation, preventing it from being driven with the water volume below a predetermined level, and thus reducing wasteful pump operation and saving even more energy.

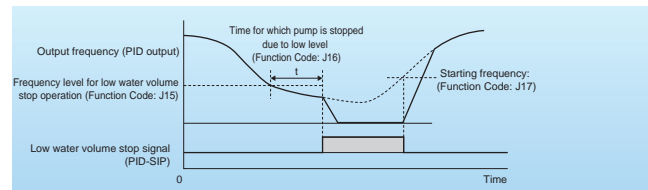

## The equipment's operating condition is determined by the low torque detection function.

The inverter determines the load state of the connected motor and if it drops below a predetermined level, it judges that a "Low Torque" state exists and outputs a signal to that effect. In this way, any trouble that occurs in the equipment (such as a belt on a pulley breaking) can be detected by the inverter.

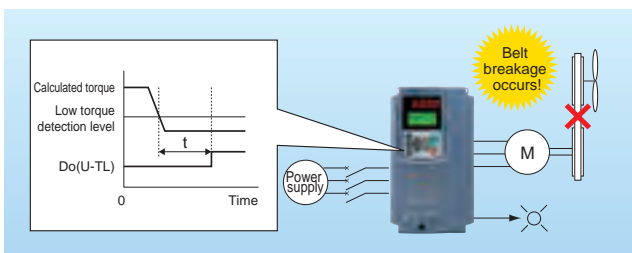

## Also avoids operation signal trouble through the command loss detection function.

If the frequency signals (0 to 10V, 4 to 20mA, multi-step speed operation signals, communications, etc.) that are connected to the inverter are lost, signals are output as a "command loss," indicating that a frequency command was lost. In addition, output frequency when the command loss occurred can be set in advance, so even if a frequency signal line to equipment is broken due to machine vibration, etc., machine operation can be continued uninterrupted.

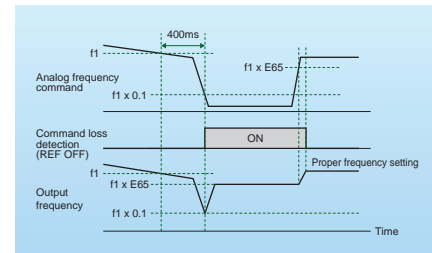

### Simple circuit configuration using the commercial line switching sequence

Inverters are equipped with the commercial line start function that enables switching between the commercial line and the inverter by an external sequence. In addition, inverters are equipped with two types of built-in sequence for operation with commercial line; i.e., Fuji's standard sequence and the automatic switching sequence to the commercial line activated when the inverter alarm occurs.

Note: The latter sequence differs from the one for forcible switching to the commercial line during inverter breakdown.

### Inverters are equipped with full PID control functions.

Low water level stop function, deviation alarm and absolute value alarm outputs have been added to the PID regulator which performs such tasks as temperature, pressure and flow rate control. In addition, an anti-reset windup function that prevents PID control overshoot as well as a PID output limiter and integral hold/reset signal provide easy-to-adjust PID control functions.

### Continuous equipment operation through overload avoidance control

If the load on a fan or pulley increases due some foreign object overloading around the shaft, etc., and the inverter's internal temperature rises suddenly or the ambient temperature rises to an abnormal level, etc., causing an inverter overload state, the motor's speed is lowered, reducing the load and enabling operation to continue.

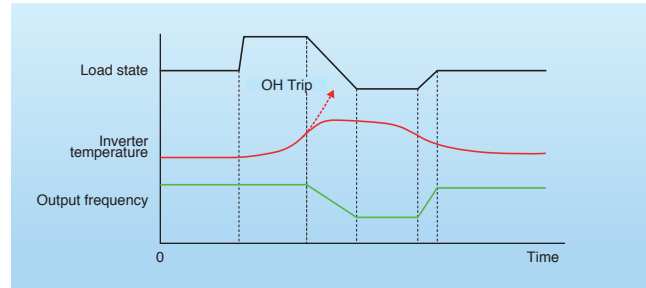

### Simple Sequences through Universal DI/DO

Signals can be transmitted to a higher level controller or PC by connecting digital signals to an inverter from different types of sensors, such as a float switch used to judge the level in a water storage tank, which serve as peripheral devices to the inverter. In the case of small-scale equipment, even if a programmable logic controller (PLC) is not used, information can be sent to a higher-level system easily.

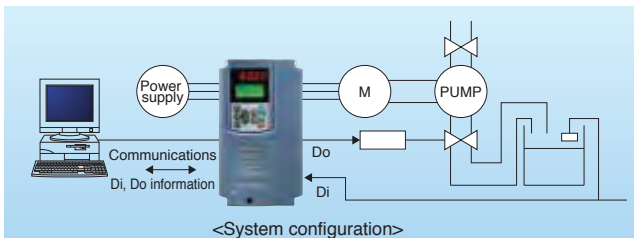

### Elimination of display devices by use of the analog input monitor

Using the display coefficient of signals from devices such as flow rate or temperature sensors in air conditioning equipment, these signals can be converted into physical values such as temperature and pressure and displayed on the inverter's keypad without making the use of exclusive flow meters or air flow meters.

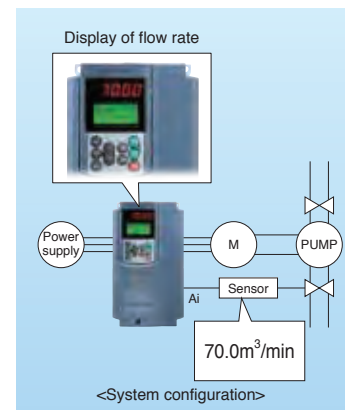

### Improved capability for handling regenerated energy

When the inverter slows down and stops the motor, if the braking energy regenerated by the motor exceeds the braking capacity of the inverter's main circuit capacitor, the inverter will trip. At such a time, if even a little excess energy trips the inverter, using this function you may be able to absorb the excess braking energy without connecting to a braking resistor.

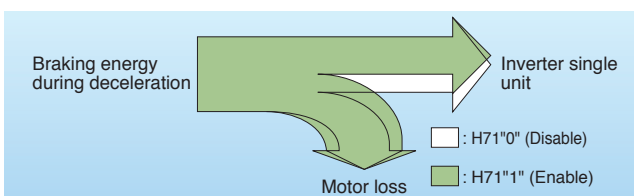

### Other convenient functions

#### Motor condensation prevention function

Prevents condensation of the motor from occurring in cases where the surrounding temperature changes suddenly while the motor is stopped.

#### Motor speed display with percent

The inverter's keypad displays the operating frequency (Hz) or the motor's rotational speed (r/min), but it can also display the maximum speed as 100%, so it is easy to get a grasp of the equipment's operating state.

## Dynamic Rotation of Pump Motors

### ●With a fixed inverter-driven motor

This configuration consists of a motor driven by the inverter (M0) and motors driven by commercial power (M1 to M4). The inverter-driven motor is fixed at M0 and is controlled for variable speed. When the inverter-driven motor M0 alone cannot sustain the desired discharge flowrate, the inverter starts one or more motors driven by commercial power as necessary.

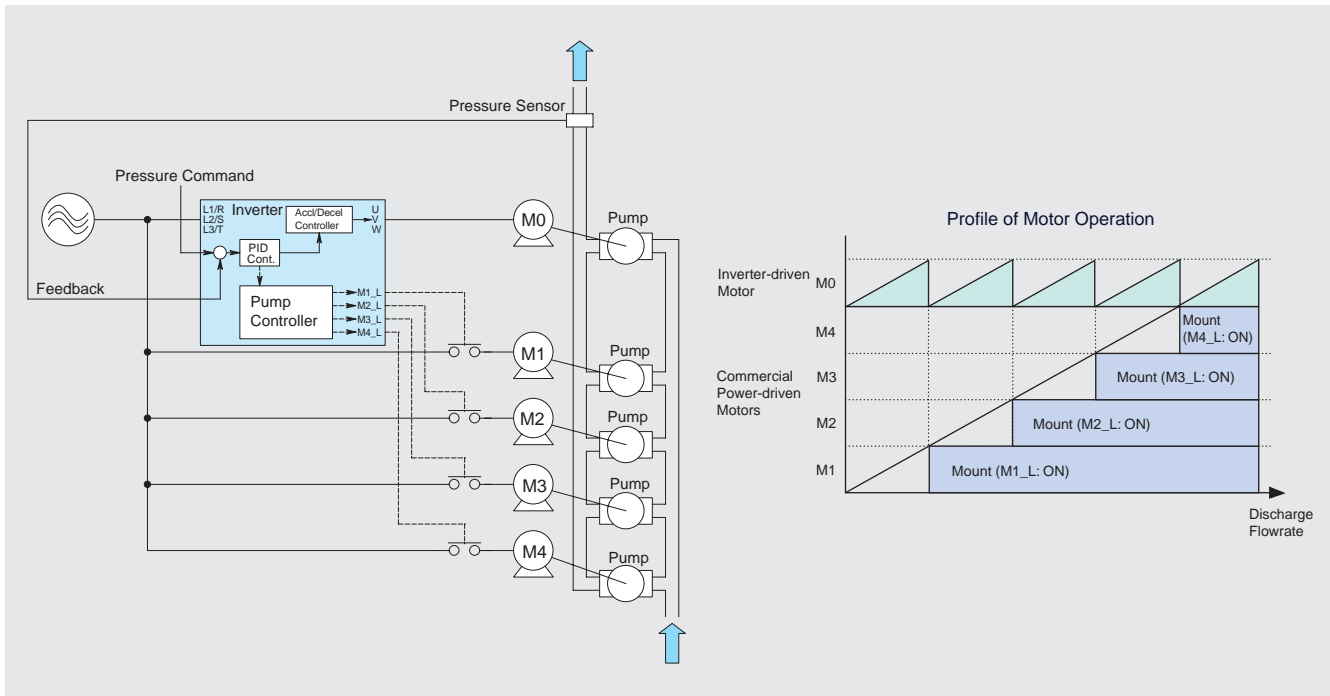

### ●With a floating inverter-driven motor

In this configuration, all the motors can be driven by the inverter or commercial power. At the start of operation, each motor is driven by the inverter and is controlled for varying speed. When the first motor alone cannot sustain the desired discharge flowrate, it is switched to commercial-power operation, and the inverter drives the second motor.

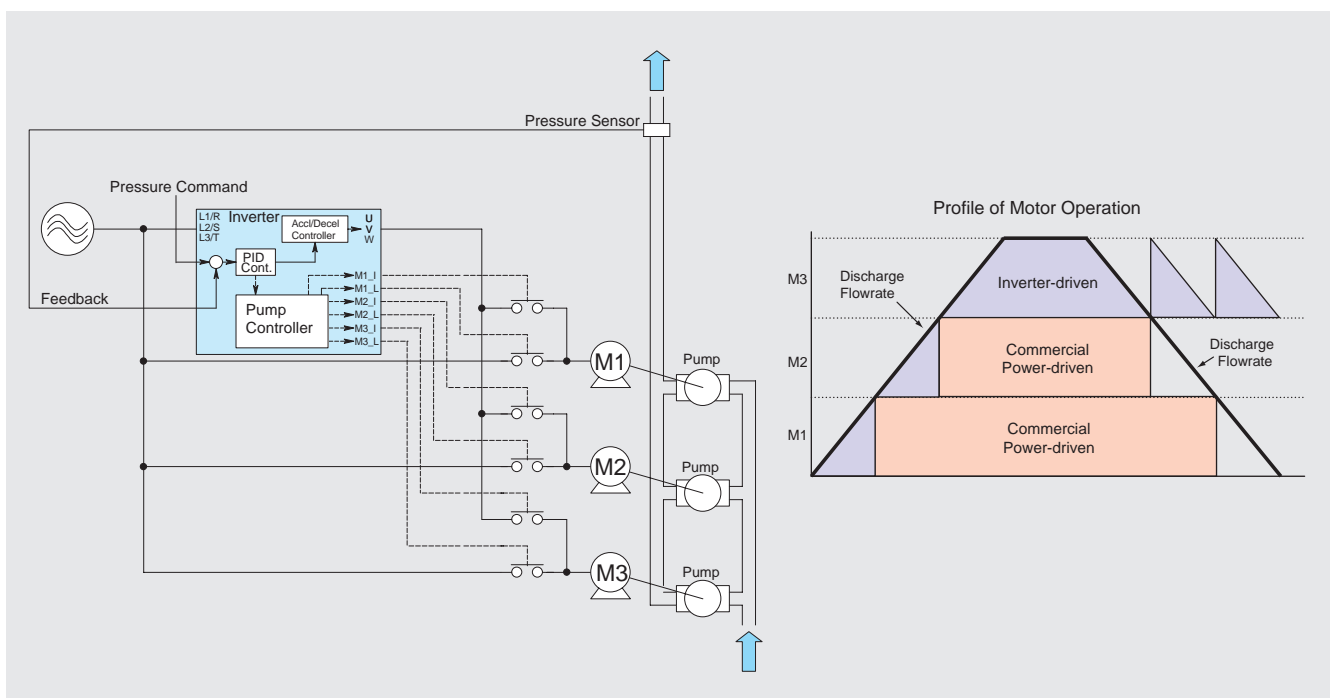



## Consideration of the surrounding environment and panel design

### Side-by-side installation saves space!

If multiple inverter units are to be used in a panel and the panel is designed accordingly, it is possible to mount these inverters side-by-side horizontally, so the panel can be designed to take up less space. (5HP for 208V, 7.5HP for 460V or smaller capacity inverters)

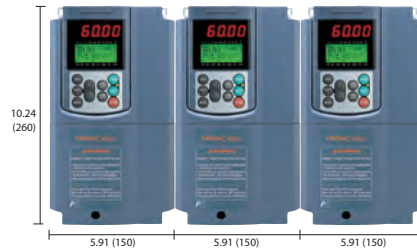

### Built-in charging resistors (in rush current suppressing resistors) help reduce peripheral equipment sizing!

When the FRENIC-Eco series is used, the charging resistors (in rush current suppressing resistors) built into the inverter as standard equipment suppress in rush current when motors are started, so compared to operation of motors with direct input, peripheral equipment with reduced capacity can be selected.

### Cooling outside the panel is made possible by an external cooling attachment!

Use of the external cooling attachment (optional on 30HP for 208V, 40HP for 460V or smaller inverters and standard on 40HP for 208V, 50HP for 460V or larger inverters) to cool the inverter outside the panel makes it possible to install a simple cooling system outside the panel.

## Multi-function keypad

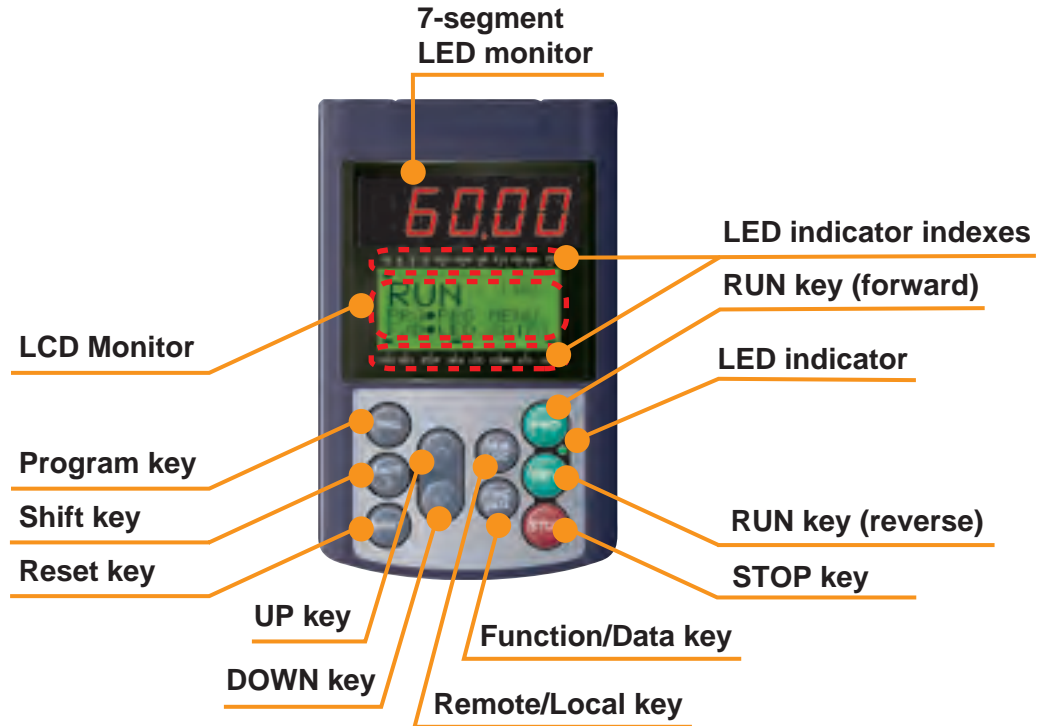

Item	Monitor, LED indicator or Key	Functions
LED/LCD Monitor		Five-digit, 7-segment LED monitor which displays the following according to the operation mode: <ul style="list-style-type: none"> <li>■ In Running Mode: Running status information (e.g., output frequency, current, and voltage)</li> <li>■ In Programming Mode: same as above</li> <li>■ In Alarm Mode: Alarm code, which identifies the cause of alarm if the protective function is activated.</li> </ul>
		LCD monitor which displays the following according to the operation modes: <ul style="list-style-type: none"> <li>■ In Running Mode: Running status information</li> <li>■ In Programming Mode: Menus, function codes and their data</li> <li>■ In Alarm Mode: Alarm code, which identifies the cause of alarm if the protective function is activated.</li> </ul>
	LED indicator indexes	In running mode, display the unit of the number displayed on the LED monitor and the running status information shown on the LCD monitor. For details, see next page.
Keypad Operation Key		Switches the operation modes of the inverter.
		Shifts the cursor to the right when entering a number.
		Pressing this key after removing the cause of an alarm will switch the inverter to Running Mode. Used to reset a setting or screen transition.
		UP and DOWN keys. Used to select the setting items or change the function code data displayed on the LED monitor.
Run Operation Key		Starts running the motor (forward rotation).
		Starts running the motor (reverse rotation).
		Stops the motor.
		Pressing this toggle key for more than 1 second switches between Local and Remote modes.
LED Indicator		Lights while a run command is supplied to the inverter.

Type	Item	Description (information, condition, status)
Unit of Number Displayed on LED Monitor	Hz	Output frequency, frequency command
	A	Output current
	V	Output voltage
	%	Calculated torque, load factor, speed
	r/min	Motor speed, set motor speed, load shaft speed, set load shaft speed
	m/min	Line speed, set line speed (Not applicable to FRENIC-Eco)
	kW	Input power, motor output
	X10	Data greater than 99,999
	min	Constant feeding rate time, constant feeding rate time setting (Not applicable to FRENIC-Eco)
	sec	Timer
Operating Status	PID	PID process value
	FWD	Running (forward rotation)
	REV	Running (reverse rotation)
Source of Operation	STOP	No output frequency
	REM	Remote mode
	LOC	Local mode
	COMM	Communication enabled (RS-485 (standard, optional), field bus option)
	JOG	Jogging mode (Not applicable to FRENIC-Eco)
HAND	Keypad effective (lights also in local mode)	



## Model List

Applicable motor rating (HP)	Standard type	
	Three-phase 208V	Three-phase 460V
1	FRN001F1S-2U	FRN001F1S-4U
2	FRN002F1S-2U	FRN002F1S-4U
3	FRN003F1S-2U	FRN003F1S-4U
5	FRN005F1S-2U	FRN005F1S-4U
7.5	FRN007F1S-2U	FRN007F1S-4U
10	FRN010F1S-2U	FRN010F1S-4U
15	FRN015F1S-2U	FRN015F1S-4U
20	FRN020F1S-2U	FRN020F1S-4U
25	FRN025F1S-2U	FRN025F1S-4U
30	FRN030F1S-2U	FRN030F1S-4U
40	FRN040F1S-2U	FRN040F1S-4U
50	FRN050F1S-2U	FRN050F1S-4U
60	FRN060F1S-2U	FRN060F1S-4U
75	FRN075F1S-2U	FRN075F1S-4U
100	FRN100F1S-2U	FRN100F1S-4U
125	FRN125F1S-2U	FRN125F1S-4U
150		FRN150F1S-4U
200		FRN200F1S-4U
250		FRN250F1S-4U
300		FRN300F1S-4U
350		FRN350F1S-4U
400		FRN400F1S-4U
450		FRN450F1S-4U
500		FRN500F1S-4U
600		FRN600F1S-4U
700		FRN700F1S-4U
800		FRN800F1S-4U
900		FRN900F1S-4U

## How to read the model number

**FRN 007 F 1 S - 2 U**

Code	Series name
FRN	FRENIC series

Code	Applicable motor rating [HP]
001	1HP
002	2HP
003	3HP
005	5HP
007	7.5HP
010	10HP
015	15HP
020	20HP
?	?
700	700HP
800	800HP
900	900HP

Code	Application range
F	Fans and pumps (For variable torque load)

Code	Developed inverter series
1	1

Code	Version/Manual
U	USA/English

Code	Input power supply
2	3-phase 208V
4	3-phase 460V

Code	Structure
S	Standard type(IP20/IP00)

**Caution** Use the contents of this catalog only for selecting product types and models. When using a product, read the Instruction Manual beforehand to use the product correctly.

## ■ Three-phase 208V

Item		Specifications																
Type (FRN -- F1S-2U)		001	002	003	005	007	010	015	020	025	030	040	050	060	075	100	125	
Nominal applied motor [HP]		*1	1	2	3	5	7.5	10	15	20	25	30	40	50	60	75	100	125
Output ratings	Rated capacity [kVA]	*2	1.6	2.7	3.8	6.0	9.0	11	16	21	27	31	41	51	60	76	98	123
	Rated voltage [V]	*3	Three-phase, 200V to 240V (With AVR function)										Three-phase, 200V to 230V (With AVR function)					
	Rated current [A]	*4	4.6	7.5	10.6	16.7	25	31	47	60	75	88	114	143	169	211	273	343
	Overload capability		120% of rated current for 1min.															
	Rated frequency		50, 60 Hz															
Input ratings	Phases, voltage, frequency	Main power supply	Three-phase, 200 to 240V, 50/60Hz										Three-phase, 200 to 220V, 50Hz Three-phase, 200 to 230V, 60Hz					
		Auxiliary control power input	Single-phase, 200 to 240V, 50/60Hz										Single-phase, 200 to 220V, 50Hz Single-phase, 200 to 230V, 60Hz					
		Auxiliary fan power input	*5	None										Single-phase, 200 to 220V, 50Hz Single-phase, 200 to 230V, 60Hz				
	Voltage/frequency variations		Voltage: +10 to -15% (Voltage unbalance 2% or less) *9, Frequency: +5 to -5%															
	Rated current [A]	*6	(with DCR)	3.1	5.8	8.7	14.5	20.6	27.5	41.3	55.1	68.8	82.6	109	134	160	199	270
		(without DCR)	5.1	9.1	12.9	21.5	30.8	40.8	59.4	76.6	94.0	110	144	179	215	—	—	—
Required power supply capacity [kVA]	*7		1.2	2.2	3.2	5.3	7.5	10	15	20	25	30	40	49	58	72	98	120
Braking	Torque [%]	*8	20.0										10 to 15					
	DC injection braking		Starting frequency: 0.0 to 60.0Hz, Braking time: 0.0 to 30.0s, Braking level: 0 to 60%															
DC reactor (DCR)		Option												Standard				
Applicable safety standards		UL508C, C22.2 No.14, EN50178-1997																
Enclosure (IEC60529)		IP20, UL open type										IP00, UL open type						
Cooling method		Natural cooling	Fan cooling															
Mass [lbs(kg)]			7.1 (3.2)	7.3 (3.3)	7.3 (3.3)	7.5 (3.4)	13 (5.8)	13 (6.0)	15 (6.9)	21 (9.7)	21 (9.7)	25 (11.5)	51 (23)	73 (33)	75 (34)	90 (41)	90 (41)	265 (120)

\*1 Standard 4-pole motor

\*2 Rated capacity is calculated by assuming the output rated voltage as 208V for three-phase 208V.

\*3 Output voltage cannot exceed the power supply voltage.

\*4 An excessively low setting of the carrier frequency may result in the higher motor temperature or tripping of the inverter by its overcurrent limiter setting. Lower the continuous load or maximum load instead. (When setting the carrier frequency (F26) to 1kHz, reduce the load to 80% of its rating.)

\*5 Use [R1,T1] terminals for driving AC cooling fans of an inverter powered by the DC link bus, such as by a high power factor PWM converter. (In ordinary operation, the terminals are not used.)

\*6 Calculated under Fuji-specified conditions.

\*7 Obtained when a DC reactor (DCR) is used.

\*8 Average braking torque (Varies with the efficiency of the motor.)

\*9 Voltage unbalance (%) =  $\frac{\text{Max. voltage (V)} - \text{Min. voltage (V)}}{\text{Three-phase average voltage (V)}} \times 67$  (IEC61800-3 (5.2.3))

If this value is 2 to 3%, use an AC reactor (ACR).

## ■ Three-phase 460V

### ●1 to 75HP

Item		Specifications														
Type (FRN _ _ _ F1S-4U)		001	002	003	005	007	010	015	020	025	030	040	050	060	075	
Nominal applied motor [HP]		*1	1	2	3	5	7.5	10	15	20	25	30	40	50	60	75
Output ratings	Rated capacity [kVA]	*2	1.9	2.9	4.3	7.1	9.9	13	18	23	29	35	47	57	67	83
	Rated voltage [V]	*3	Three-phase, 380 to 480V (With AVR function)													
	Rated current [A]	*4	2.5	3.7	5.5	9.0	12.5	16.5	23	30	37	44	59	72	85	105
	Overload capability		120% of rated current for 1min.													
	Rated frequency		50, 60 Hz													
Input ratings	Phases, voltage, frequency	Main power supply	Three-phase, 380 to 480V, 50/60Hz										Three-phase, 380 to 440V,50Hz Three-phase, 380 to 480V,60Hz			
		Auxiliary control power input	Single-phase, 380 to 480V, 50/60Hz										Single-phase, 380 to 440V/50Hz Single-phase, 380 to 480V/60Hz			
		Auxiliary fan power input	*5	None										Single-phase, 380 to 440V/50Hz Single-phase, 380 to 480V/60Hz		
	Voltage/frequency variations		Voltage: +10 to -15% (Voltage unbalance 2% or less) *9, Frequency: +5 to -5%													
Rated current [A]	*6	(with DCR)	1.3	2.5	3.8	6.2	8.9	11.8	17.7	23.7	29.6	35.5	46.8	57.0	68.4	85.7
		(without DCR)	2.5	4.8	6.9	10.8	14.5	19.1	27.7	36.0	43.6	50.9	64.0	78.5	93.7	118
Required power supply capacity [kVA]	*7	1.1	2.0	3.1	5.0	7.1	10	15	19	24	29	38	46	55	69	
Braking	Torque [%]	*8	20										10 to 15			
	DC injection braking		Starting frequency: 0.0 to 60.0Hz, Braking time:0.0 to 30.0s, Braking level: 0 to 60%													
DC reactor (DCR)			Option													
Applicable safety standards			UL508C, C22.2 No.14, EN50178-1997													
Enclosure (IEC60529)			IP20, UL open type										IP00, UL open type			
Cooling method			Natural cooling							Fan cooling						
Mass [lbs(kg)]			6.8 (3.1)	7.1 (3.2)	7.3 (3.3)	7.5 (3.4)	7.5 (3.4)	13 (6.0)	13 (6.0)	15 (6.9)	22 (9.9)	22 (9.9)	25 (11.5)	51 (23)	53 (24)	73 (33)

### 100 to 900HP

Item		Specifications														
Type (FRN _ _ _ F1S-4U)		100	125	150	200	250	300	350	400	450	500	600	700	800	900	
Nominal applied motor [HP]		*1	100	125	150	200	250	300	350	400	450	500	600	700	800	900
Output ratings	Rated capacity [kVA]	*2	110	133	161	191	240	286	330	380	414	517	589	669	764	828
	Rated voltage [V]	*3	Three-phase, 380 to 480V (With AVR function)													
	Rated current [A]	*4	139	168	203	240	302	360	415	477	520	650	740	840	960	1040
	Overload capability		120% of rated current for 1min.													
	Rated frequency		50, 60 Hz													
Input ratings	Phases, voltage, frequency	Main power supply	Three-phase, 380 to 440V, 50Hz Three-phase, 380 to 480V, 60Hz													
		Auxiliary control power input	Single-phase, 380 to 440V/50Hz Single-phase, 380 to 480V/60Hz													
		Auxiliary fan power input	*5	Single-phase, 380 to 440V/50Hz Single-phase, 380 to 480V/60Hz												
	Voltage/frequency variations		Voltage: +10 to -15% (Voltage unbalance 2% or less) *9, Frequency: +5% to -5%													
Rated current [A]	*6	(with DCR)	113	140	169	222	275	330	382	440	495	545	652	756	869	981
		(without DCR)	—	—	—	—	—	—	—	—	—	—	—	—	—	—
Required power supply capacity [kVA]	*7	91	112	135	177	220	263	305	351	395	435	520	603	693	782	
Braking	Torque [%]	*8	10 to 15													
	DC injection braking		Starting frequency: 0.0 to 60.0Hz, Braking time:0.0 to 30.0s, Braking level: 0 to 60%													
DC reactor (DCR)			Standard													
Applicable safety standards			UL508C, C22.2 No.14, EN50178-1997										UL508C, C22.2 No.14			
Enclosure (IEC60529)			IP00, UL open type													
Cooling method			Fan cooling													
Mass [lbs(kg)]			75 (34)	93 (42)	99 (45)	139 (63)	212 (96)	212 (96)	216 (98)	357 (162)	357 (162)	529 (240)	529 (240)	783 (355)	794 (360)	794 (360)

\*1 Standard 4-pole motor

\*2 Rated capacity is calculated by assuming the output rated voltage as 460V for three-phase 460V.

\*3 Output voltage cannot exceed the power supply voltage.

\*4 An excessively low setting of the carrier frequency may result in the higher motor temperature or tripping of the inverter by its overcurrent limiter setting. Lower the continuous load or maximum load instead. (When setting the carrier frequency (F26) to 1kHz, reduce the load to 80% of its rating.)

\*5 Use [R1,T1] terminals for driving AC cooling fans of an inverter powered by the DC link bus, such as by a high power factor PWM converter. (In ordinary operation, the terminals are not used.)

\*6 Calculated under Fuji-specified conditions.

\*7 Obtained when a DC reactor (DCR) is used.

\*8 Average braking torque (Varies with the efficiency of the motor.)

\*9 Voltage unbalance (%) =  $\frac{\text{Max. voltage (V)} - \text{Min. voltage (V)}}{\text{Three-phase average voltage (V)}} \times 67$  (IEC61800-3(5.2.3))

If this value is 2 to 3%, use an AC reactor (ACR).

# External Dimensions

## Inverter Outline (5HP for 208V, 7.5HP for 460V or smaller)

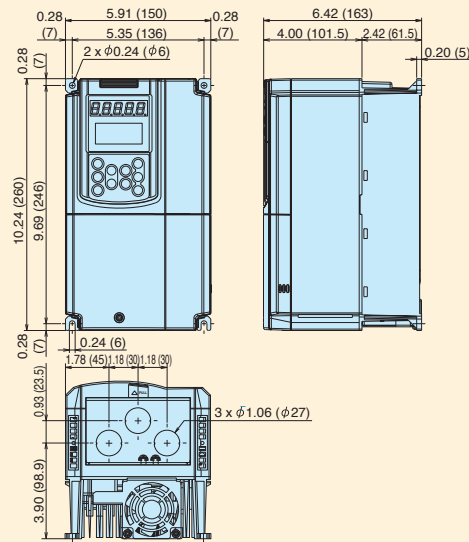

Unit:inch (mm)

Power supply voltage	Type
Three-phase 208V	FRN001F1S-2U
	FRN002F1S-2U
	FRN003F1S-2U
	FRN005F1S-2U
Three-phase 460V	FRN001F1S-4U
	FRN002F1S-4U
	FRN003F1S-4U
	FRN005F1S-4U
	FRN007F1S-4U

## Inverter Outline (7.5HP to 30HP for 208V, 10HP to 40HP for 460V)

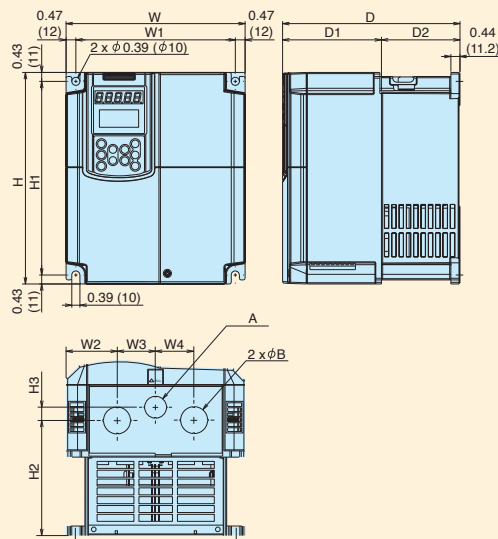

Unit:inch (mm)

Power supply voltage	Type	Dimensions [inch (mm)]														
		W	W1	W2	W3	W4	H	H1	H2	H3	D	D1	D2	φA	φB	
Three-phase 208V	FRN007F1S-2U															
	FRN010F1S-2U	8.66 (220)	7.72 (196)	2.50 (63.5)	1.83 (46.5)	1.83 (46.5)	10.2 (260)	9.37 (238)	5.58 (141.7)	0.63 (16)	8.46 (215)	4.67 (118.5)	3.80 (96.5)	1.06 (27)	1.34 (34)	
	FRN015F1S-2U															
	FRN020F1S-2U	9.84 (250)	8.90 (226)	2.64 (67)	2.28 (58)	2.28 (58)	15.7 (400)	14.9 (378)	6.54 (166.2)	0.08 (2)		3.35 (85)	5.12 (130)	1.34 (34)	1.65 (42)	
	FRN030F1S-2U															
Three-phase 460V	FRN010F1S-4U															
	FRN015F1S-4U	8.66 (220)	7.72 (196)	2.50 (63.5)	1.83 (46.5)	1.83 (46.5)	10.2 (260)	9.37 (238)	5.58 (141.7)	0.63 (16)	8.46 (215)	4.67 (118.5)	3.80 (96.5)	1.06 (27)	1.34 (34)	
	FRN020F1S-4U															
	FRN025F1S-4U	9.84 (250)	8.90 (226)	2.64 (67)	2.28 (58)	2.28 (58)	15.7 (400)	14.9 (378)	6.54 (166.2)	0.08 (2)		3.35 (85)	5.12 (130)	1.34 (34)	1.65 (42)	
	FRN030F1S-4U															
	FRN040F1S-4U															

## Inverter Outline 40HP to 125HP for 208V, 50HP to 900HP for 460V

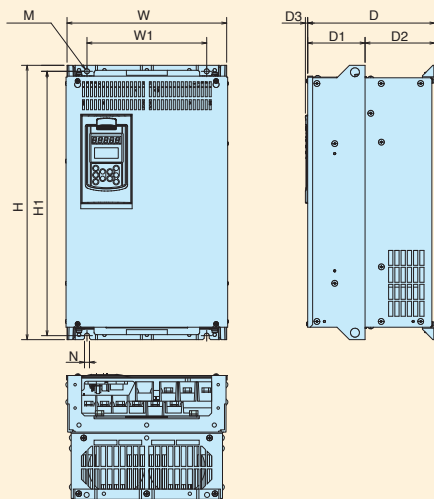

Unit:inch (mm)

Power supply voltage	Type	Dimensions [inch (mm)]										
		W	W1	H	H1	D	D1	D2	D3	M	N	
Three-phase 208V	FRN040F1S-2U	12.6 (320)	9.45 (240)	21.7 (550)	20.9 (530)	10.0 (255)		5.51 (140)				
	FRN050F1S-2U			24.2 (615)	23.4 (595)	10.6 (270)	4.53 (115)	6.10 (155)	0.18 (4.5)	2xφ0.39 (2xφ10)	0.39 (10)	
	FRN060F1S-2U	13.98 (355)	10.83 (275)									
	FRN075F1S-2U			29.1 (740)	28.3 (720)							
	FRN100F1S-2U	26.77 (680)	22.83 (580)	34.6 (880)	33.5 (850)	15.6 (395)	10.04 (255)	5.51 (140)	0.24 (6)	3xφ0.59 (3xφ15)	0.59 (15)	
Three-phase 460V	FRN050F1S-4U	12.60 (320)	9.45 (240)	21.7 (550)	20.9 (530)	10.0 (255)		5.51 (140)				
	FRN060F1S-4U					10.6 (270)	4.53 (115)	6.10 (155)	0.18 (4.5)	2xφ0.39 (2xφ10)	0.39 (10)	
	FRN075F1S-4U											
	FRN100F1S-4U	13.98 (355)	10.83 (275)	24.2 (615)	23.4 (595)	10.6 (270)	11.8 (300)	5.71 (145)	6.10 (155)			
	FRN125F1S-4U			29.1 (740)	28.3 (720)							
	FRN150F1S-4U			29.1 (740)	28.0 (710)	12.4 (315)	5.31 (135)	7.09 (180)	0.24 (6)	2xφ0.39 (2xφ10)	0.39 (10)	
	FRN200F1S-4U	20.9 (530)	16.9 (430)	39.4 (1000)	38.2 (970)	14.2 (360)	7.09 (180)	7.09 (180)				
	FRN250F1S-4U											
	FRN300F1S-4U											
	FRN350F1S-4U											
	FRN400F1S-4U			39.4 (1000)	38.2 (970)	15 (380)	7.87 (200)					
	FRN450F1S-4U	26.77 (680)	22.83 (580)									
	FRN500F1S-4U											
	FRN600F1S-4U											
FRN700F1S-4U			55.1 (1400)	53.9 (1370)	17.3 (440)	10.2 v (260)						
FRN800F1S-4U	34.65 (880)	30.71 (780)										
FRN900F1S-4U												

### Multi-function keypad (TP-G1W-J1) (standard accessory)

Unit:inch (mm)

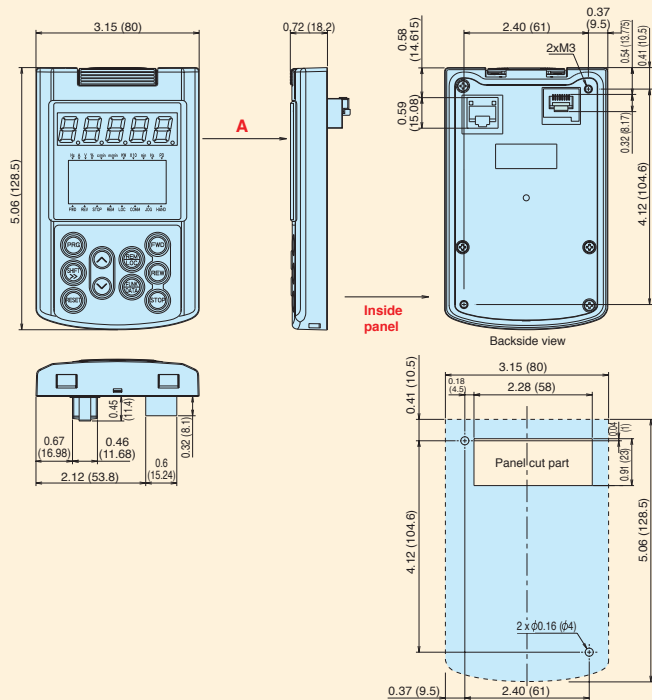

Dimensions of panel cutting (viewed from "A")

■ NEMA1 kit (NEMA1-□□□F1-□□)

NEMA1 kit, when fitted to the FRENIC-Eco series, protects the inverter body with the structure the conforms to the NEMA1 standard (approved as UL TYPE1). Using NEMA1 kit, ambient temperature is -10 to 40°C (14 to 104F)

• Combination between F1S Series Inverter and NEMA1 Cover

Optional type	Inverter type	Dimensions [inch(mm)]								Outside figure
	FECO A	W	H	D	A	B	C	E	Conduit dia × pcs	
NEMA1-5.5F1-24	FRN001 to 005F1S-2U	5.91 (150)	10.24 (260)	6.42 (163)	—	—	—	—	φ 1.06(27) × 3	A
	FRN001 to 007F1S-4U									
NEMA1-11F1-24	FRN007 to 010F1S-2U	8.66 (220)	10.24 (260)	8.47 (215)	—	—	—	—	φ 1.06(27) × 1 φ 1.34(34) × 2	A
	FRN010 to 015F1S-4U									
NEMA1-15F1-24	FRN015F1S-2U	8.66 (220)	10.24 (260)	8.47 (215)	1.18 (30)	3.57 (90.7)	6.55 (166.4)	—	φ 1.34(34) × 1 φ 1.65(42) × 2	B
	FRN020F1S-4U									
NEMA1-22F1-24	FRN020 to 025F1S-2U	9.84 (250)	15.75 (400)	8.47 (215)	—	—	—	—	φ 1.34(34) × 1 φ 1.65(42) × 2	A
	FRN025 to 030F1S-4U									
NEMA1-30F1-24	FRN030F1S-2U	9.84 (250)	15.75 (400)	8.47 (215)	3.94 (100)	7.21 (183.2)	8.07 (205)	—	φ 1.34(34) × 1 φ 1.89(48) × 2	C
	FRN040F1S-4U									
NEMA1-45F1-24	FRN040F1S-2U	12.60 (320)	21.65 (550)	10.04 (255)	4.92 (125)	4.35 (110.5)	12.73 (323.4)	5.90 (150)	φ 1.89(48) × 1 φ 2.52(64) × 3	D
	FRN050 to 060F1S-4U									
NEMA1-75F1-2	FRN050 to 60F1S-2U	13.98 (355)	24.21 (615)	10.63 (270)	7.48 (190)	4.35 (110.5)	14.11 (358.4)	8.47 (215)	φ 1.89(48) × 1 φ 3.03(77) × 3	D
	FRN075 to 100F1S-2U	13.98 (355)	29.13 (740)	10.63 (270)						
NEMA1-75F1-4	FRN075F1S-4U	13.98 (355)	21.65 (550)	10.63 (270)	3.54 (90)	4.35 (110.5)	14.11 (358.4)	4.53 (115)	φ 1.89(48) × 1 φ 2.52(64) × 3	D
	FRN100F1S-4U	13.98 (355)	24.21 (615)	10.63 (270)						
NEMA1-110F1-4	FRN125 to 150F1S-4U	13.98 (355)	29.13 (740)	11.81 (300)	3.74 (95)	5.53 (140.5)	14.11 (358.4)	4.72 (120)	φ 1.89(48) × 1 φ 2.52(64) × 3	D
NEMA1-132F1-4	FRN200F1S-4U	20.87 (530)	29.13 (740)	12.40 (315)	3.74 (95)	5.24 (133)	21.00 (533.4)	5.12 (130)	φ 1.89(48) × 1 φ 2.52(64) × 3	D
NEMA1-110F1-2	FRN125F1S-2U	26.77 (680)	34.65 (880)	15.55 (395)	14.02 (356)	10.04 (255)	26.90 (683.2)	15.16 (385)	φ 1.89(48) × 1 φ 3.54(90) × 3	D
NEMA1-220F1-4	FRN250 to 350F1S-4U	20.87 (530)	39.37 (1000)	14.17 (360)	5.12 (130)	7.01 (178)	21.00 (533.4)	6.50 (165)	φ 1.89(48) × 1 φ 4.33(110) × 3	D
NEMA1-280F1-4	FRN400 to 450F1S-4U	26.77 (680)	39.37 (1000)	14.96 (380)	9.65 (245)	5.58 (141.6)	26.94 (684.2)	11.02 (280)	φ 1.89(48) × 1 φ 4.33(110) × 3	D
NEMA1-400F1-4	FRN500 to 60F1S-40	26.77 (680)	55.12 (1400)	17.32 (440)	9.95 (240)	7.94 (201.6)	26.94 (684.2)	10.83 (275)	φ 1.89(48) × 1 φ 5.63(14) × 3	D
NEMA1-560F1-4	FRN700 to 900F1S-40	34.65 (880)	55.12 (1400)	17.32 (440)	9.95 (240)	7.94 (201.6)	34.81 (884.2)	10.83 (275)	φ 1.89(48) × 1 φ 5.63(14) × 3	D

Fig. A

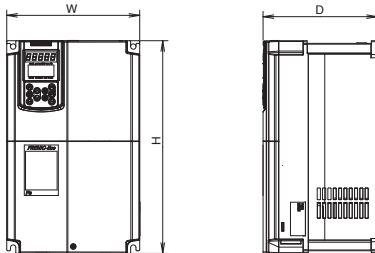

Fig. B

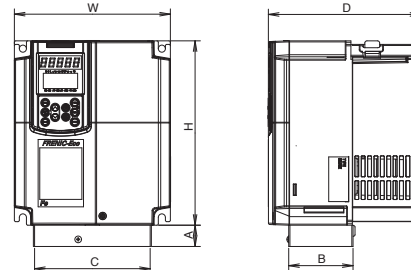

Fig. C

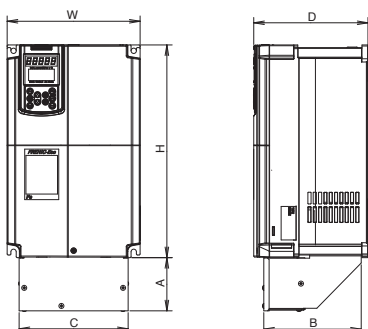
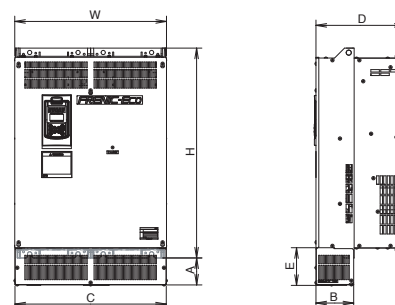

Fig. D





## Operator-friendly features

### A multi-function keypad is available as standard.

- Includes an easier to see LCD with backlight.
- It has a large 7-segment, 5-digit LED display.
- It is possible to add and delete quick setup items.
- A remote/local key has been added.
- Copying up to 3 sets of data is possible.



### A keypad that enables remote operation is standard equipment.

The standard keypad has a decorative cover on the bottom that can be slid sideways and removed. A LAN cable can be used to connect the panel, making it possible to use it as a remote operation keypad.



### Personal computer loader software



Store, manage and verify settings data.



Monitoring



Real-time tracing



Maintenance Information



Operation



## Network compatibility

- RS-485 communication is standard. Selectable from Modbus-RTU, Metasys-N2, FLN P1.
- It is compatible with the following networks by inserting the option card.

- Device Net
- LonWORKS Network
- PROFIBUS-DP
- BACnet



## Global compatibility

European Union  
EC Regulation (CE mark)



North America/Canada  
UL Standards (cUL certified)



- Compliance with standards
- Sink/source switchable
- Wide voltage range
- Multi-function keypad displaying multiple languages (Japanese, English, German, French, Spanish, Italian)



## NOTES

### When running general-purpose motors

- **Driving a 460V general-purpose motor**  
When driving a 460V general-purpose motor with an inverter using extremely long cables, damage to the insulation of the motor may occur. Use an output circuit filter (OFL) if necessary after checking with the motor manufacturer. Fuji's motors do not require the use of output circuit filters because of their reinforced insulation.
- **Torque characteristics and temperature rise**  
When the inverter is used to run a general-purpose motor, the temperature of the motor becomes higher than when it is operated using a commercial power supply. In the low-speed range, the cooling effect will be weakened, so decrease the output torque of the motor. If constant torque is required in the low-speed range, use a Fuji inverter motor or a motor equipped with an externally powered ventilating fan.
- **Vibration**  
When the motor is mounted to a machine, resonance may be caused by the natural frequencies, including that of the machine. Operation of a 2-pole motor at 60Hz or more may cause abnormal vibration.  
\* Study use of tier coupling or dampening rubber.  
\* It is also recommended to use the inverter jump frequency control to avoid resonance points.
- **Noise**  
When an inverter is used with a general-purpose motor, the motor noise level is higher than that with a commercial power supply. To reduce noise, raise carrier frequency of the inverter. High-speed operation at 60Hz or more can also result in more noise.

### When running special motors

- **High-speed motors**  
When driving a high-speed motor while setting the frequency higher than 120Hz, test the combination with another motor to confirm the safety of high-speed motors.
- **Explosion-proof motors**  
When driving an explosion-proof motor with an inverter, use a combination of a motor and an inverter that has been approved in advance.
- **Submersible motors and pumps**  
These motors have a larger rated current than general-purpose motors. Select an inverter whose rated output current is greater than that of the motor.  
These motors differ from general-purpose motors in thermal characteristics. Set a low value in the thermal time constant of the motor when setting the electronic thermal facility.
- **Brake motors**  
For motors equipped with parallel-connected brakes, their braking power must be supplied from the primary circuit (commercial power supply). If the brake power is connected to the inverter power output circuit (secondary circuit) by mistake, problems may occur.  
Do not use inverters for driving motors equipped with series-connected brakes.
- **Geared motors**  
If the power transmission mechanism uses an oil-lubricated gearbox or speed changer/reducer,

then continuous motor operation at low speed may cause poor lubrication. Avoid such operation.

- **Synchronous motors**  
It is necessary to use software suitable for this motor type. Contact Fuji for details.
- **Single-phase motors**  
Single-phase motors are not suitable for inverter-driven variable speed operation. Use three-phase motors.  
\* Even if a single-phase power supply is available, use a three-phase motor as the inverter provides three-phase output.

### Environmental conditions

- **Installation location**  
Use the inverter in a location with an ambient temperature range of -10 to 50°C (14 to 122°F). The inverter and braking resistor surfaces become hot under certain operating conditions. Install the inverter on nonflammable material such as metal. Ensure that the installation location meets the environmental conditions specified in "Environment" in inverter specifications.

### Combination with peripheral devices

- **Installing a molded case circuit breaker (MCCB)**  
Install a recommended molded case circuit breaker (MCCB) or a ground-fault circuit interrupter (GFCI) in the primary circuit of each inverter to protect the wiring. Ensure that the circuit breaker capacity is equivalent to or lower than the recommended capacity.
- **Installing a magnetic contactor (MC) in the output (secondary) circuit**  
If a magnetic contactor (MC) is mounted in the inverter's secondary circuit for switching the motor to commercial power or for any other purpose, ensure that both the inverter and the motor are fully stopped before you turn the MC on or off. Remove the surge killer integrated with the MC.
- **Installing a magnetic contactor (MC) in the input (primary) circuit**  
Do not turn the magnetic contactor (MC) in the primary circuit on or off more than once an hour as an inverter fault may result. If frequent starts or stops are required during motor operation, use FWD/REV signals.
- **Protecting the motor**  
The electronic thermal facility of the inverter can protect the motor. The operation level and the motor type (general-purpose motor, inverter motor) should be set. For high-speed motors or water-cooled motors, set a small value for the thermal time constant to protect the motor.  
If you connect the motor thermal relay to the motor with a long cable, a high-frequency current may flow into the wiring stray capacitance. This may cause the relay to trip at a current lower than the set value for the thermal relay. If this happens, lower the carrier frequency or use the output circuit filter.
- **Discontinuance of power-factor correcting capacitor**  
Do not mount power factor correcting capacitors in the inverter (primary) circuit. (Use the DC REACTOR to improve the inverter power factor.) Do not use power factor correcting capacitors in the

inverter output circuit (secondary). An overcurrent trip will occur, disabling motor operation.

- **Discontinuance of surge killer**  
Do not mount surge killers in the inverter output (secondary) circuit.
- **Reducing noise**  
Use of a filter and shielded wires are typical measures against noise to ensure that EMC Directives are met.
- **Measures against surge currents**  
If an overvoltage trip occurs while the inverter is stopped or operated under a light load, it is assumed that the surge current is generated by open/close of the phase-advancing capacitor in the power system.  
We recommend connecting a DC REACTOR to the inverter.
- **Megger test**  
When checking the insulation resistance of the inverter, use a 500V megger and follow the instructions contained in the Instruction Manual.

### Wiring

- **Wiring distance of control circuit**  
When performing remote operation, use the twisted shield wire and limit the distance between the inverter and the control box to 65.6ft (20m).
- **Wiring length between inverter and motor**  
If long wiring is used between the inverter and the motor, the inverter will overheat or trip as a result of overcurrent (high-frequency current flowing into the stray capacitance) in the wires connected to the phases. Ensure that the wiring is shorter than 164ft (50m). If this length must be exceeded, lower the carrier frequency or mount an output circuit filter.
- **Wiring size**  
Select cables with a sufficient capacity by referring to the current value or recommended wire size.
- **Wiring type**  
Do not use multicore cables that are normally used for connecting several inverters and motors.
- **Grounding**  
Securely ground the inverter using the grounding terminal.

### Selecting inverter capacity

- **Driving general-purpose motor**  
Select an inverter according to the applicable motor ratings listed in the standard specifications table for the inverter. When high starting torque is required or quick acceleration or deceleration is required, select an inverter with a capacity one size greater than the standard.
- **Driving special motors**  
Select an inverter that meets the following condition:  
Inverter rated current > Motor rated current.

### Transportation and storage

When transporting or storing inverters, follow the procedures and select locations that meet the environmental conditions that agree with the inverter specifications.

# Fuji Electric Corp. of America

www.americas.fujielectric.com

47520 Westinghouse Drive Fremont, CA 94539, U.S.A.

Tel. 510-440-1060 Fax. 510-440-1063

Printed on recycled paper

Information in this catalog is subject to change without notice.