

Option Attachment "OPC-E2-ADP1"

⚠ CAUTION

- | |
|---------------------------------------------------------------------------------------------------------------------------------------------------------------------------------------------------------------------------------------------------------------------------------------------------------------------------------------------------------------------------------------------------------------------------------------------------------------------------------------------------------------------------------------------------|
| <ul style="list-style-type: none">- Please read and ensure a proper understanding of this manual before installing, connecting (wiring), operating, or conducting maintenance and inspection of the interface option.- Improper handling might result in incorrect operation, a short life, or even a failure of this product as well as the motor.- Deliver this manual to the end user of this product. The end user should store this instruction manual safely until such time as the product is disposed of. |
|---------------------------------------------------------------------------------------------------------------------------------------------------------------------------------------------------------------------------------------------------------------------------------------------------------------------------------------------------------------------------------------------------------------------------------------------------------------------------------------------------------------------------------------------------|

Thank you for purchasing the option attachment "OPC-E2-ADP1".
 The use of this option attachment allows the FRENIC-Ace series to be equipped with option cards (sold separately).

1. Product Check

Please check the following before using the product.

- (4) Check the model on the nameplate and ensure that the product is the same as that ordered.
 - (5) Ensure that the package contains both the attachment and accessories.
 - (6) Ensure that neither the attachment nor accessories have suffered damage such as breakage or denting during transport.
-  Refer to the "1.1 Product configuration" diagram on the right for details of the nameplate attachment location and accessories.

If anything is out of place, or the product appears to be defective, contact your dealer or nearest Fuji sales office.

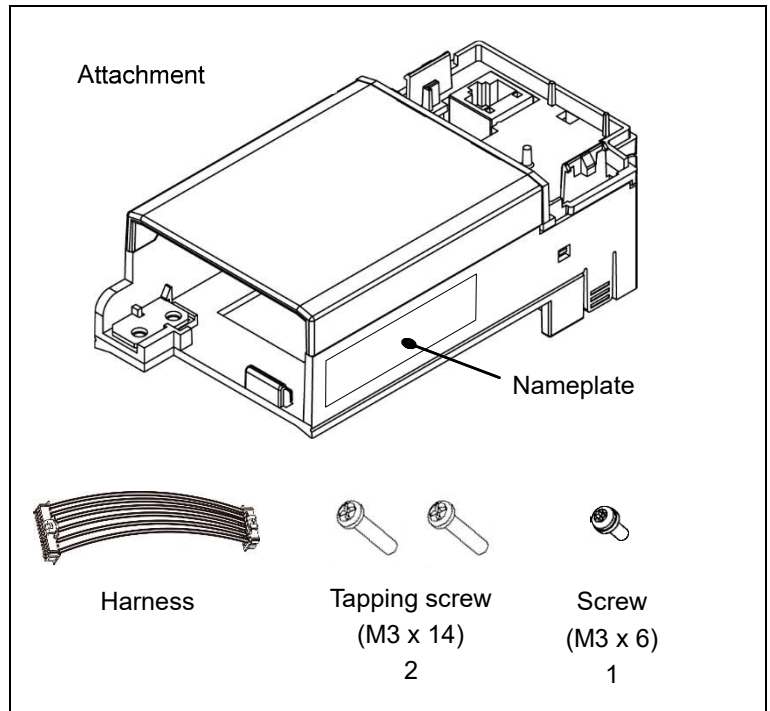

1.1 Product configuration

2. Specifications

The applicable scope for this product is as follows.

(1) Applicable models

Series name	Inverter capacity
FRENIC-Ace	FRN0.1E2□-□□□ to FRN15E2□-□□□ FRN0001E2□-2□□ to FRN0069E2□-2□□ FRN0002E2□-4□□ to FRN0044E2□-4□□ FRN0001E2□-7□□ to FRN0012E2□-7□□

(2) No. of installable option cards: 1

3. Installation Method

⚠ WARNING

Please wait at least 5 minutes after the inverter power has been turned OFF before attempting installation and wiring.

Also ensure that the touch panel LEDs are OFF, and use a tester to confirm that the DC intermediate circuit voltage across main circuit terminals P(+) and N(-) has dropped to a stable value (+25 VDC or lower).

Risk of electric shock

 Note Wire the inverter main circuit terminals and control circuit terminals before installing this attachment.

- Step 1** First, wire the inverter main circuit terminals and control circuit terminals.
- Step 2** Follow the installation procedure on the next page to install the attachment.
- Step 3** Install the option card.
- Step 4** Wire the option card to the attachment ground wire and option card terminals.

 Note Secure the wiring near the inverter to prevent the weight of the wiring being applied to the option card.

Installation procedure [Example using option card OPC-DIO]

- (1)** Remove the bottom cover. **(2)** Open the top cover.

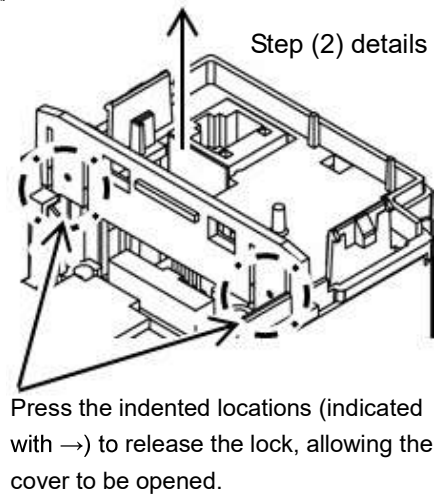
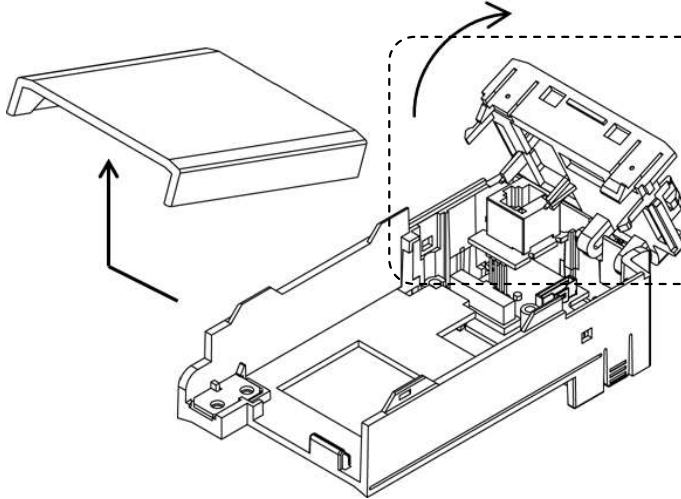

- (3)** Remove the touch panel.

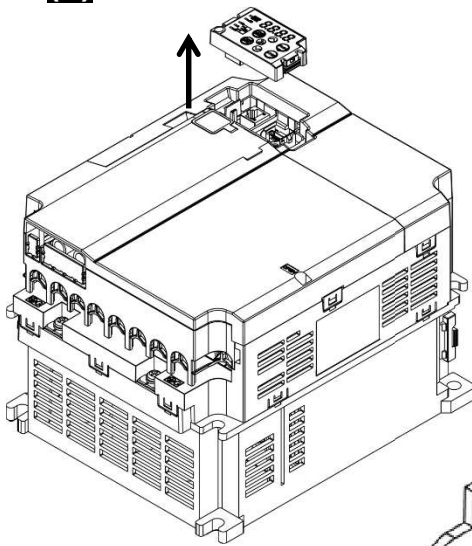

- (5)** Pass the harness through to the inside of the attachment.

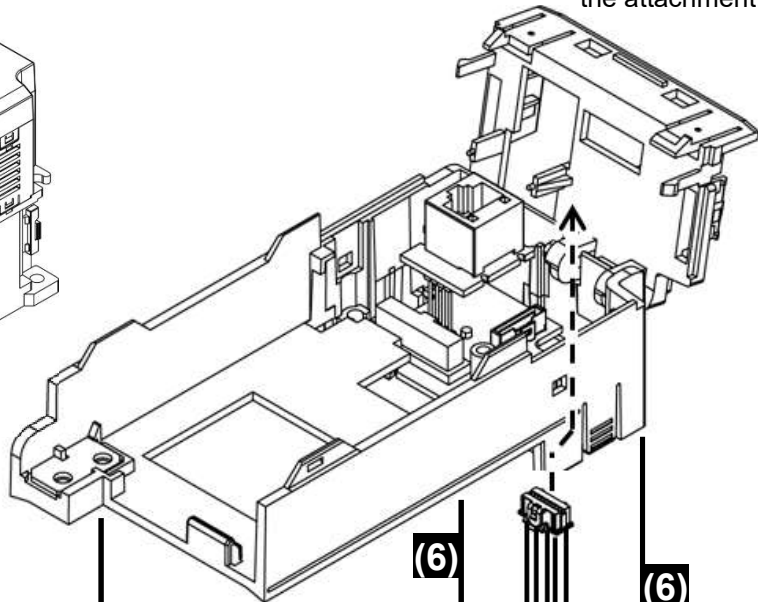

- (7)** Connect the connector on the opposite end of the harness to the attachment connector.

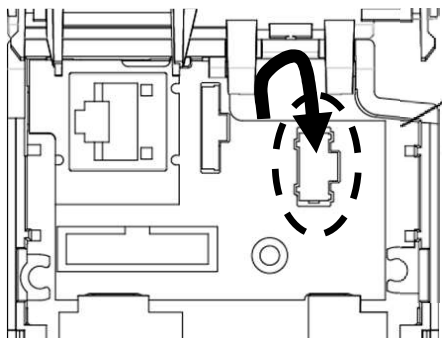

- (6)** Attach the attachment to the inverter.

- (4)** Connect the harness to the inverter connector (larger side of connector).

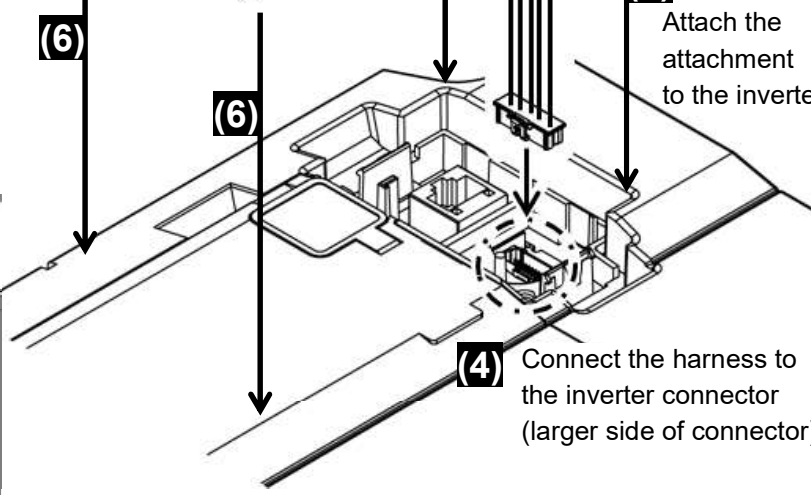

Note Ensure that all connectors have been inserted fully and are locked.

- (8)** Tighten with tapping screws. *1
Tightening torque: 0.25 N·m *2

- *1 The attachment will be temporarily secured with the clips on the case, however, it must be secured properly with the tapping screws before performing operation.
*2 The tapping screws may be deformed or damaged if tightened with more than the specified amount of torque.

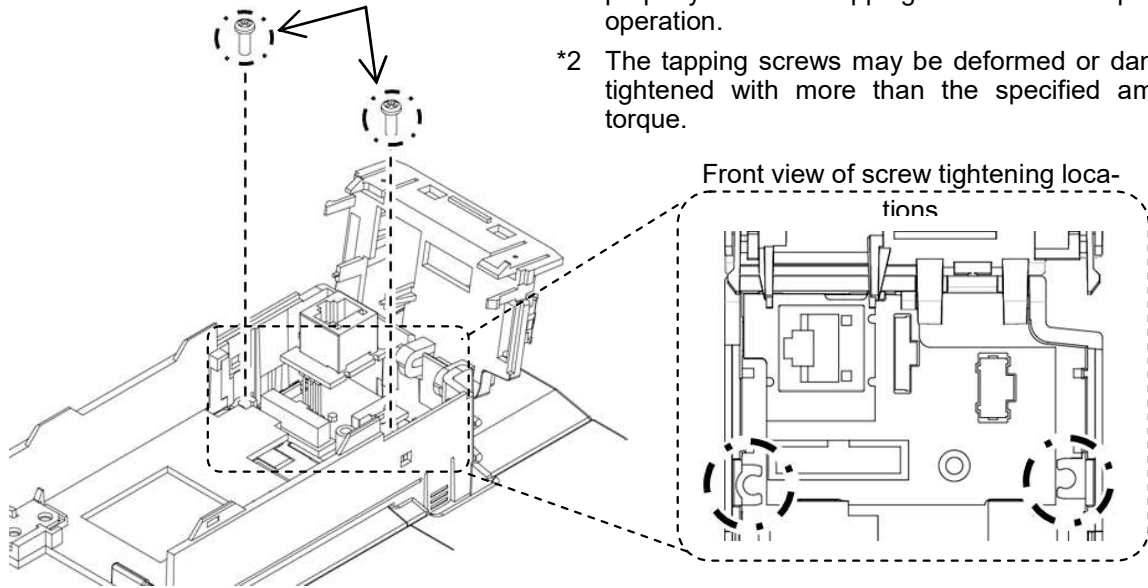

- (9)** Align the option card with the protrusion.

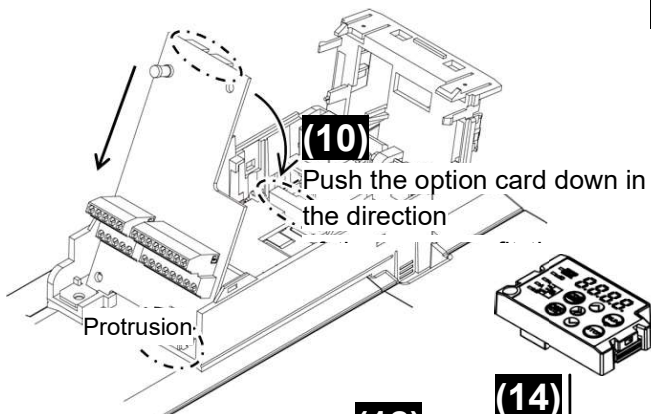

- (11)** Tighten the board securing screws. (screws provided with option card) Tightening torque: 0.7 N·m *2

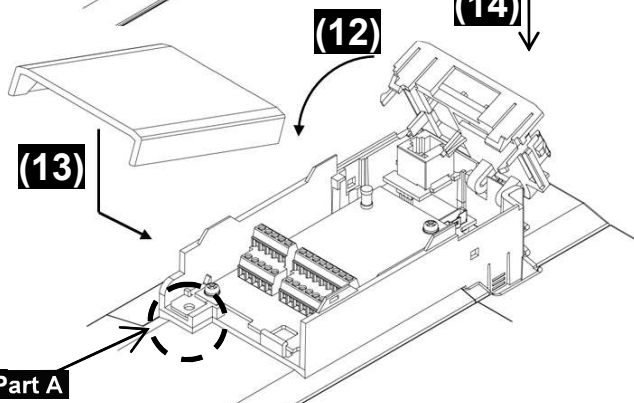
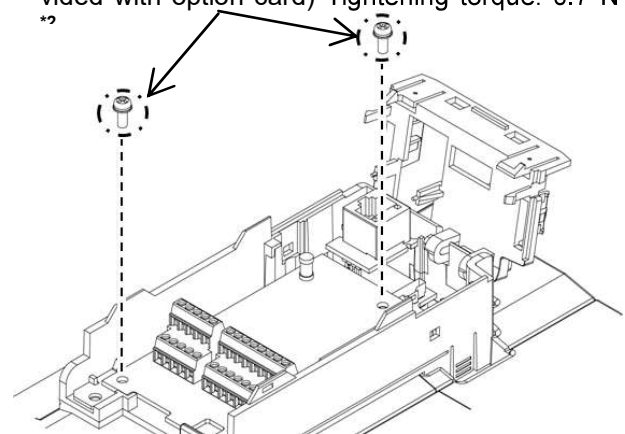

- (15)** Attachment installation complete

Use the screw (M3 x 6) provided to connect the ground wire to **Part A**.
Tightening torque: 0.7 N·m *2 Recommended ground wire size: AWG 20 to 16 (0.5 to 1.5 mm²)

Note If removing the attachment, always disconnect one side of the harness connector beforehand.

Note Always connect the attachment ground wire to the inverter ground to ground the inverter also.

Fuji Electric Co., Ltd.

Gate City Ohsaki, East Tower, 11-2, Osaki 1-chome, Shinagawa-ku, Tokyo, 141-0032, Japan
Phone: +81 3 5435 7058 Fax: +81 3 5435 7420

URL <http://www.fujielectric.com/>