

# RS-485 Communications Card "OPC-E2-RS"

Thank you for purchasing this RS-485 communications card "OPC-E2-RS." Installing this card to your inverter enables RS-485 communication.

**1. Check that:**

- (1) An RS-485 communications card is contained in the package.
- (2) The RS-485 communications card is not damaged during transportation--no defective devices, dents or warps.
- (3) The model name "OPC-E2-RS" is printed on the RS-485 communications card. (See Fig.1.)

If you suspect the product is not working properly or if you have any questions about your product, contact the shop where you bought the product or your local Fuji branch office.

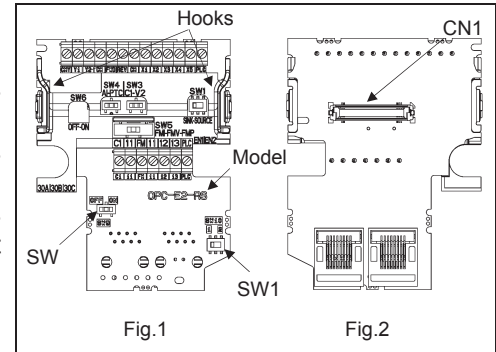

**2. Installation Method**

**⚠ WARNING**

Before carrying out installation and wiring, wait ten minutes or longer after turning OFF the power. Finally, ensure that the LED monitor and charge lamp have turned OFF, and use a tester to confirm that the DC relay circuit voltage across main circuit terminals P(+) to N(-) has dropped to a safe level (+25 VDC or below).

**Failure to observe this could lead to electric shock.**

In order to prevent damage resulting from static electricity, when handling the card, either take antistatic prevention measures, or hold the hooks to prevent touching the PCB directly.

- (1) If multiple inverters are connected, always turn ON switch SW9 (Fig. 1) on the RS-485 communication card installed on the last inverter.
- (2) Remove the inverter unit cover to expose the interface board.  
 Refer to the unit instruction manual for details on how to remove the cover.
- (3) If the inverter unit is equipped with an interface board, (1) remove the short bar, (2) hold down the hooks, and then remove the interface board (Fig. 3) (The removed interface board is not used.)
- (4) Insert connector CN1 (Fig. 2) on the RS-485 communication card into connector CN1 (Fig. 3) on the inverter until it clicks into place, and then fit a short bar to the PLC, EN1, and EN2 terminals.  
 Refer to the unit instruction manual for details on the screw tightening torque to be applied when fitting the short bars.
- (5) Replace the inverter unit cover.  
 Refer to the unit instruction manual for details on how to replace the cover.

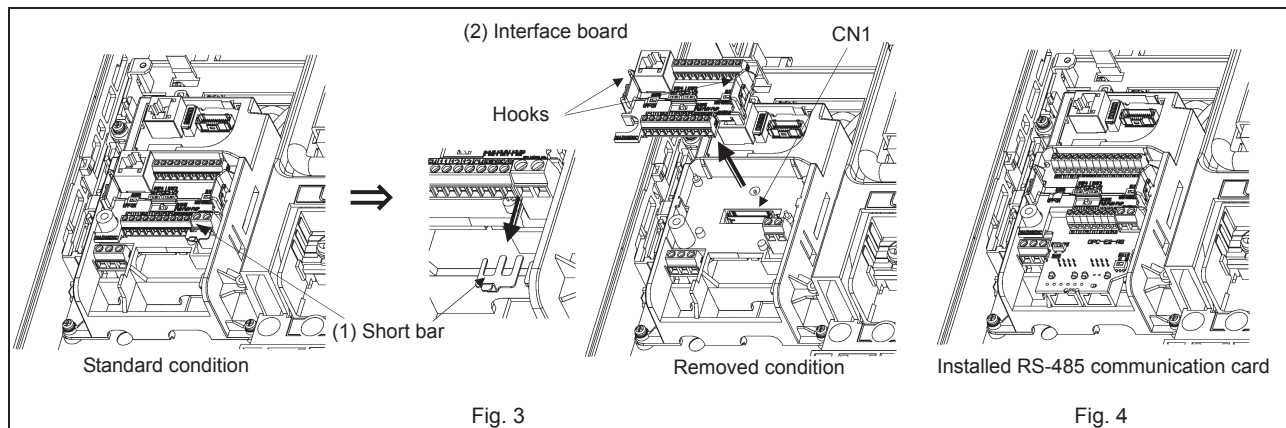

**⚠ WARNING**

The coating on control signal wires generally does not have reinforced insulation, and so for some reason there may be times when the insulating coating is damaged if control signal wires come into contact with live parts on the main circuit. There is consequently a risk that high main circuit voltage will be applied to control signal wires, and therefore care must be taken to ensure that there is no contact between live parts and control signal wires.

**Failure to observe this could lead to an accident or electric shock.**

**⚠ CAUTION**

Noise is produced by the inverter, motors, and wires. Take measures to prevent malfunctions occurring at surrounding sensors and devices.

**Failure to observe this could lead to an accident.**

Refer to the following connection terminal allocation drawing and terminal specifications when wiring to the RS-485 communication card.

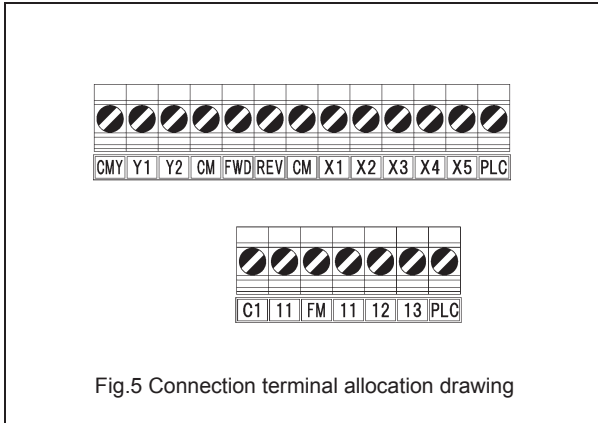

Table 1 Terminal specifications

Terminal size	M2
Tightening torque (N·m)	0.19 ±10%
Recommended wire size *	AWG16 - 24
Stripped wire length (mm)	5

\* An insulated wire with allowable temperature of 105° (UL compliant product) is recommended.

**FRN0072E2-4 example**  
Cut out part of the wiring guide and pass through the wires from the RS-485 communication card.

**FRN0203E2-4 example**

**FRN0590E2-4 example**  
Secure the wires from the RS-485 communication card to the side plate amp base with a cable tie.

#### 4. Terminal Block Specifications

【Terminal arrangement】			【Names and functions】	
Terminal Number	Terminal symbol		Terminal name	Function
	SW10=1 (default)	SW10=2 *1		
1,6,7,8	N.C.		DX+	RS-485 communication data (+) terminal
2	SD		DX-	RS-485 communication data (-) terminal
3	N.C.	DX-	SD	Shield terminal
4	DX-	DX+	N.C.	No connection
5	DX+	N.C.		

\*1: The terminal arrangement which is compatible with FVR-E11.

If a setup of SW10 is mistake, there is fear of breakage.

#### 【Terminal assignment】

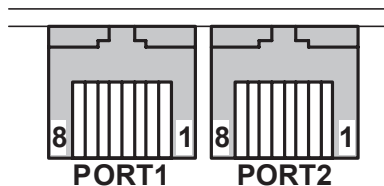

#### 【Internal circuit】

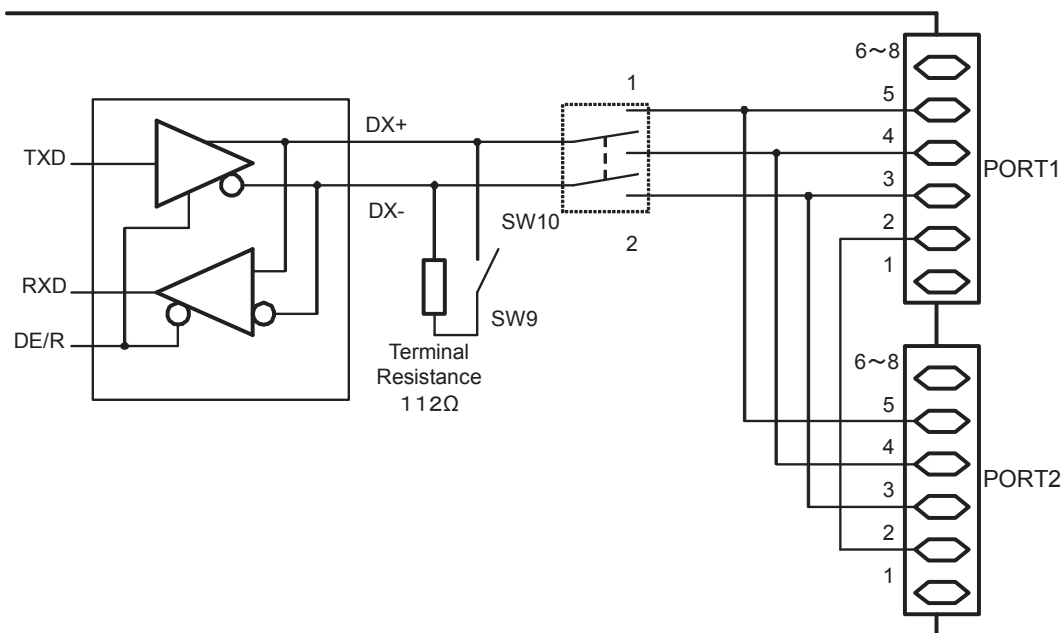

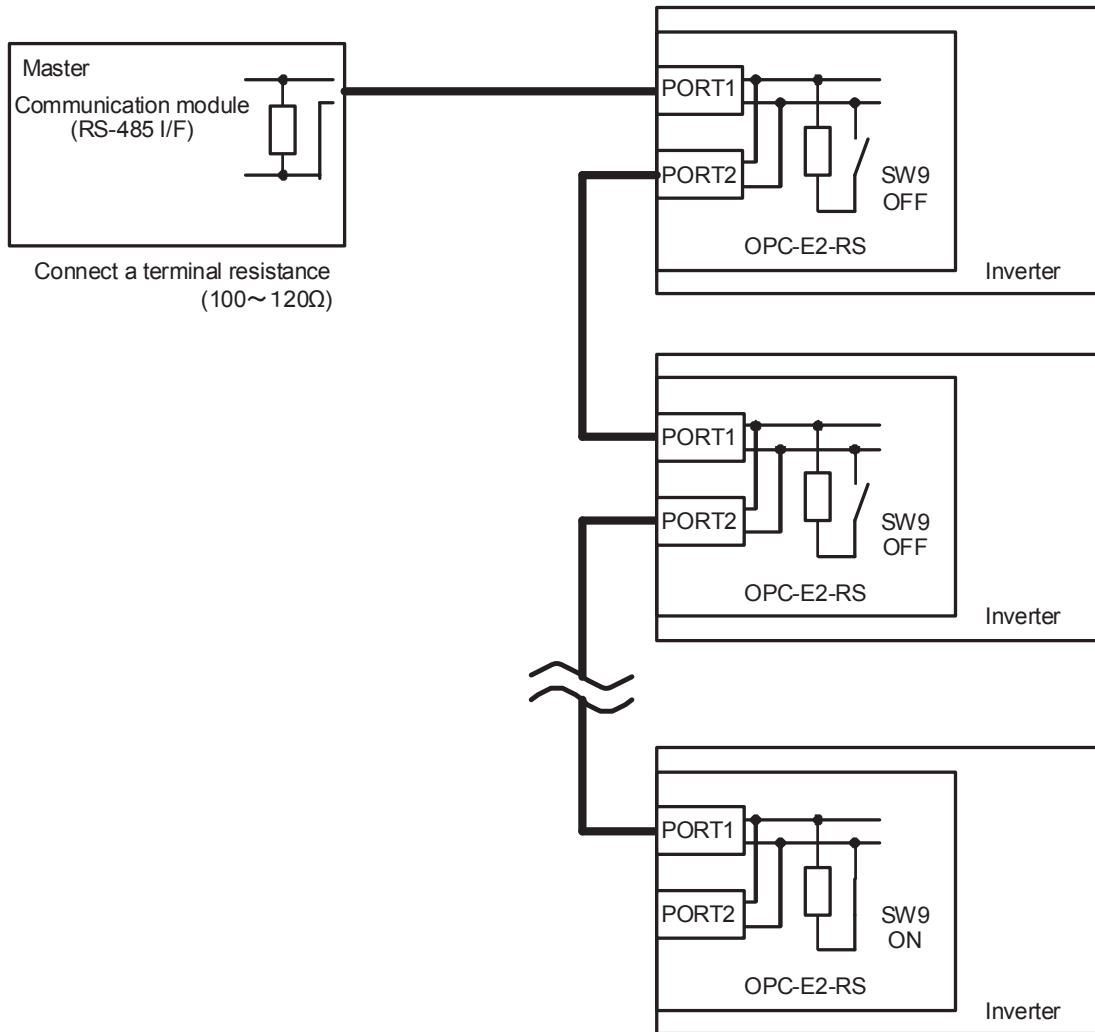

- The insulation type converter is recommended to communicate with a PC having USB or RS-232C as mater as shown in the table below.

Interface	Recommended converter	Manufacture
USB	USB-485I Series	System Sacom Sales Corp., Japan
RS-232C	KS-485PTI	System Sacom Sales Corp., Japan

- Use the straight connection cable conforming with ANSI/TIA/EIA-568A category 5
- Turn on SW9 for the terminal resistance when the inverter is installed at the end of communication line. SW9 is OFF as the factory default.
- The cable length shall be 500m or less.
- Do not connect the inverter to PC LAN ports, Ethernet hubs, or telephone lines. The inverter and the connected instrument may be damage.

**Fuji Electric Co., Ltd.**

Gate City Ohsaki, East Tower, 11-2, Osaki 1-chome, Shinagawa-ku, Tokyo, 141-0032, Japan

Phone: +81 3 5435 7058 Fax: +81 3 5435 7420

URL <http://www.fujielectric.com/>