

CROSS STACK LASER GAS ANALYZER (Dual beam version)

DATA SHEET

ZSS-D

Cross stack laser gas analyzer (ZSS) provides continuous measurement of CO and O₂ contained in flue gas in various plants. Because ZSS is installed directly on the stack or the pipe through which the target gas passes, sample gas conditioning is not required. Being highly tolerant to dust, ZSS can be installed on the upstream of a bug filter where the gas sampling is usually difficult. ZSS is the first laser gas analyzer in Japan that is designed for environmental monitoring and process monitoring.

FEATURES

1. Double-beam laser for two component analysis of CO and O₂
2. Low maintenance
3. Low operating-cost: with no gas-sampling device and few parts to be replaced
4. Superior long-term stability
5. Fast response speed within 4 seconds—suited to combustible gas monitoring and control in converter furnaces
6. Tolerant to high temperature and high dust
7. Environment friendly: 80 VA, low power consumption
8. Analog output for transmittance is available
9. Compliant with RoHS directive



SPECIFICATIONS

Table 1. Measurable component, Measurable range

No. of components	Component		Minimum range *1	Maximum range *1	Gas temperature	Purge gas	4th digit
2-laser 2-component analyzer	CO+O ₂ (Instrument air purge)	CO	200 ppm	2 vol%	400–1200°C	Instrument air	V
		O ₂	25 vol%	100 vol%			
	CO+O ₂ (High temperature)	CO	200 ppm	2 vol%	≤ 1200°C	N ₂	U
		O ₂	5 vol%	50 vol%			
	CO+O ₂	CO	2 vol%	50 vol%	≤ 300°C		S
		O ₂	10 vol%	100 vol%			

Note 1) The minimum and maximum measuring range in the above table are for measuring path length (stack length) of 1m. See below on the ranges for other path lengths.

Calculation method of measuring range for optical path length other than 1m

Measuring range = [Min. or Max. range ÷ path length]

<p>Example 1) CO analyzer, path length 5m Max. range: 2 vol% ÷ 5m = 4,000ppm Min. range: 200ppm ÷ 5m = 40ppm Therefore, measuring range is between 0 to 40 …4,000ppm</p>	<p>Example 2) CO analyzer, path length 0.5m Max. range: 2 vol% ÷ 0.5m = 4 vol% Min. range: 200ppm ÷ 0.5m = 400ppm Therefore, measuring range is between 0 to 400ppm …4 vol%</p>
--	---

Measurement principle:

Non-dispersive infrared (NDIR)

Measuring method:

Cross-stack system (path system)

Application:

Waste incineration plant, industrial waste disposal facility, power plant iron and steel plant, paper plant, pulp mill, chemical plant and bioplant, etc.

Light source:

Near-infrared laser

Laser class:

Class 1 (High temperature version and instrument air purge version fall under CLASS 3B)

Dimensions:

Refer to outline diagram

Weight (excluding cables):

Receiver unit and transmitter unit: Approx. 10 kg

Control unit: Approx. 8 kg

Structure:

Outdoor use, dustproof and rainproof (IP65)

Finish color:

Receiver/Transmitter box: gray

Control unit cover: blue

Control unit case: silver

Material:

Receiver unit and transmitter unit: aluminum, stainless steel 316

Control unit: Aluminum

Materials of gas-contacting parts:

Stainless steel 316, BK7, FKM, PTFE, glass-cloth, silicone

Air purge connection diameter:

RC1/4 (tube connection: 10/8)

Power supply:

Rated voltage: 100–240 V AC (operating voltage: 90–264 V AC)

Rated frequency: 50/60 Hz

Power consumption:

80 VA or less

Display:

Backlit LCD

Display contents:

Component, concentration (instantaneous value, average value, O₂ correction instantaneous value and O₂ correction average value), alarm (fault status)

Communication:

RS-485 (Modbus)

Cable length:

Receiver unit to transmitter unit: Standard 2 m (Maximum 25 m)

Receiver unit to control unit: Standard 5 m (Maximum 100 m)

Analog output:

No insulation, 2 or 4 points

Signal	Allowable load
4–20 mA DC	≤ 550 Ω
1–5 V DC	≥ 500 kΩ

(Transmits the measured value and the O₂-corrected value, and/or the transmittance (%T). User can switch between average values and instantaneous values.)

Analog input:

4–20 mA DC, 2 points

Measured gas pressure, measured gas temperature, measured gas velocity, O₂ concentration, water concentration, or air purge pressure

* Analog inputs are used for the concentration compensation, the O₂ correction, and the alarm output.

Digital output:

6 points, SPST-NO (standard) or SPST-NC

Relay contact, contact capacity 24 V DC, 1 A

Low light transmission, device failure, during hold / during calibration, H/L limit, environmental error, power interruption

Digital input (option):

3 points

Voltage input, received by photocoupler (operating voltage 12–24 V DC, current 5–20 mA)

Average value reset, switchover between instantaneous value and moving average value, remote hold

PERFORMANCE

(at 25°C and 0.1 MPa)

Repeatability:

±2.0% FS (depends on component, range, optical path length)

Linearity:

±3.0% FS (depends on component, range, optical path length)

Zero point drift:

±4.0% FS per 6 months (depends on component, range, optical path length)

Span drift:

±4.0% FS per 6 months (depends on component, range, optical path length)

Cross interference:

±2.0% FS

Detection limit:

1% of minimum range

Response time (for 90% FS response):

≤ 4 s

Warm-up time:

≤ 90 min

FUNCTIONS**DIGITAL OUTPUT****Low light transmission:**

Contact is opened or closed when the intensity of the light reached the receiver is deficient.

Device failure:

Contact is opened or closed when any of the followings occurs: Laser temperature error, light intensity high, communication error

During hold/during calibration:

Contact is opened or closed during the analog output is held (to the last value or the user-defined value) and during calibration.

H/L limit:

Contact is opened or closed when the measured value has gone beyond the high limit or below the low limit.

Environmental error:

Contact is opened or closed when the gas temperature is outside the range, air purge pressure is too low, analog input signal is abnormal, and/or box temperature is abnormal.

Power interruption:

Contact is opened or closed during the power supply to the analyzer is interrupted.

DIGITAL INPUT (OPTION)

Average value reset signal:

Output of converted average value is started from the initial state by applying rectangular-wave voltage (with a minimum pulse width of two seconds) to the input terminal of average value resetting. Output is reset by inputting and restarted by opening.

Switchover between instantaneous value and moving average value:

Switching to and from the instantaneous value and the average value of the analog output is performed by applying rectangular-wave voltage (with a minimum pulse width of two seconds) to the input terminal for switching between the instantaneous value and the moving average values.

Remote hold:

The analog output is held by applying voltage to the remote hold input terminal. The hold is cancelled by opening the relay contact.

O₂ CORRECTION:

Conversion of measured gas concentrations into values at standard O₂ concentration

Correction formula:

$$C = \frac{21 - O_n}{21 - O_s} \times C_s$$

C: Converted concentration

C_s: Measured concentration of sample gas

O_s: Measured O₂ concentration (Upper limit settable 1 to 20% O₂)

O_n: Standard O₂ concentration (value changeable by setting; 0 to 19% O₂)

The result of calculation is indicated and output in an analog output signal.

DRY/WET VALUE OUTPUT

A user can switch the indication and the output between wet values (concentrations which include moisture) and dry values (concentration from which the moisture content is eliminated). The moisture concentration can be set by key or by the analog input.

SAMPLE GAS REQUIREMENTS

Temperature:

Refer to Page 1.

* For measurement of high temperature gas of 500°C or above, install a pressure sensor on the purge line to monitor the purging status. If the purge is suspended under the high temperature gas environment, the product may be seriously damaged.

Pressure:

±10 kPa (Consult us if the gas pressure exceeds this limit.)

Moisture:

≤ 50 vol% (no condensation)

Velocity:

Flow velocity (m/s) = purge gas flow rate of each side (L/min) / 10

Dust (when the optical path length is 1 m):

Standard version: ≤ 5 g/m³ (N)

Dust resistant, high speed AGC version:

O₂ measurement: ≤ 10 g/m³ (N)

CO measurement: ≤ 15 g/m³ (N)

Consult us if your application has high dust. Dust resistance varies with the target gases, specification, optical path length, particle size of dust, and other conditions.

INSTALLATION ENVIRONMENT

Ambient temperature:

-20°C to +55°C (receiver unit and transmitter unit)

-5°C to +45°C (control unit)

Ambient humidity:

≤ 90% RH

Storage conditions:

Temperature: -20°C to +60°C

Humidity: ≤ 95% RH

Optical path length (stack inner diameter):

0.5 m to 5 m

* Consult us if the distance between the transmitter unit and the receiver unit is beyond 5 m.

Standard flange:

JIS 10K 50A flange (JIS B 2212)

Purge gas:

Instrument air purge version: Instrument air

Other than above: N₂

Purge gas pressure:

≥ 0.3 MPa (depending on the flow velocity of target gas)

Purge gas flow rate:

≥ 20 L/min (depending on measured gas velocity)

Flow rate of each purge line (50A pipe) (L/min) = measured gas flow velocity (m/s) × 10

Vibration:

0.5 G or less (0.2 G or less when the frequency range is 20 to 40 Hz) (when optical path length is 1 m)

Mounting angle:

Horizontally ±5 degrees or less (No dew condensation should accumulate on the window.) Refer to Page 11.

CALIBRATION

Cycle:

Every 6 months (the cycle may vary depending on the installation environment)

Method:

Remove the transmitter and the receiver from the stack, attach them to the calibration cells, and flow the standard gas with a flow rate of 1.5 to 2.0 L/min. (calibration cells and standard gas are to be prepared separately)

Zero gas:

Dry N₂

Span gas:

80% to 100% concentration of each range × optical path length, balance N₂

(when the calibration cell is 1 m)

EC DIRECTIVE COMPLIANCE

LVD (2014/35/EU)

EN 61010-1

EN 62311

EN 60825-1

EMC (2014/30/EU)

EN 61326-1 (Table 2)

EN 61000-3-2 (Class A)

EN 61000-3-3

EN 61326-2-3

RoHS (2011/65/EU+(EU)2015/863)

EN IEC63000

CODE SYMBOLS

When ordering, be sure to submit the order sheet on the last page of this Data Sheet.

ZSS 4 5 6 7 8 - 9 10 11 12 13 - 14 15 16 17 18 19 20 - 21 22

ZSS 8 - A - 0 - N Note 5)

Digit	Specification	Note	Code		
4	Measurable components		ppm CO + O ₂ (Air purge)	V	
			ppm CO + O ₂ (High temperature)	U	
			vol% CO + O ₂	S	
5	Unit		ppm (1st comp), vol% (2nd comp)	7	
			vol% (1st comp), vol% (2nd comp)	9	
6	Measuring range (CO)	Note 1	0 to 2	K	
			0 to 2.5	Q	
			0 to 4	S	
			0 to 5	L	

			0 to 10	V	
			0 to 15	0	
			0 to 20	1	
			0 to 25	T	
			0 to 50	A	

			0 to 100	B	
			0 to 200	C	
			0 to 250	D	
0 to 400	J				
0 to 500	E				

0 to 1000	F				
0 to 2000	G				
0 to 5000	H				
0 to 6000	M				
Others	X				
7	Measuring range (O ₂)	Note 1	0 to 5	L	
			0 to 10	V	

			0 to 15	0	
			0 to 20	1	
			0 to 25	T	
			0 to 50	A	
0 to 100	B				
Others	X				
9	Flange rating		10K 50A (JIS B 2212)	A	
			10K 100A	B	
			DN50/PN10	C	
			ANSI #150 2B	D	
10	Number of analog output points		2 points	0	
			4 points	1	
11	Number of analog input points		2 points	A	
12	Analog output		4 to 20mA DC	1	
			1 to 5V DC	5	
13	DI/DO		6 output points, No input	0	
			6 output points, 3 input points	1	

Digit	Specification	Note	Code	
14	Cable length between receiver and control unit	Note 2	5m	A
			10m	B
			20m	C
			30m	D
			40m	E
			50m	F
15	Cable length between receiver and transmitter	Note 3	2m	A
			5m	B
			10m	C
			15m	D
			20m	E
			25m	F
16	Display and operation manual		Japanese	J
			English	E
			Chinese	C
17	-	-	0	
18	Measuring optical path length (unit: 1m)	Note 4	0m	0
			1m	1
			2m	2
			3m	3
			4m	4
5m	5			
19	Measuring optical path length (unit: 0.1m)	Note 4	0.0m	0
			0.1m	1
			0.2m	2
			0.3m	3
			0.4m	4
			0.5m	5
			0.6m	6
			0.7m	7
			0.8m	8
0.9m	9			
20	Measuring optical path length	Note 4	0.00m	0
			0.05m	5
21	-	-	N	
22	High-dust version (High-speed AGC)		No	N
			Yes	H

Notes:

1. Select the appropriate range within the limit calculated based on the optical path length of your application.
2. Cable length between receiver and control unit: when you select the code "X", available length is 10 m or longer.
3. Cable length between receiver and transmitter: when you select the code "X", available length is 5 m or longer.
4. When the optical path length is 5 m, select "5" in the 18th, and "0" in the 19th and the 20th codes.
5. From 23th code, this specify particular specification according to delivery specification.

COMBINATIONS OF MEASURABLE COMPONENTS AND RANGES

Component		Measuring range
CO+O ₂ (Instrument air purge)	1st comp.: CO	0 – 200, 250, 400, 1000, 2000, 5000, 6000 ppm, 2vol%
	2nd comp.: O ₂	0 – 25, 50, 100 vol%
CO+O ₂ (High temp.)	1st comp.: CO	0 – 200, 250, 400, 1000, 2000, 5000, 6000 ppm, 2vol%
	2nd comp.: O ₂	0 – 5, 10, 15, 20, 25, 50 vol%
CO+O ₂ (vol%CO+ O ₂)	1st comp.: CO	0 – 2, 4, 5, 10, 15, 20, 25, 50 vol%
	2nd comp.: O ₂	0 – 10, 15, 20, 25, 50, 100 vol%

BASIC PRINCIPLE

ZSS uses the near-infrared semiconductor laser as the light source, and photo-diode as photodetector. Each gas component has its own wavelength range where it absorbs the light, and a wavelength range consists of a set of many absorption lines, as shown in the figures below. As ZSS can aim at only one absorption-line among them, the measurement principally receives no interference from other gases. ZSS also focus on the amplitude of modulated signal, instead of the amount of change in light intensity, to detect gas concentration.

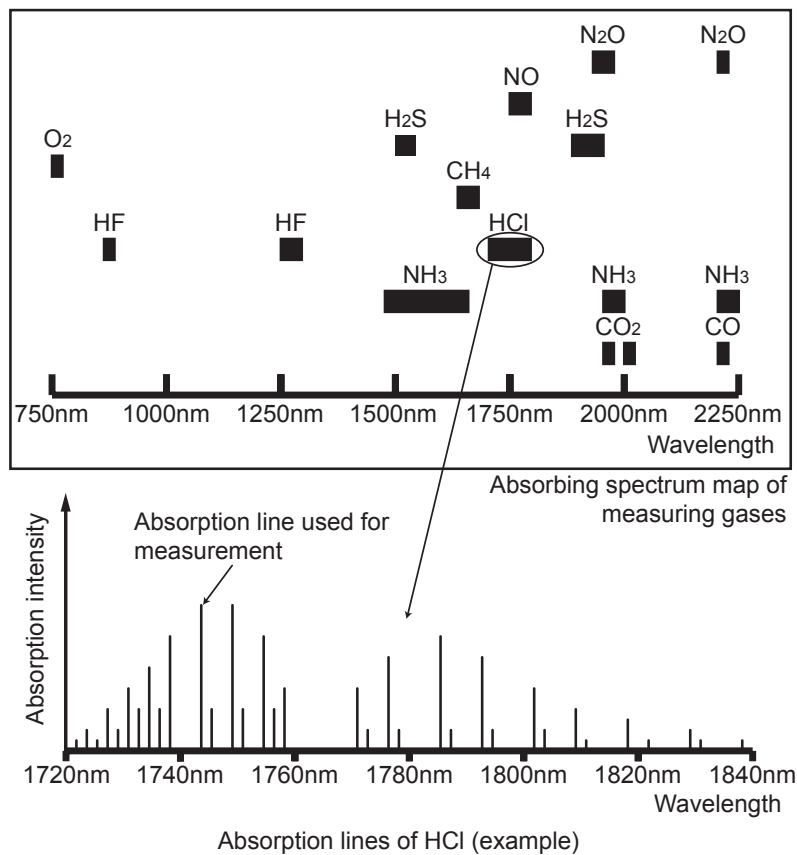

CALIBRATION/INSTALLATION FIXTURES LIST (OPTION)

	Parts name	Quantity	Type
(1)	Cable between receiver unit and control unit (for calibration)	1	ZZP*ZSSTQ404686C2
(2)	Cable between receiver unit and transmitter unit (for calibration)	1	ZZP*ZSSTQ404685C3
(3)	Calibration gas cell (*3) (CO+O ₂)	1	ZZP*ZSSTQ404736C1
(4)	Optical axis adjusting tool (laser pointer, target)	1	ZZP*ZSSTQ404743C1
(5)	Check cell	1	ZZP*ZSSTQ404742C1
(6)	Filter regulator	1	ZZP*ZSSTQ505311P1
(7)	Mist separator	1	ZZP*ZSSTQ505310P1
(8)	R1/4 cap nut (plug) for mist separator	1	ZZP*ZSSR850N000075
(9)	Flow meter (20 to 100L/min) (*4)	1	ZZP*ZSSTQ505309P1
	Flow meter (4 to 50L/min) (*4)	1	ZZP*ZSSTQ505309P2
	Flow meter (30 to 300L/min) (*4)	1	ZZP*ZSSTQ505308P1
(10)	Air-set box (20 to 100L/min)	1	ZZP*ZSSTQ505307C1
	Air-set box (4 to 50L/min)	1	ZZP*ZSSTQ505307C2
	Air-set box (30 to 300L/min)	1	ZZP*ZSSTQ505307C3
(11)	Air purge mechanism (20 to 100L/min)	1	ZZP*ZSSTQ505299C1
	Air purge mechanism (4 to 50L/min)	1	ZZP*ZSSTQ505299C2
	Air purge mechanism (30 to 300L/min)	1	ZZP*ZSSTQ505299C3
(12)	BNC cable for optical axis adjustment	1	ZZP*ZSSTQ505298C1

- * 3: Standard length 1m (250mm or 500mm when the measuring range is low concentration)
- * 4: Usually, 2 units are required to adjust each air purge for receiver unit and transmitter unit.

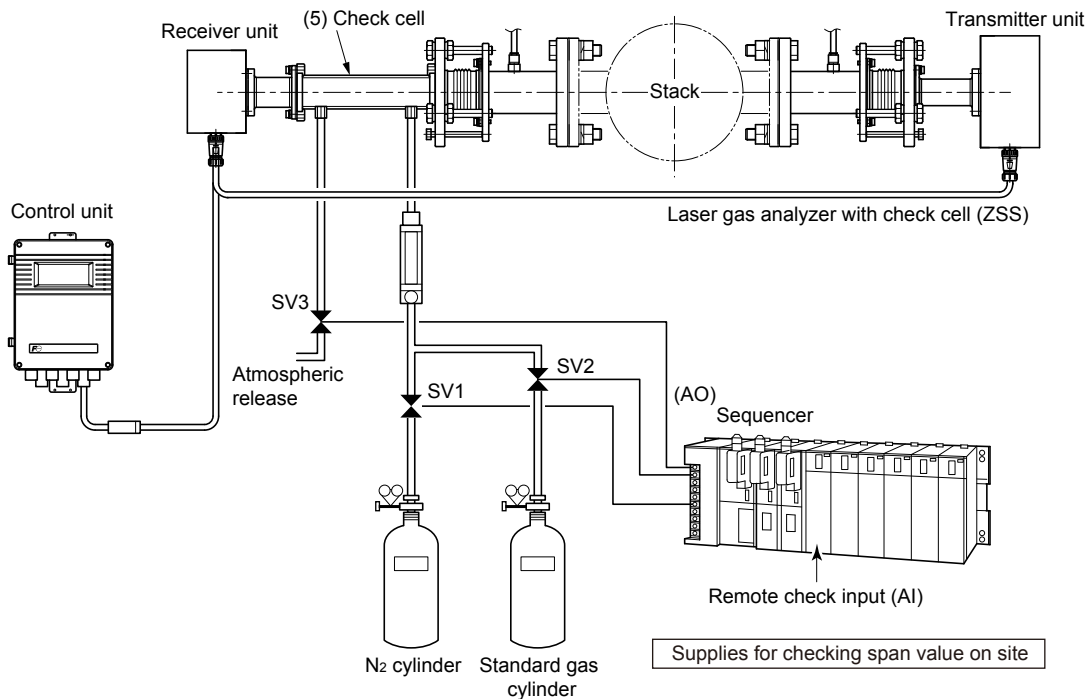
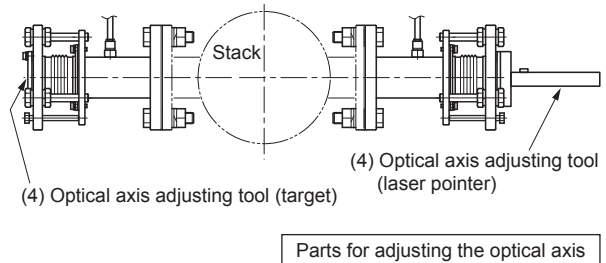
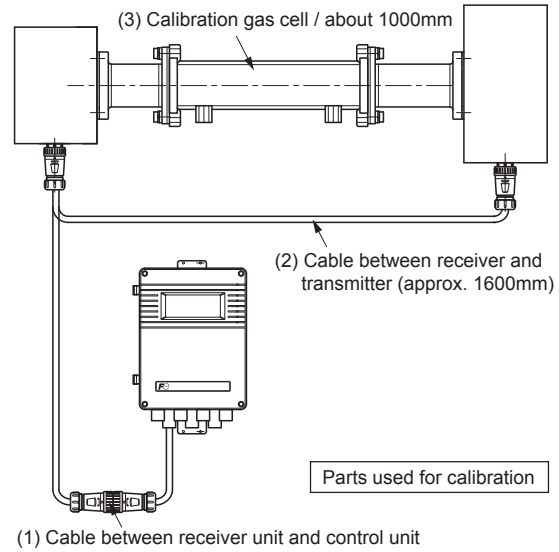

(10) Air set box

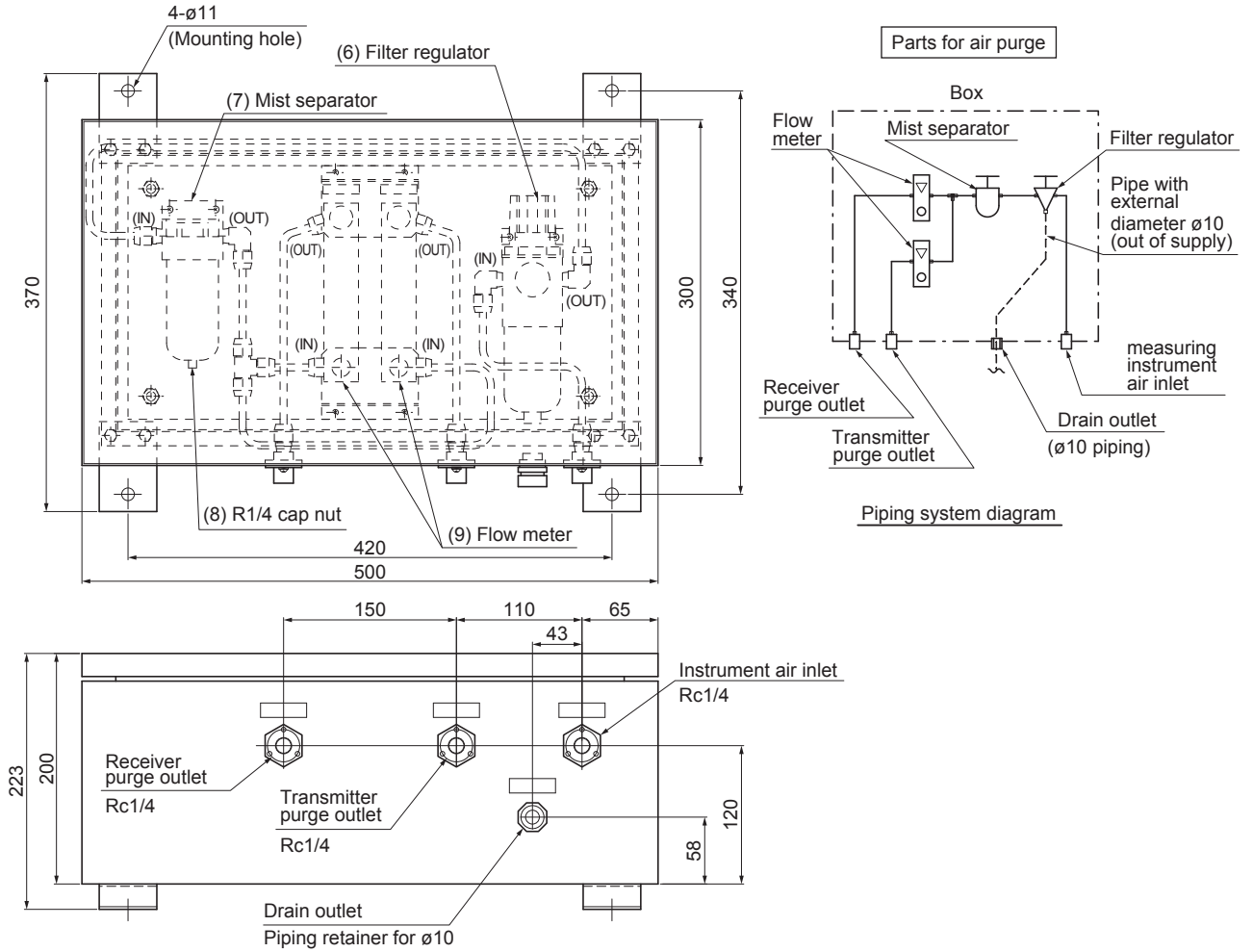

(11) Air purge mechanical part

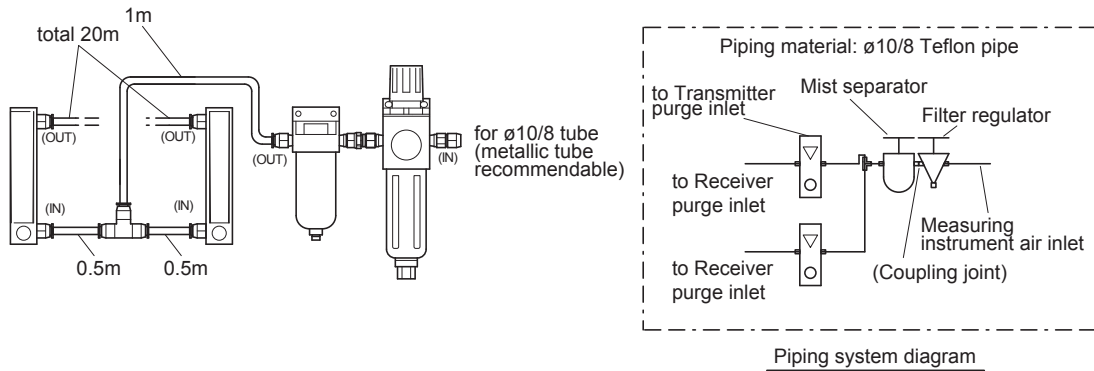

(12) BNC cable for optical axis adjustment

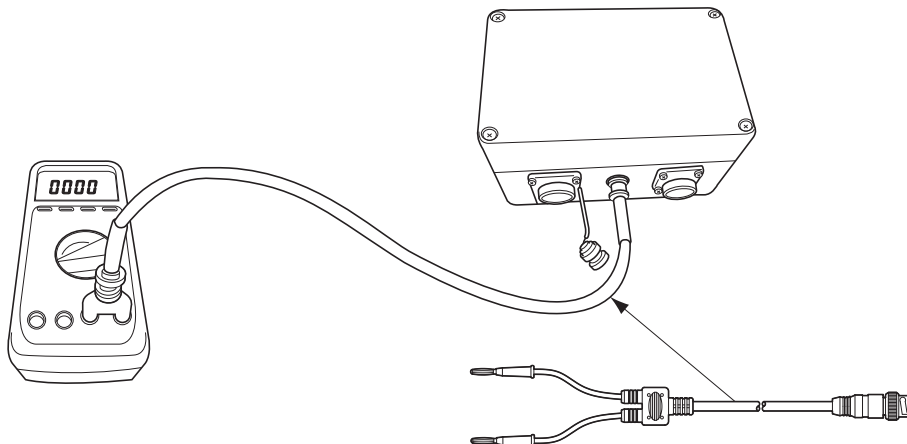

OUTLINE DIAGRAM (Unit : mm)

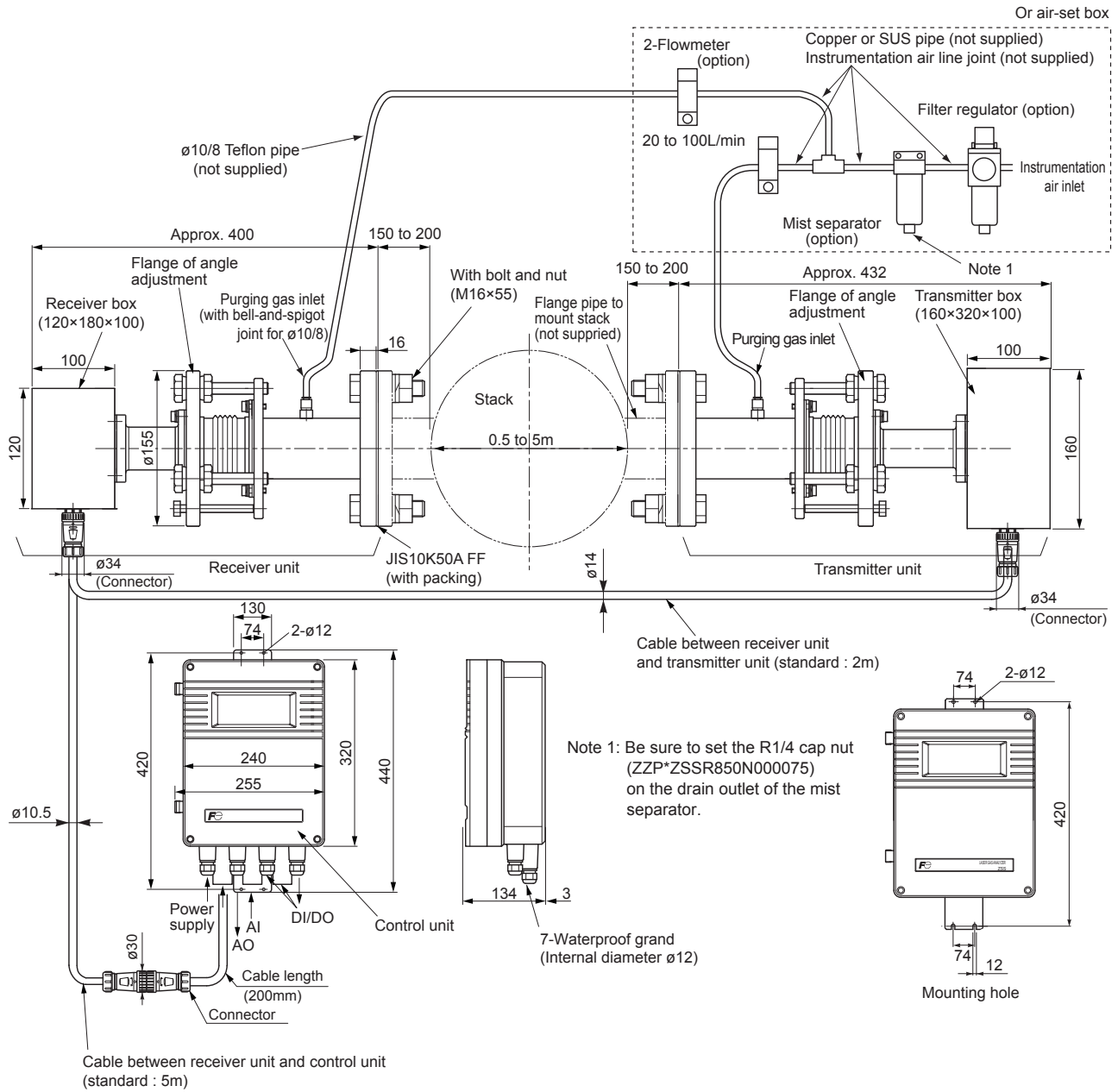

Notes:

- For O₂ analyzers other than the instrument air purge version, use N₂. For all the other cases, use instrument air. If you use air that contains oil and/or mist, the purge gas flow decreases due to the contaminant, which adversely affects the measurement. In such a case, frequent maintenance is required, and in some cases you may have to install a filter additionally.
- Once you install the analyzer, you have to purge the equipment with instrument air or N₂ regardless if the analyzer and the furnace are in operation or not. If you operate the furnace without purging, it may cause the fatal damage to the optical part.

EXTERNAL CONNECTION DIAGRAM

Power terminal



- M4 screw
- 1 100-240 V AC, 50/60 Hz (L)
- 2 100-240 V AC, 50/60 Hz (N)

PE terminal

- PE Protective earth
- M4 screw

AI/AO/DI/DO terminal

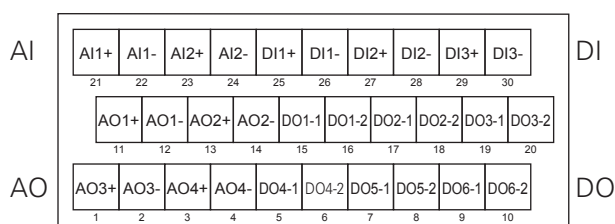

- M3 screw
- Cross-sectional area of wire: AWG26-16

AO terminals

- 11 AO1+ } Analog output 1 (AO1)
- 12 AO1- }
- 13 AO2+ } Analog output 2 (AO2)
- 14 AO2- }
- 1 AO3+ } Analog output 3 (AO3) (AO extension board is required)
- 2 AO3- }
- 3 AO4+ } Analog output 4 (AO4) (AO extension board is required)
- 4 AO4- }

AI terminals

- 21 AI1+ } Analog input 1 (AI1)
- 22 AI1- }
- 23 AI2+ } Analog input 2 (AI2)
- 24 AI2- }

DI terminals

- 25 DI1+ } Average resetting signal (option)
- 26 DI1- }
- 27 DI2+ } Instantaneous/average switching signal (option)
- 28 DI2- }
- 29 DI3+ } AO holding signal (option)
- 30 DI3- }

DO terminals

- 15 DO1-1 } Light intensity low
- 16 DO1-2 }
- 17 DO2-1 } Device failure
- 18 DO2-2 }
- 19 DO3-1 } During hold/during calibration
- 20 DO3-2 }
- 5 DO4-1 } Overrange/underrange
- 6 DO4-2 }
- 7 DO5-1 } Environmental error
- 8 DO5-2 }
- 9 DO6-1 } Power interruption
- 10 DO6-2 }

Notes:

- Device failure includes laser temperature error, communication error, and overrange.
- Environmental error includes gas temperature error, purge air pressure underrange, analog input signal error, and box temperature error.
- Consult us if you want to use any alarms (relay outputs) dependent on the installation environment.
- It takes at least 5 minutes until all the alarms except for the communication error start to work. Alarm for "light intensity low" is triggered if the alarm status continues at least 1 minute, which means 6 minutes after the power is turned on.
- AI terminal, AO terminal, and DI/DO terminal are all on the same board.

SCOPE OF DELIVERY

- Receiver box
- Transmitter box
- Control unit
- Angle adjustment mechanical section (required 2 units, one for receiver and the other for transmitter)
- Cable between receiver unit and transmitter unit (specified length)
- Cable between receiver unit and control unit (specified length)
- Standard accessory set, instruction manual

OPTIONAL ITEMS

- Spare parts for one year (ZBN1SS12)
- Calibration gas cell (*1) (*2)
- Cable between receiver unit and transmitter unit (For calibration) (*1)
- Cable between receiver unit and control unit (For calibration) (*1)
- Standard gas (ZBM), pressure regulator (ZBD)
- Recorder (when necessary, Fuji's product type PHL/PHF, etc.)
- Others

*1: One set of the cables and calibration gas cell are necessary for installation and annual maintenance.

*2: The length of the calibration gas cell may vary with measurement ranges.

STANDARD ACCESSORIES

Name	Quantity	Specification
Bolt	8 or 16 *1	M16 × 55 (70) *2, stainless steel
Nut	8 or 16 *1	M16, stainless steel
Spring washer	8 or 16 *1	M16, stainless steel
Flat washer	8 or 16 *1	M16, stainless steel
Companion flange packing or flange packing specified for use in high temperature	2	According to flange specifications
Bolt for angle adjustment	6	Hex socket bolt M8 × 70
Power supply fuse	2	
Connecting bolt between receiving unit and transmitter unit	12	Hex socket bolt M5 × 12

Notes:

1. When the 9th code is "B", 16 pieces are provided. For other cases, 8 pieces are provided.
2. When the 9th code is "A", the bolt length is 55 mm. When the 9th code is "B", "C", or "D", the bolt length is 70 mm. Inch-sized bolts are not supplied.

SPARE PARTS FOR ONE YEAR (ZBN1SS12)

Name	Quantity	Remarks
Silicone packing A	2 pieces	For bellows (ZZP*ZSSTQ505205P1)
O-ring	2 pieces	(ZZP*ZSSR8552850)

MOUNTING DIMENSIONS (Unit: mm)

Keep purging the analyzer once you install it on a stack.
Otherwise, the contamination of optical surface may result in the analyzer failure.

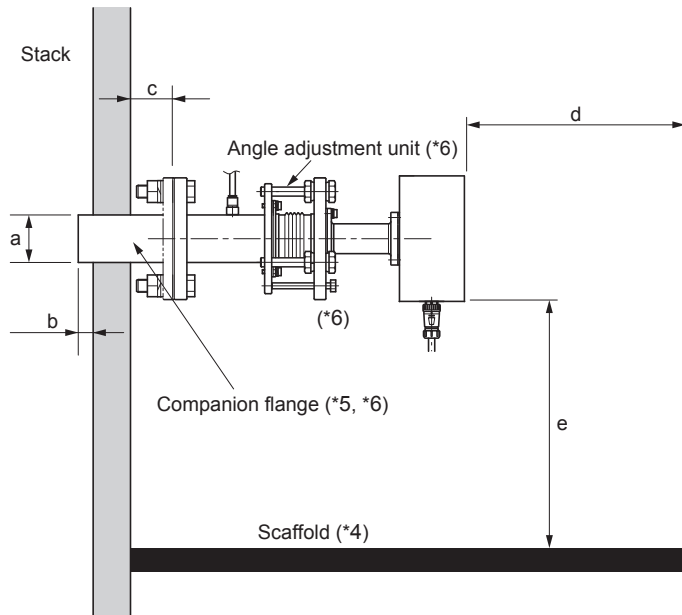

- a: inside diameter ≥ 50 mm
- b: 20 to 70 mm (*1)
- c: \geq approx. 200 mm (*2)
- d: ≥ 400 mm (*3)
- e: 500 to 1500 mm(*3)

- *1: When the flue gas contains a large amount of dust, ensure the minimum length of 50 mm.
- *2: When the flue gas temperature is high (400°C or more), ensure the minimum distance of 400 mm.
Note that in that case you have to be even more careful in adjusting the angle of the companion flange because the angle range within which the companion flange can be adjusted is narrow.
- *3: Make sure to install the analyzer in the place where it is easy to operate, and where there is enough clearance.
- *4: Scaffold is required for both the receiver unit side and the transmitter unit side.
- *5: Use a flanged valve where there is a risk of gas blowout or where the operator may be exposed to a dangerous situation.
- *6: Tightening torque for the companion flange shall be 118 ± 14 N·m. When tightening the bolts of the flange or the angle adjustment unit, apply grease to the bolts. (Recommended grease is the one contains molybdenum.)

ROUGH GUIDE TO MOUNT THE COMPANION FLANGE

When θ is larger than 5° , attach the companion flange with the γ angle $\leq 5^\circ$ inside the circumference of radius A.

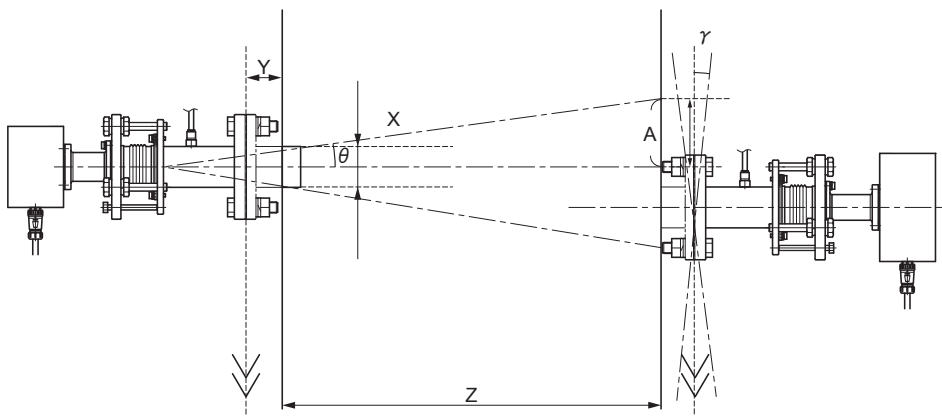

- X: Flange inner diameter of receiver unit and transmitter unit
- Y: Distance between the outer wall of the duct and each flange of the transmitter unit and the receiver unit
- Z: Inner diameter of stack

$$\theta = \tan^{-1} \frac{X}{2(Y + 125)}$$

$$A \approx 0.087 \times (Z + Y + 125)$$

$$\tan 5^\circ \approx 0.087$$

Please specify the following items when you contact us for inquiry.

1. Code symbol ZSS _____

2. Parameter of measured gas

Item	Min. value	Typical value	Max. value
Measured gas concentration (CO)			
Measured gas concentration (O ₂)			
Temperature (°C)			
Pressure (kPa)			
Flow (m/s)			
Moisture (vol%)			
Dust (mg/m ³ (N))			
Other gas component (vol%/ppm)			
Other gas component (vol%/ppm)			
Other gas component (vol%/ppm)			

3. Stack inner diameter (optical path length)

A m

4. Distance from stack (outside wall) to flange

B m

5. Distance from stack (outside wall) to flange

C m

6. Cable between receiver unit and control unit

D m

7. Cable between receiver unit and transmitter unit

E m

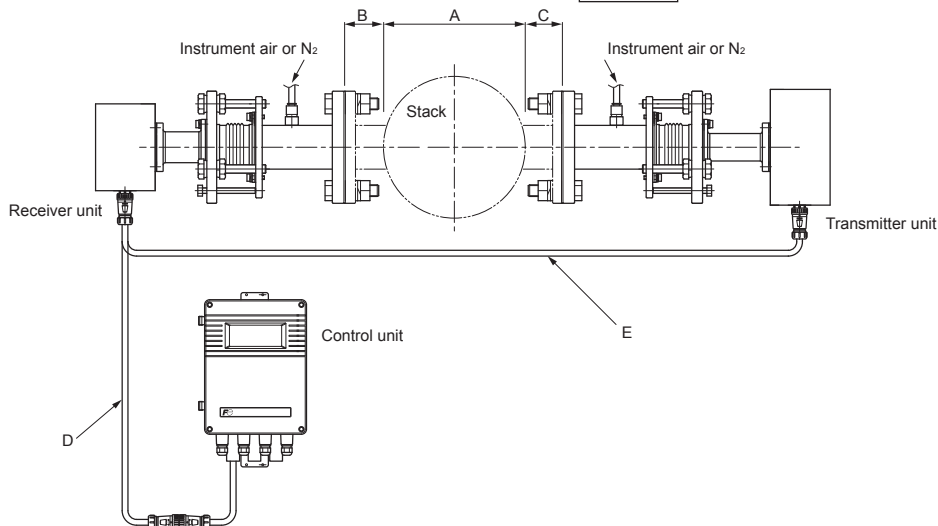

8. Spares for 1-year measurement

no need/necessary

9. Separate order items

no need/necessary

10. Output of O₂ correction value

no need/necessary

11. Reference O₂ concentration value (vol%) (When "necessary" is selected in 10)

_____ vol%

12. Presence of vibration

no need/necessary (_____G)

⚠ Safety information

- Be sure to read thoroughly the instruction manual before use.
- When this product is installed in a flue and as long as no one enters in the flue, this product can be used as Class 1 laser product. However, be sure to follow the instructions below for safety because the product emits laser beam when energized.
 - Do not remove the transmitter unit, the receiver unit, or any part of them from the flue without our permission. Otherwise, it may cause a loss of eyesight and/or skin lesion. Consult us if there is a need for removal.
 - O₂ analyzer for high temperature and instrument air purge version O₂ analyzer use the Class 3B laser elements. When anyone enters into the flue, this product is regarded as a Class 3B product. In this case, safety measures are required; for example, an entrance detection system, an interlock that stops radiation of laser beam, etc. Consult us for details.

Information in this catalog is subject to change without notice.
Read the instruction manuals thoroughly before using the products.



Gate City Ohsaki, East Tower, 11-2, Osaki 1-chome, Shinagawa-ku, Tokyo 141-0032, Japan
Phone: +81-3-5435-7111
www.fujielectric.com
www.fujielectric.com/products/instruments/