

Uninterruptible Power Supply Systems UPS7300WX-T3U



The innovative UPS7300WX-T3U UPS pushes advanced technology and intelligent design to a new level

- Efficiency greater than 96% at loads as low as 25%
- Handles up to .7 leading power factor loads without de-rating
- Selectable High Efficiency (HE) Mode increases efficiency to as high as 99% under normal conditions
- Outstanding voltage and frequency regulation (Voltage +/-1%; Frequency +/-0.01%)
- 100% unbalanced load capability
- Voltage regulation for 100% load steps <3%, without utilizing batteries
- Overload capacity 150% for 1 minute, 125% for 10 minutes

Energy Prowess Meets Forward Thinking

- Fuji Electric's exclusive AT-NPC Topology using RB-IGBT Technology in both Rectifier and Inverter
- Reduces component count in the power section, thereby reducing losses for higher efficiency

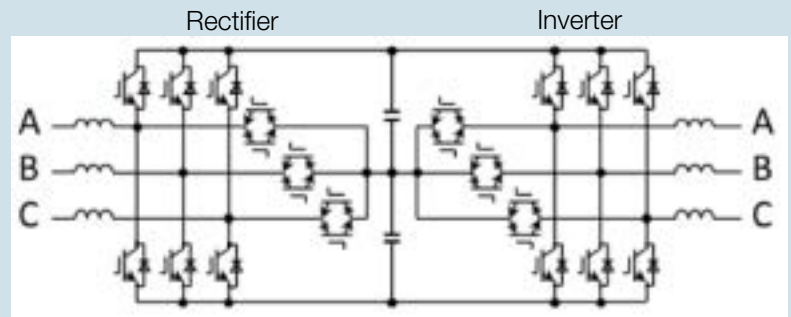

Use of RB-IGBT's reduces parts count and switching losses

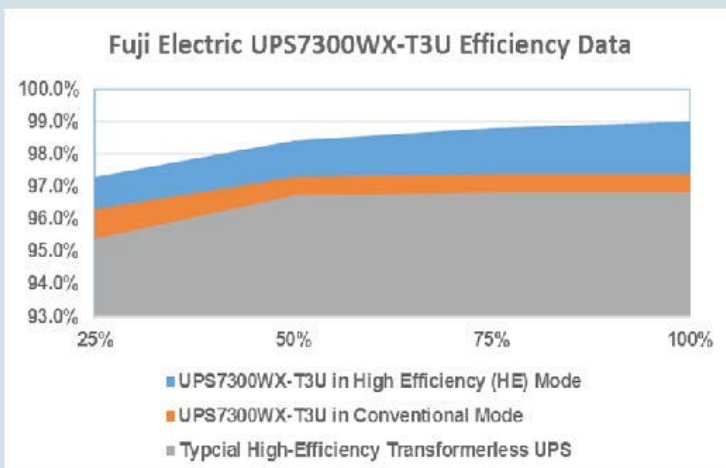

Built to Last

- Redundant fans standard
- Fully maintainable and repairable with only front access required
- Comprehensive manageability via large colortouch screen and at-a-glance status LEDs
- Three-Year warranty covers parts and labor

Specifications

CAPACITY (one UPS module)	225 kVA	300 kVA	330 kVA (max load)
Topology	Online Double Conversion with RB-IGBT Technology		
AC INPUT			
Voltage / Phases	480 VAC / 3-phase, 3-wire (Y) + Ground		
Voltage Range	-30% to +10%		
Frequency / Range	60 Hz / ±10%		
Power Factor	> .99		
Current THD	< 5%	< 5%	< 3%
Current (Nominal)	279 A	372 A	410 A
Current (Maximum)	307 A	399 A	439 A
BYPASS			
Voltage / Phases	480 VAC / 3-phase, 3-wire (Y) + Ground		
Frequency / Range	60 Hz / ±1% - ±5%, selectable		
BATTERY			
Voltage (Nominal / Rated)	480 VDC / 545 VDC (240 cells, 2.27 V per cell)		
Max Charging Current	88 A		
AC OUTPUT			
Voltage / Phases	480 VAC, 3-phase, 3-wire (Y) + Ground		
Voltage Regulation	< ±1%		
Frequency / Regulation	60 Hz / < ±.01% (in free-running mode)		
Power Factor (Rated)	1.0		
Power Factor Range	.7 leading to .7 lagging without derating		
Voltage THD	< 2% (linear load); < 5% (non-linear load)		
Transient Voltage Regulation	< 3% (at 100% load step)		
Overload Capacity	125% for 10 minutes; 150% for 1 minute		
Current (Nominal)	271 A	361 A	397 A
ENVIRONMENTAL			
Audible Noise	≤ 75 dBA (1m in front of cabinet)		
Operating Temperature	32 to 104 °F (0 to 40 °C)		
Storage Temperature	-13 to 131 °F (-25 to 55 °C)		
Relative Humidity	5 to 95% (Non-condensing)		
Altitude	≤ 6560 ft (2000 m)		
EFFICIENCY			
100% Load in High Efficiency Mode	98.8%	98.9%	99.0%
EnergyStar Avg (Online Mode)	96.6%	96.9%	97.1%
100% Load	97.4%	97.3%	97.3%
75% Load	97.3%	97.4%	97.4%
50% Load	96.9%	97.2%	97.3%
25% Load	95.3%	96.1%	96.3%
DIMENSIONS			
Width	59.1 in (1500 mm)		
Depth	32.7 in (830 mm)		
Height	79.5 in (2020 mm)		
Weight	2425 lbs (1100 kg)		
Ingress Rating	NEMA 1 (IP20)		
STANDARDS			
Safety	UL 1778 5th Edition; CSA 22.2 No.107.3-14 3rd Edition		
EMC	IEC 62040-2, Category C3		
Environmental	EnergyStar(Certified as Ver. 1.1, 2017)		
Seismic	OSHDP Certified		