

Instruction Manual

Fuji Electric Co., Ltd.



DIGITAL THERMOSTAT (Replacement for PAS3)

Model : PXR3

Global Sales Section
Instrumentation & Sensors Planning Dept.
1, Fuji-machi, Hino-city, Tokyo 191-8502, Japan
http://www.fujielectric.com
Phone: +81-42-514-8930 Fax: +81-42-583-8275
http://www.fujielectric.com/products/instruments/

Fuji Electric Co., Ltd.

INP-TN2PXR361-E

Thank you for your purchasing "Fuji DIGITAL THERMOSTAT." Please check that the product is exactly the one you ordered and use it according to the following instructions. (Please refer to a separate operation manual for details.) Dealers are cordially requested to ensure the delivery of this Instruction Manual to hands of the end-users.

NOTICE

The contents of this document may be changed in the future without prior notice. We paid the utmost care for the accuracy of the contents. However, we are not liable for direct and indirect damages resulting from incorrect descriptions, omission of information, and use of information in this document.

Model Code for Digital Thermostat PXR3 (Replacement for PAS3)

Input signal	Specification		Model code
	Input range	Alarm points	
Thermocouple (K)	0 to 1200 °C	1 point	PXR3TAY2-0V061
		2 points	PXR3TAY2-1V061
Thermistor	0 to 100 °C	1 point	PXR3HAY2-0V061
		2 points	PXR3HAY2-1V061

Specification

Power voltage:	100 V (-15%) to 240 V (+10%) AC, 50/60 Hz
Power consumption:	6VA or less (100V AC), 8VA or less (220V AC)
Alarm output (Max. 2 points):	Relay contact (SPST contact) 220V AC / 30V DC 2A (resistive load)
Operating ambient temperature:	-10 to 50°C, 90%RH or less (no condensation)
Preservation temperature:	-20 to 60°C
Thermistor sensor:	Allowable deviation/±2°C or less, constant value B/3390K±1%, resistance/6kΩ (0°C)
Conformity:	UL, CE marking

Unpacking

Before using the controller, check if the type and specifications are as ordered. Check that all of the following accessories are included in the package box.

- Digital thermostat main unit 1
 - Instruction manual 1
 - Mounting adapter 1
 - Watertight packing 1
 - Thermistor sensor (only for the type that the input signal is thermistor)
- Note: The provided thermistor sensor is the sensor dedicated to this equipment.

Related Documents

For more information, refer to the following documents:

Contents	Title	No.
Operation method	DIGITAL THERMOSTAT OPERATION MANUAL	TN5A2886-E
Details of alarm functions	PXR3 Supplementary Manual on Alarm Function	TN5A3203-E

Safety Precautions

Read before use

Before using this product, the user is requested to read the following precautions carefully to ensure the safety. Safety precautions must be taken by every user to prevent accidents. The safety requirements are classified into "warning" and "caution" according to the following interpretations:

Warning	Suggesting that the user's mishandling can result in personal death or serious injury.
Caution	Suggesting that the user's mishandling can result in personal injury or damage to the property.

WARNING Over-temperature Protection

"Any control system design should take into account that any part of the system has the potential to fail". "The most dangerous condition of the system equipped with this product is continued heating, and the machine should be designed to automatically stop heating even if alarm is not issued at the time of failure of this product or due to any other reason".
The following are the most common cases where continued heating cannot be detected with this product.
1) Failure to issuing an alarm even when this product fails
2) Disengagement of the temperature sensor from the system
3) A short circuit in the thermocouple wiring
In any application where physical injury or destruction of equipment might occur, we recommend the installation of independent safety equipment, with a separate temperature sensor, to disable the heating circuit in case of overheating.
Digital thermostat alarm signal is not designed to function as a protective measure in case of product failure.

1. Warning

1-1. Installation and wiring

- This product designed to be installed at the conditions shown in the below table.

Operating temperature	-10 to 50°C
Operating humidity	90%RH or less (Non condensation)
Installation category	II
Pollution degree	2
Recommended fuse	250 V AC, 0.1 A, Time-delay fuse (100-240 V AC)
Operating environment	Indoor

- Be sure to provide a basic insulation (For example, use a transformer that has a basic insulation or higher degree of insulation). The basic insulation requires a clearance at least 1.5 mm and a creepage of at least 3.0 mm. If such insulation is not provided, EN61010 safety compliance may become invalid.

About safety standard

Please observe the following instructions to meet the requirements of safety standard. Failure to observe these instructions violates safety standards. (This product is not safety equipment.)

- Install a recommended fuse, which is specified in the instruction manual, between the external main power (mains circuit) and this equipment.
- Do not connect a Safety Extra Low Voltage (SELV) circuit directly to the input terminals. If you connect a SELV circuit to any of the input terminals, ensure to provide a basic insulation between them. For example, use a transformer that has a basic insulation or higher degree of insulation. The basic insulation requires a clearance at least 1.5 mm and a creepage of at least 3.0 mm.
- Be sure to install an appropriate external protective circuit to prevent excessive temperature rise etc.
- When performing wiring work, be sure to turn the power off and to wear protection gloves or safety glasses, to prevent an electric shock.
- Set an appropriate parameter for the type of the input to be connected.
- Do not use this equipment for the measurement of circuits which fall under measurement categories II, III, or IV.
- Do not use this equipment for measurement of signals to which a voltage over 30 Vrms or over 60 Vdc is applied.
- Attach the terminal cover to prevent an electric shock. Before removing a terminal cover, turn off all the power.

- If the voltage exceeds 50 V DC, add a basic insulation between all the terminals and the ground terminal.
- If there is a danger of a serious accident resulting from a failure or a defect in this unit, provide the unit with an appropriate external protective circuit to prevent an accident.
- The unit is supplied without a power switch and fuses. Add a power switch and/or fuse if needed. Make wiring so that the fuse is placed between the main power supply switch and this product. (Main power supply: 2 pole breaker, fuse rating: 250V, 1A)
- A power switch or a circuit breaker should be installed within the power supply facility.
- A power switch or a circuit breaker should be properly installed within easy reach of an operator.
- A power switch or a circuit breaker should be identified as the one for this product.
- Electrical wiring must be made by the qualified personnel only and in accordance with your local and national standards.
- When wiring the power supply terminal, use vinyl insulated 600 volt cable or equivalent.
- To avoid the damage and failure of this product, supply the power voltage fitting to the rating.
- To avoid an electric shock and this product failure, do not turn ON the power before all wiring is completed.
- Be sure to check that the distance is kept to avoid electric shock or firing before turning the power ON.
- Keep away from terminals while the circuit is energized in order to avoid an electric shock and a malfunction.
- Never attempt to disassemble, fabricate, modify, or repair this unit because tampering with the unit may result in a malfunction, electric shock, or a fire.
- A relay has a limited life. When an output relay contact comes to the end of its life, it might remain opened or closed. Use a protective circuit outside this product for safety.
- Read this instruction manual thoroughly before use.

1-2. Maintenance precautions

- Be sure to turn off the power before this product is installed or removed in order to avoid an electric shock, malfunction, and fault.
- Regular maintenance is recommended for a longer service life of this controller. Some parts of this controller have a limited life span, or they will be deteriorated with the lapse of time.
- This product including accessories has one-year warranty if it is properly used.

2. Caution

2-1. Cautions on installation

Avoid the following places for installation.

- a place where the ambient temperature may reach beyond the range from -10 to 50°C while in operation.
- a place where a change in the ambient temperature is so rapid as to cause condensation.
- a place where corrosive gases (sulfide gas and ammonia gas, in particular) or combustible gases are emitted.
- a place where the unit is subject directly to vibration or shock. (vibration or shock may cause malfunction of the output relay.)
- a place exposed to water oil, chemicals, steam and vapor.
(if immersed with water, take the inspection by sales office to avoid an electrical leakage and firing)
- a place where the unit is exposed to dust, salt air, or air containing iron particles.
- a place where the unit is subject to interference with static electricity, magnetism, and noise.
- a place where the unit is exposed to direct sunlight.
- a place where the heat may be accumulated due to the radiation of heat.
- a place where the ambient humidity may reach beyond 90% RH while in operation.

About EMC standard

- This equipment is designed as a class A equipment that is for industrial locations. Do not use this equipment in domestic establishment such as residential areas, or it may cause radio interference. If you unavoidably use this equipment in domestic locations, take adequate measures on the outside of the equipment to reduce radio interference.
- Under the requirement of EMC standard, the maximum length of external cable including a sensor to be connected to this equipment is 30 m.

2-2. Cautions on installation on panel

- Insert the mounting adapter (accessory) from the rear side until the main unit is securely fit into the panel. If there should be a play, tighten two screws lightly until the play is eliminated. (Do not tighten the screws excessively because the mounting adapter can be removed from the stopper by the force.)
- The front panel meets NEMA 4X (equivalent to IP66) requirements. To ensure the waterproofness between the instrument and the panel, use packings that are provided as accessories in the following manner: (The improper fitting of packings will ruin the waterproofness.)
① As shown in Figure 1, fit a packing to the case of the unit and then insert the PXR3 in the panel.
② As shown in Figure 2, tighten the screws of the mounting adapter so that no gaps are given between the front panel of the thermostat, packing, and the panel.
Check that there are no deviation and deformation of packing as shown in Fig.3.
- If panel strength is weak, it may generate a gap between the packing and the panel, thus impairing water resistance.

Installation

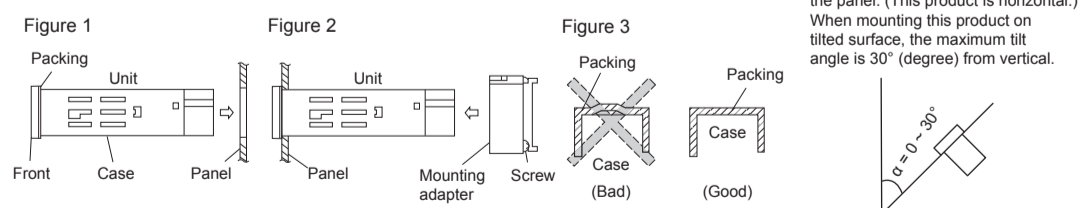

- **Caution** Don't block the openings around this product, or radiation effect will be reduced.
- Don't block the ventilation openings at the top of the terminal block.

2-3. Precautions in wiring connection

- For the thermocouple sensor type, use thermocouple compensation wires for wiring.
- Keep input lines away from power line and load line to avoid the influence from noise induced.
- For the input and output signal lines, be sure to use shielded wires and keep them away from each other.
- If a noise level is excessive in the power supply, the additional installation of an insulating transformer and the use of a noise filter are recommended.
Make sure that the noise filter is installed to a place such as a panel that is properly grounded. The wiring between the noise filter output terminal and the instrument power supply terminal should be made as short as possible. None of fuses or switches should be installed to the wiring on the noise filter output side because the filter effect will be degraded by such a installation.
- A better anti-noise effect can be expected by using stranded power supply cable for the instrument. (The shorter the stranding pitch is, the better the anti-noise effect can be expected.)
- A setup time is required for the alarm output when the power is turned on. If the alarm output is used as a signal for an external interlock circuit, use a delay relay at the same time.
- Use the auxiliary relay since the life is shortened if full capacity load is connected to the alarm output relay.
- If inductive load such as magnetic switches connected as a alarm output load, it is recommended to use surge absorber to protect a contact from switching surge and keep a longer life.

Recommended specification of surge absorber

Voltage	Varistor voltage rating
100V	240V
200V	470V

Where to install: Between contacts of the alarm output.

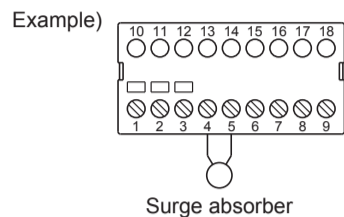

2-4. Requirement for key operation/operation in abnormalities

- The indication of "UUUU" or "LLLL" appears if the input disconnection occurs. Turn off the power before replacing sensor.
- When you change the alarm setpoint or other parameter values, wait for at least five seconds before turning off the power.
- After setting the alarm, be sure to carry out a test operation to check if the alarm is properly set and works properly.

2-5. Others

- Do not use organic solvents such as alcohol and benzene to wipe this controller. Use a neutral detergent for wiping this product.
- Do not bring any mobile phone close to the main unit (50 cm). Malfunction will occur.
- Noise may be produced if this equipment is brought close to a radio. Use this equipment as fully spaced apart from radios.

Operation Procedure

<Reference items>	<Description>	<Remarks>
Confirming type specification	• Confirming that the delivered product is equal to the ordered one.	
1 Installation	• Outline dimensions • Panel cutout dimensions • Mounting method on the panel	• Read "Safety Precautions"
2 Wiring	• Terminal connection diagram	• Read "Safety Precautions"
Power on		• To start the operation, wait for about 15 minutes after the power-on for warm up.
3 Display and Keys		
4 Operation	• Basic operation method • Set value change method	
5 Display Mode Switching		
6 Alarm Code and Range Code	• List of input/alarm codes	
7 List of Parameters	• Names and functions of parameters	
8 Alarm Functions		
Operation		
9 Error Codes	• Display when abnormal	• Limited Warranty

1. Installation

Outline and Panel Cutout Dimensions

- Outline dimensions (Unit : mm)

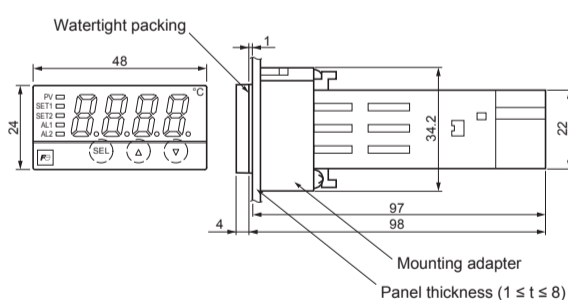

- Panel cutout dimensions (Unit : mm)

For separate mounting (Unit: mm)

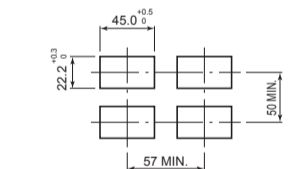

For mounting close together

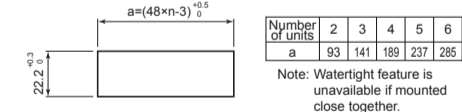

2. Wiring

Terminal Connection Diagram (100 to 240 V AC)

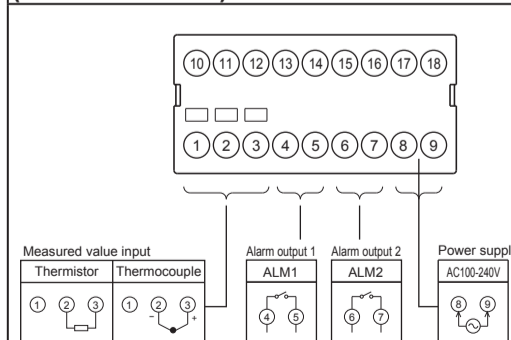

- Note 1) Check the power supply voltage before installation.
Note 2) Tighten the terminal screw securely with fastening torque of 0.4N·m.

Wiring Material

- Wire
Gauge: AWG28 (0.1mm²) to AWG16 (1.25mm²)
Strip-off length: 5 to 6 mm
 - Rod terminal
Dimension of exposed conductor section: 2×1.5 mm or smaller
Length of exposed conductor section: 5 to 6 mm
- Recommended terminals:
Manufacturer: NICHIFU CO., LTD.
Model: TMEV TC-0.3-9.5
TMEV TC-1.25-11s
TGN TH-0.75N
- Manufacturer: DAIDO SOLDERLESS TERMINAL MFG. CO., LTD.
Model: AVA-1.25L
BVA-1.25L
- *If the exposed conductive part is longer than above requirements, cut the excess.
- Note:** To prevent disconnection or short circuit, never use the wire other than the one stated above, and make sure to insert it toward the back of the terminal block. Fastening torque: 0.4N·m

3. Display and Keys (Read before use)

Name of Functional Parts and Functions

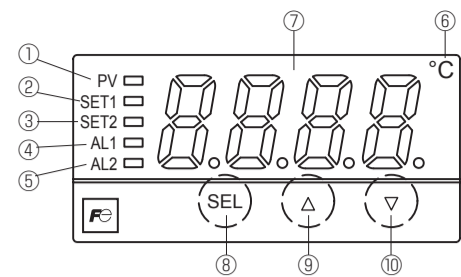

Display/Indication

No.	Name	Function
①	Process value (PV) indicator	Lights in green when PV is displayed.
②	Alarm 1 set value (SET1) indicator	Lights in green when the alarm 1 set value is displayed.
③	Alarm 2 set value (SET2) indicator	Lights in green when the alarm 2 set value is displayed.
④	Alarm 1 (AL1) indicator	• Lights in green when the alarm 1 occurs. • Blinks during on-delay.
⑤	Alarm 2 (AL2) indicator	• Lights in green when the alarm 2 occurs. • Blinks during on-delay.
⑥	Unit indicator	Shows the temperature unit.
⑦	7-seg 4 digit LED	• In operation mode (level 1): displays PV, SET1, or SET2 • In parameter setting modes (level 2, 3, or 4): displays a parameter name or a parameter value • Upon error: shows an error code. (See "9. Error codes".) *PV and alarm set values can be set in increments of 1°C.

Setting keys

No.	Name	Function
⑧	Select key	Used for switching of display between process value and alarm set value, level move, switching to parameter setting mode and for data registration.
⑨	Up key	• Used for parameter shifting (returning) or data changing (increasing). • The numerical value is increased by pressing the key once. The numerical value keeps on increasing by pressing the key continuously.
⑩	Down key	• Used for parameter shifting (to next) or data changing (decreasing). • The numerical value is decreased by pressing the key once. The numerical value keeps on decreasing by pressing the key continuously.

4. Operation

Parameter setting mode (level 2, level 3, level 4)

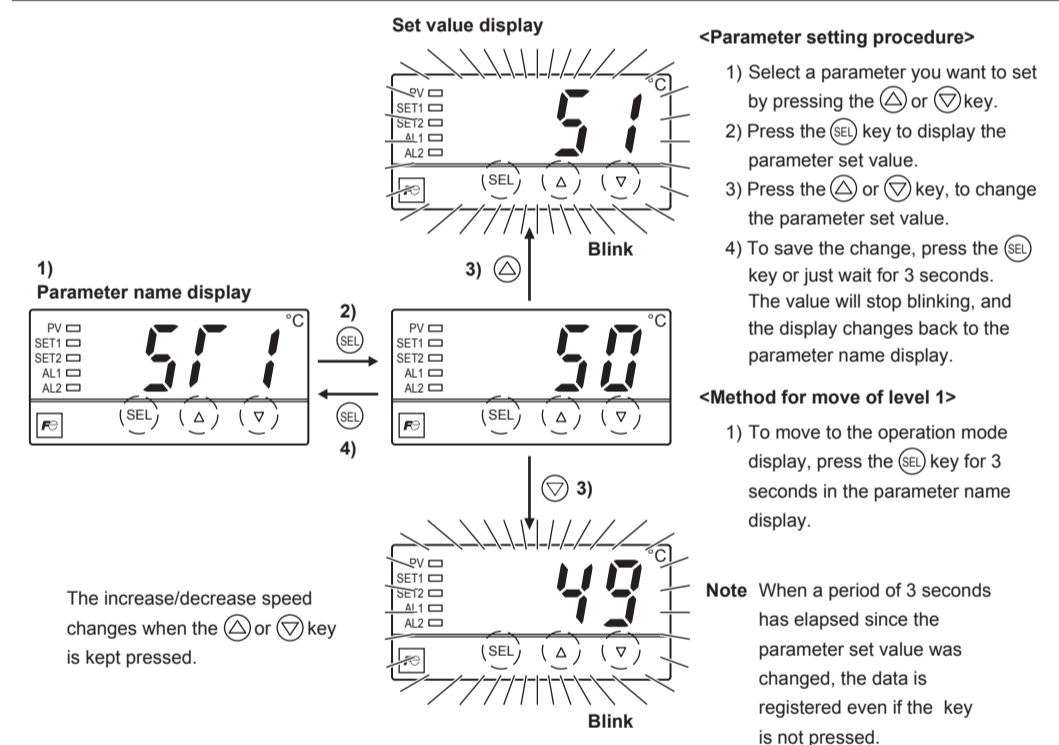

The increase/decrease speed changes when the Δ or ∇ key is kept pressed.

5. Display Mode Switching

Operation mode (level 1)

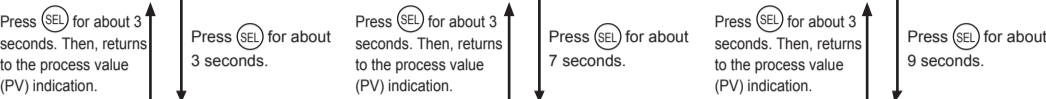
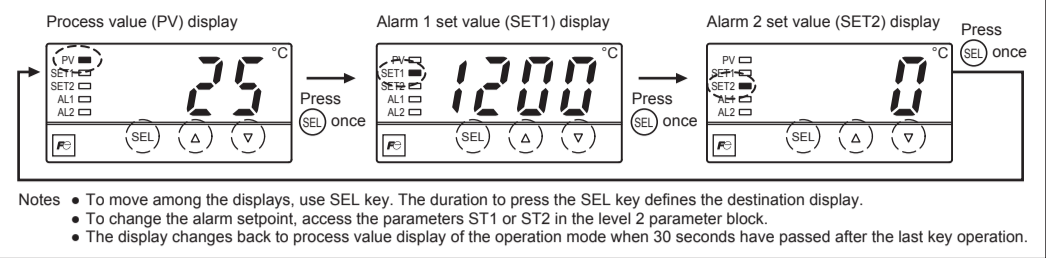

Level 2 parameter block

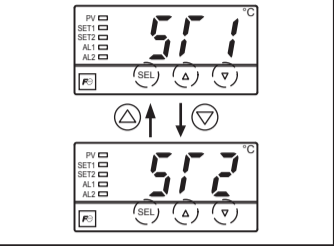

Level 3 parameter block

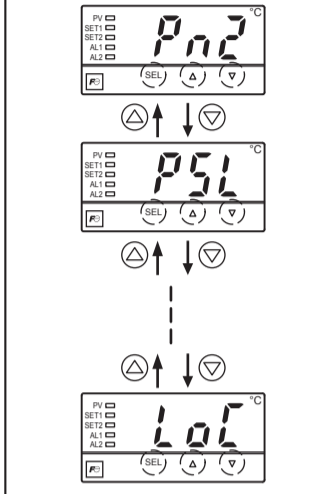

Level 4 parameter block

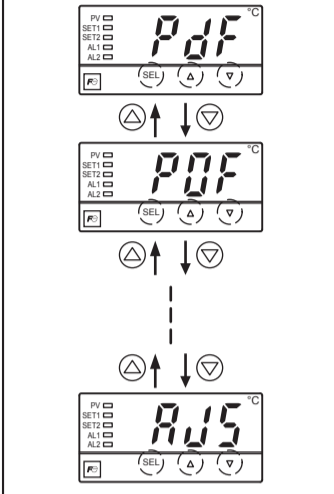

6. Alarm Codes and Range Codes

[Table 1] Alarm action type code

Code of PA1 and 2	Alarm type	Set value	Hold function	Relay operation at alarm	Action diagram
0	No alarm	If your PXR3 has two alarms but you want to use only one alarm, set the other alarm to "0".			
1	Upper limit	Absolute value	Without	Relay energization	
2	Lower limit	Absolute value	Without	Relay energization	
3	Upper limit	Absolute value	With	Relay energization	
4	Lower limit	Absolute value	With	Relay energization	
5	Upper limit	Absolute value	Without	Relay de-energization	
6	Lower limit	Absolute value	Without	Relay de-energization	
7	Upper limit	Absolute value	With	Relay de-energization	
8	Lower limit	Absolute value	With	Relay de-energization	

Note: Be sure to power-cycle PXR3 after you change the alarm type.

How to read activation diagram

■ area: Range in which the AL1 or the AL2 indicator lights.
 ■ area: Range in which the alarm relay is energized
 △ point: Alarm set value
 The horizontal represents PV.

[Table 2] Input range codes

Input signal	Code of Pn2	Range (°C)	Indication accuracy
Thermocouple	J	0 to 800	±0.5% FS ±1digit±1°C
	K	0 to 1200	±0.5% FS ±1digit±1°C
	R	0 to 1600	±0.5% FS ±1digit±1°C
	T	0 to 400	±0.5% FS ±1digit±1°C
	E	0 to 600	±0.5% FS ±1digit±1°C
Thermistor	PB-36	0 to 100	±4°C

- Notes
- Correct display is not made in the range of 0 - 500°C of R thermostat.
 - It is not permitted to make switching between thermistor input and thermocouple input. (It is fixed depending on what was specified at the time of purchase.)
 - If the input signal was changed, the measuring range should be changed to a value that corresponds to the input signal. (Set PSL at 0 and set PSU at the upper limit value of the measuring range.)
 - The accuracy of indication of the thermocouple does not include the reference junction compensation accuracy (±1°C).
 - The accuracy of indication of thermistor input does not include the accuracy of the sensor.

7. List of parameters

Level	Parameter indication	Parameter name	Function	Default setting	Remarks		
Level 2	ST1	57.1	Alarm 1 set value setup	Set the alarm 1 activation value. It may be set within the input range.	100%	Note 1 Table 2	
	ST2	57.2	Alarm 2 set value setup	Set the alarm 2 activation value. It may be set within the input range.	0%	Note 1 Table 2	
Level 3	Pn2	Pn2	Input type	Selection of input type		Note 8	
	PSL	PSL	Range lower limit setup	Setup of lower limit of the input range (set range: -1999 to 9999)	0		
	PSU	PSU	Range upper limit setup	Setup of upper limit of the input range (set range: -1999 to 9999)		Note 9	
	PA1	PA1	Alarm type 1	Select the type of alarm activation. (set range: 0-8)	1	Table 1	
	PA2	PA2	Alarm type 2		2	Table 1	
		HY1	HY1	Alarm 1 hysteresis width	Set the ON/OFF hysteresis width of the alarm output. (set range: 0-110%FS of the input range)	1	Note 2
		HY2	HY2	Alarm 2 hysteresis width		1	Note 2
		Pd1	Pd1	Alarm 1 ON delay time	Set ON delay of the alarm output. (set range: 0-120 seconds)	0	
		Pd2	Pd2	Alarm 2 ON delay time		0	
		brn	brn	Burn-out direction	Set the swinging direction at the time of burn-out. (set range: upper limit = H, lower limit = L)	H	
	oPd	oPd	Power ON delay time	Setup of power ON delay time power ON delay. Delay time until output inhibition is canceled after power ON (set range: 0-120 seconds)	0		
	LoC	LoC	Setup lock	Select whether parameter setup change is permitted or not. LoC = 0: Setup change is permitted for all parameters. LoC = 1: No setup change is permitted for all parameters. LoC = 2: Alarm set value 1 (ST1) and alarm set value 2 (ST2) only may be set.	0		
Level 4	PdF	PdF	Input filter time constant	Set the time constant. (set range: 0.0-90.0 seconds) Setting is available in 0.5 seconds increments. Setting to "0.0" turns off the filter.	5.0		
	POF	POF	PV offset	Shift the display of the process value (PV). (set range: -10-10%FS of the input range)	0	Note 1, 2	
	AJO	AJO	User ZERO adjustment	Shift the input ZERO side. (set range: -50-50%FS of the input range)	0	Note 1, 2	
	AJS	AJS	User SPAN adjustment	Shift the input SPAN side. (set range: -50-50%FS of the input range)	0	Note 1, 2	

- Notes
- If the unit of setup of a parameter is engineering value or deviated engineering value, the value of such a parameter changes accompanying change to PSL and PSU. (Indicated by □.)
 * Values of input range 100% = PSU, input range 0% = PSL
 - FS (full scale) means the value of PSU - PSL. (Example: 50% FS = $(1200 - 0) \times \frac{50}{100}$, when PSL = 0 and PSU = 1200)
 - Parameters indicated with □ do not appear on the versions that have only one alarm.
 - The accuracy of alarm delay time and of power ON delay time is less than 1 second.
 - A difference of 1°C may arise between the indication and the alarm output depending on the range setup. (Example: If the alarm set value is 200°C, an alarm occurs when the indication is 200°C in some cases, but an alarm occurs when the indication is 201°C in other cases.)
 - There are cases where over-range (UUUU) or under-range (LLLL) display is not made, if a large value is set as a PV offset, user zero or user span. Be careful.
 - Parameters indicated by □ are not displayed on the thermistor input version.
 - Input type code: thermocouple: 3, thermistor: 8
 - The range upper limit: thermocouple: 1200, thermistor: 100

8. Alarm functions

1) Kinds of alarm

Absolute value upper limit alarm or absolute lower limit alarm is available. (For details, see Table 1 Alarm action type codes.)

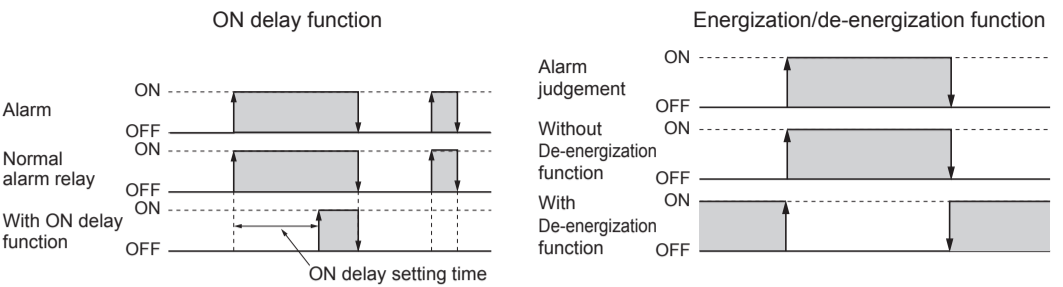

2) Function of alarm

Note: We offer the "Supplementary Manual on Alarm Function". Contact us if you need it.

No.	Function name	Function	Parameters to set
①	Hysteresis function	Allows you to set the hysteresis (dead band) for alarm.	Alarm1 : HY1 Alarm2 : HY2
②	Alarm ON delay function	Allows you to set the delay time after which the alarm action starts when the alarm condition is satisfied.	Alarm1 : Pd1 Alarm2 : Pd2
③	Energization/de-energization function	Allows you to select either to energize or to de-energize the relay output upon alarm. (See Table 1 Alarm action type code.)	Alarm1 : PR1 Alarm2 : PR2
④	Power ON delay function	Allows you to set the delay time during which the alarm is not activated after the power is turned on.	oPd

Point What is alarm with hold?

The alarm is not turned ON immediately even when the measured value is in the alarm band. It turns ON when it goes out the alarm band and enters again.

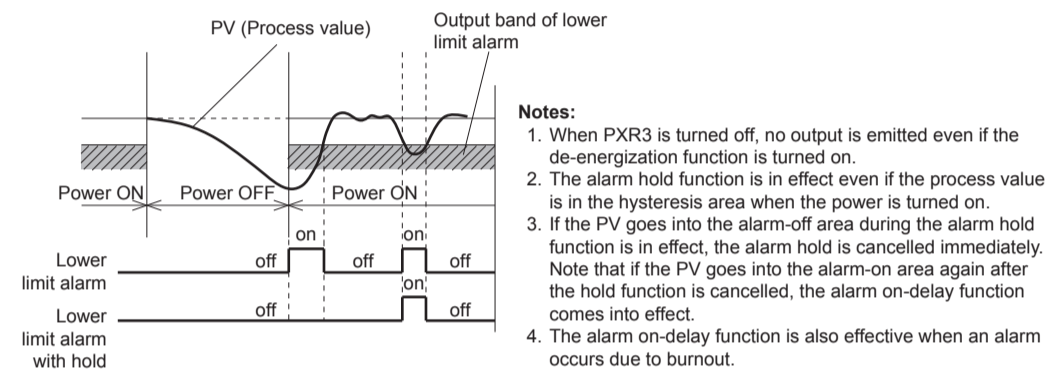

Notes:

- When PXR3 is turned off, no output is emitted even if the de-energization function is turned on.
- The alarm hold function is in effect even if the process value is in the hysteresis area when the power is turned on.
- If the PV goes into the alarm-off area during the alarm hold function is in effect, the alarm hold is cancelled immediately. Note that if the PV goes into the alarm-on area again after the hold function is cancelled, the alarm on-delay function comes into effect.
- The alarm on-delay function is also effective when an alarm occurs due to burnout.

9. Error Codes

Error indications

If any of the following error code appears, immediately remove the cause of the error, and then power cycle PXR3.

Error code	Possible cause	Alarm output
UUUU	① Thermocouple burnt out. ② PV value exceeds the range upper limit by 5% FS.	<Case of upper limit alarm setup> ① When burn-out direction (brn) is set at lower limit (L) OFF ② When burn-out direction (brn) is set at upper limit (H) ON <Case of lower limit alarm setup> ① When burn-out direction (brn) is set at lower limit (L) ON ② When burn-out direction (brn) is set at upper limit (H) ... OFF
LLLL	① PV value is below the range lower limit by 5%FS. ② Thermistor sensor burnt out.	
Eerr	Incorrect range setting (PSL/PSU)	OFF
FALF	Device failure	Unfixed *Stop using the device immediately, and contact us.

10. Limited warranty

1. Scope of warranty

If malfunction occurs in the period of warranty due to Fuji Electric, the malfunctioning parts are exchanged or repaired for free. However, in the case where an engineer needs to visit your place for replacement or repair, you will be charged our call out fee. Please note that upon repair or replacement of failed parts we cannot provide commissioning and/or readjustment for the whole system that includes our product. The warranty does not apply to the following cases:

- The malfunction occurs due to inappropriate conditions, environment, handling or usage that is not instructed in a catalog, instruction manual or user's manual
- Factors that do not originate in the purchased or delivered product
- The malfunction is caused by other devices or software design that does not originate in Fuji Electric products
- The malfunction occurs due to an alteration or repair that is not performed by Fuji Electric
- Inappropriate maintenance or replacement of expendable parts listed in the instruction book or the catalog
- Factors that were not foreseeable by the practical application of science and technology at the time of purchase or delivery
- The malfunction occurs because the product is used for an unintended purpose
- The malfunction occurs due to a disaster or natural disaster that Fuji Electric is not responsible for

2. Exclusion of liability for loss of opportunity

Regardless of the time period of the occurrence, the amount of compensation assumed by Fuji Electric for damage, excluding which is caused by intentional acts or acts of gross negligence or illegal act by Fuji Electric, shall not exceed the amount stipulated in the contract with the customer. Fuji Electric is not liable for the damage to products that were not manufactured by Fuji Electric, incidental damages or consequential damages, or damage caused due to special situations regardless of whether it was foreseeable or not, or passive damages such as opportunity loss or lost profits of the purchaser.

3. Scope of application

This equipment must be used under the following conditions:

- the use of the equipment incurs no risk of a serious accident even if a failure or malfunction occurs on the equipment, and
- in case of product failure or malfunction, safety measures such as redundant design, prevention of malfunction, fail safe setting, foolproof mechanism are provided outside of the equipment by the user.

The product described in this document is designed and manufactured as a general-purpose product for general industrial applications.

The warranty does not apply to the following cases:

- for the use not described in or beyond the conditions or environment specified in the instruction manual or the user manual,
- for the use which has large influence on publicity including nuclear power and other power generation, gas, and/or water,
- for the use in which safety is especially required, because it may seriously affect railroads, vehicles, combustion equipment, medical equipment, entertainment devices, safety equipment, defense equipment, and/or human lives and property.

However, we will study the possibility of application of the equipment for the above use, if the user limits the usage of it and agrees to require no special quality. Please consult us.