

NDIR Gas Analyzer

ZPA, ZPB, ZPG

Outstanding Sensitivity and Stability

- ✓ 0–5 ppm low-range measurement (ZPG)
- ✓ Continuous and simultaneous measurement of up to 5 components (ZPA, ZPB)
- ✓ Excellent zero-point stability: $\pm 0.5\%$ FS per week (ZPB, ZPG)
- ✓ Easy-to-see LCD



ZPA



ZPB



ZPG

Long-term stability for a wide range of



Single-Beam NDIR Sensor

Repeatability: $\pm 0.5\%$ FS or better Simple structure for ease of maintenance

Principle

The mass flow sensor measures the amount of infrared absorbed in the measurement cell.

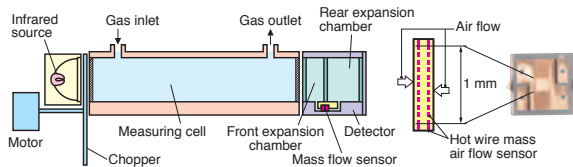

Mass flow sensor

Converts the amount of infrared absorption into electrical signals. Excellent noise resistance thanks to the low impedance sensor. The absence of moving parts makes the device resistant to vibration and semi-permanently usable.

Sample-Switching Method

- Low-level CO₂ and CO: 0–5 ppm
- Long-term superior stability: zero drift $\pm 0.5\%$ FS per week

The analyzer has a motor-operated valve that switches between the sample gas and the reference gas (zero gas) at a certain cycle. This allows the analyzer to keep the zero point accurate and to deliver stable measurement.

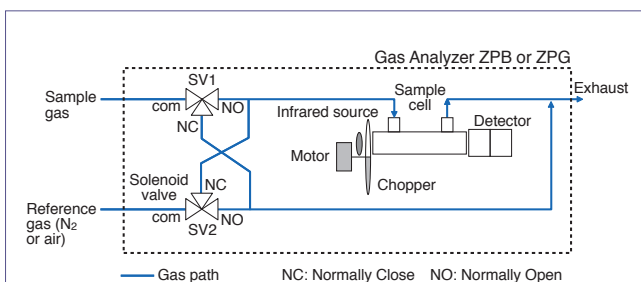

Because the single-beam system is susceptible to temperature change and contamination in the measuring cell, the measurement range in this method is usually 0–100 ppm at the best. By using the sample-switching method, ZPB and ZPG can deliver stable measurement for the range as low as 0–5 ppm.

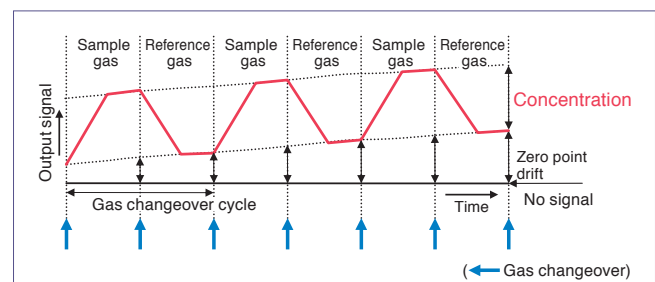

In the sample-switching method, the zero point drift is ignored and the measured values exactly correspond to the concentration difference between the sample gas and the reference gas. Thus, the analyzer can deliver accurate and stable measurement even in the range close to the zero point.

concentrations

Applications

- Refuse incineration plants
- Boiler equipment
- Incinerators, industrial furnaces
- Air separation plants (ZPG)



ZPG: low-concentration measurement

Versatile functionality

Standard functions Optional functions

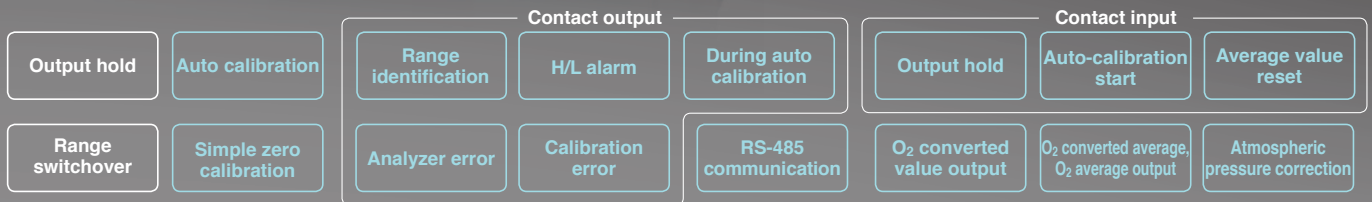

Tolerant to Interference

Interference from moisture and other gases is reduced by the compensation function and the sample-switching method (ZPB and ZPG).

Interference gas	CO ₂ analyzer	CO analyzer	CH ₄ analyzer	SO ₂ analyzer	NO analyzer
CO 1000 ppm	≤ ±1% FS	–	≤ ±1% FS	≤ ±1% FS	≤ ±1% FS
CO ₂ 15%	–	≤ ±1% FS* ¹	≤ ±1% FS	≤ ±1% FS	≤ ±1% FS* ²
H ₂ O saturation at 20°C	≤ ±1% FS	≤ ±1% FS* ³	≤ ±1% FS	–	–
H ₂ O saturation at 2°C	–	≤ ±2% FS	–	≤ ±2% FS	≤ ±2% FS
CH ₄ 1000 ppm	≤ ±1% FS	≤ ±1% FS	–	≤ 20 ppm	–

*1: 0–200 ppm range: ≤ 2% FS

*2: 0–500 ppm range: ≤ 2% FS

*3: 0–500 ppm range: ≤ 2% FS

Interference for 0–200 ppm range may be greater than 2.0% FS depending on conditions.

Easy-to-See LCD

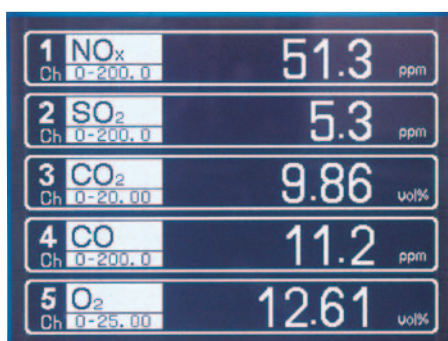

Atmospheric Pressure Compensation (option)

The adverse effect by fluctuations in atmospheric pressure is greatly eliminated.

ZPG Application Example

Measurement of low-level CO₂ and CO in air separating plants

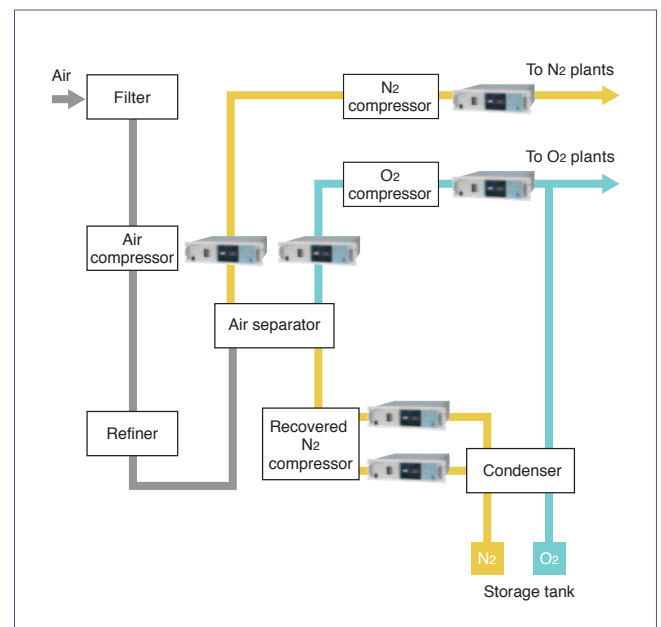

Single beam

5 components max.

NO

SO₂

CO₂

CO

CH₄

O₂

Standard type ZPA



	Min.	Max.
NO	0 ... 200 ppm	0 ... 5000 ppm
SO ₂	0 ... 200 ppm	0 ... 10 vol%
CO ₂	0 ... 100 ppm	0 ... 100 vol%
CO	0 ... 200 ppm	0 ... 100 vol%
CH ₄	0 ... 500 ppm	0 ... 100 vol%
O ₂	0 ... 5 vol%	0 ... 100 vol%

The O₂ ranges above are for the built-in magnetic analyzer.

System configuration example

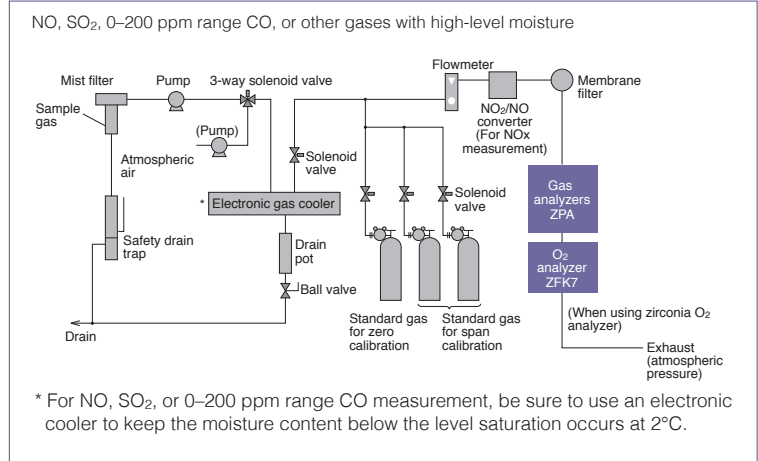

Single beam

Sample switching

5 components max.

NO

SO₂

CO₂

CO

O₂

Drift-less type ZPB



	Min.	Max.
NO	0 ... 50 ppm	0 ... 5000 ppm
SO ₂	0 ... 50 ppm	0 ... 5000 ppm
CO ₂	0 ... 50 ppm	0 ... 25 vol%
CO	0 ... 50 ppm	0 ... 5000 ppm
O ₂	0 ... 5 vol%	0 ... 100 vol%

The O₂ ranges above are for the built-in magnetic analyzer.

System configuration example

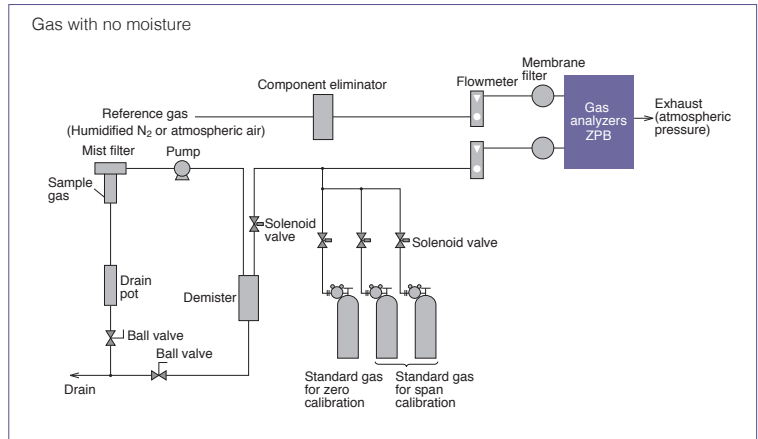

Single beam

Sample switching

2 components max.

NO

SO₂

CO₂

CO

O₂

Low-concentration measurement ZPG



	Min.	Max.
NO	0 ... 10 ppm	0 ... 100 ppm
SO ₂	0 ... 10 ppm	0 ... 100 ppm
CO ₂	0 ... 5 ppm	0 ... 50 ppm
CO	0 ... 5 ppm	0 ... 50 ppm
O ₂	0 ... 5 vol%	0 ... 100 vol%

The O₂ ranges above are for the built-in magnetic analyzer.

System configuration example

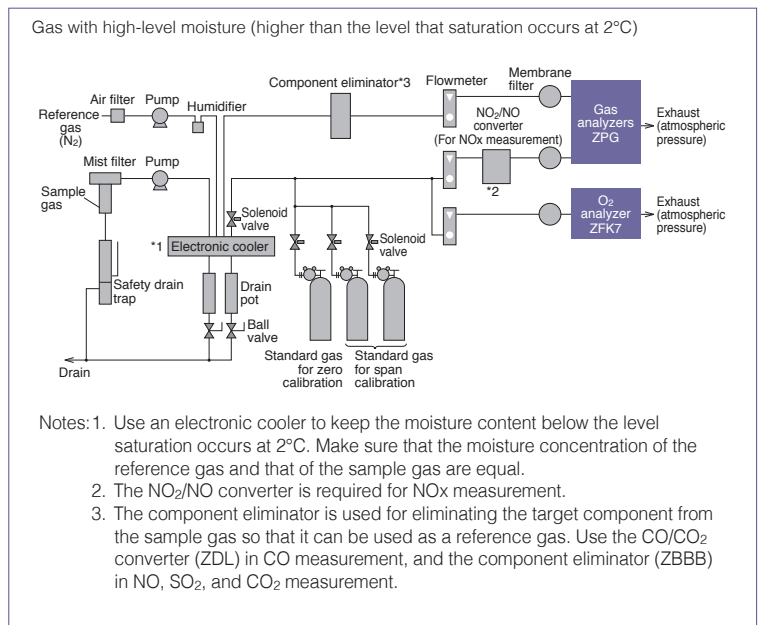

Specifications

	Standard version		Drift-less type		Low-concentration measurement type	
Model	ZPA		ZPB		ZPG	
Principle	NDIR (single beam) O ₂ : magnetic, galvanic, or external zirconia analyzer					
No. of components	≤ 5 (including O ₂)				≤ 2 (including O ₂)	
Components and ranges	Min	Max	Min	Max	Min	Max
NO	0 ... 200 ppm	0 ... 5000 ppm	0 ... 50 ppm	0 ... 5000 ppm	0 ... 10 ppm	0 ... 100 ppm
SO ₂	0 ... 200 ppm	0 ... 10 vol%	0 ... 50 ppm	0 ... 5000 ppm	0 ... 10 ppm	0 ... 100 ppm
CO ₂	0 ... 100 ppm	0 ... 100 vol%	0 ... 50 ppm	0 ... 25 vol%	0 ... 5 ppm	0 ... 50 ppm
CO	0 ... 200 ppm	0 ... 100 vol%	0 ... 50 ppm	0 ... 5000 ppm	0 ... 5 ppm	0 ... 50 ppm
CH ₄	0 ... 500 ppm	0 ... 100 vol%	–	–	–	–
O ₂ (built-in galvanic analyzer)	0 ... 10 vol%	0 ... 25 vol%	0 ... 10 vol%	0 ... 25 vol%	0 ... 10 vol%	0 ... 25 vol%
O ₂ (built-in magnetic analyzer)	0 ... 5 vol%	0 ... 100 vol%	0 ... 5 vol%	0 ... 100 vol%	0 ... 5 vol%	0 ... 100 vol%
O ₂ (external zirconia analyzer)	None	100 ... 95 vol%	–	–	–	–
O ₂ (external zirconia analyzer)	0 ... 5 vol%	0 ... 25 vol%	0 ... 5 vol%	0 ... 25 vol%	0 ... 5 vol%	0 ... 25 vol%
No. of ranges	Up to 2 ranges per component					
Repeatability	±0.5% FS					
Linearity	±1% FS					
Zero drift	±2% FS per week		±0.5% FS per week			
Span drift	±2% FS per week		±2% FS per week			
Response time (for 90%)	10 s ... 30 s (may vary with measurement range)		≤ 30 s Dead time varies within 5–20 seconds according to the setting for the sample switching.			
Output signal	4–20 mA DC or 0–1 V DC (ZPA and ZPB: ≤ 12 points, ZPG: ≤ 4 points)					
Display	LED-backlit LCD, instantaneous value, O ₂ corrected instantaneous value, O ₂ corrected average value, O ₂ average					
Range switching	by key operation, automatic, or remotely (option)					
Contact input (option)	Voltage input: remote range-switching, auto-calibration remote start, remote hold, average reset					
Contact output (option)	SPDT relay contact: analyzer error, calibration error, range identification, during auto-calibration, solenoid valve operation for auto-calibration, H/L limit alarm, CO peak alarm					
Atmospheric pressure correction (option)	Built-in option available					
Standard functions	Output hold, auto/manual range switching					
Optional functions	Auto calibration, auto calibration remote start, remote hold of output, range identification contact output, H/L limit alarm, O ₂ correction, O ₂ -corrected average values, average resetting contact input, CO peak alarm contact output					
Communication (option)	RS-485 (Modbus)					
Sample gas flow checker	None		Provided			
Gas inlet/outlet	Rc¼ or NPT¼ internal thread					
Purge gas flow rate	1 L/min (as needed)					
Reference gas	Not required		Required (dry N ₂ or dry air)			
Operating environment	-20°C ... +60°C, RH 90% or lower (no condensation)					
Mounting	19-inch rack mounting					
Power supply voltage	100–240 V AC, 50/60 Hz					
Power consumption	Approx. 100 VA		Approx. 120 VA		Approx. 100 VA	
Dimensions	483 (W) × 133 (H) × 382 (D) mm					
Weight	Approx. 11 kg		Approx. 13 kg		Approx. 11 kg	

Dimensions

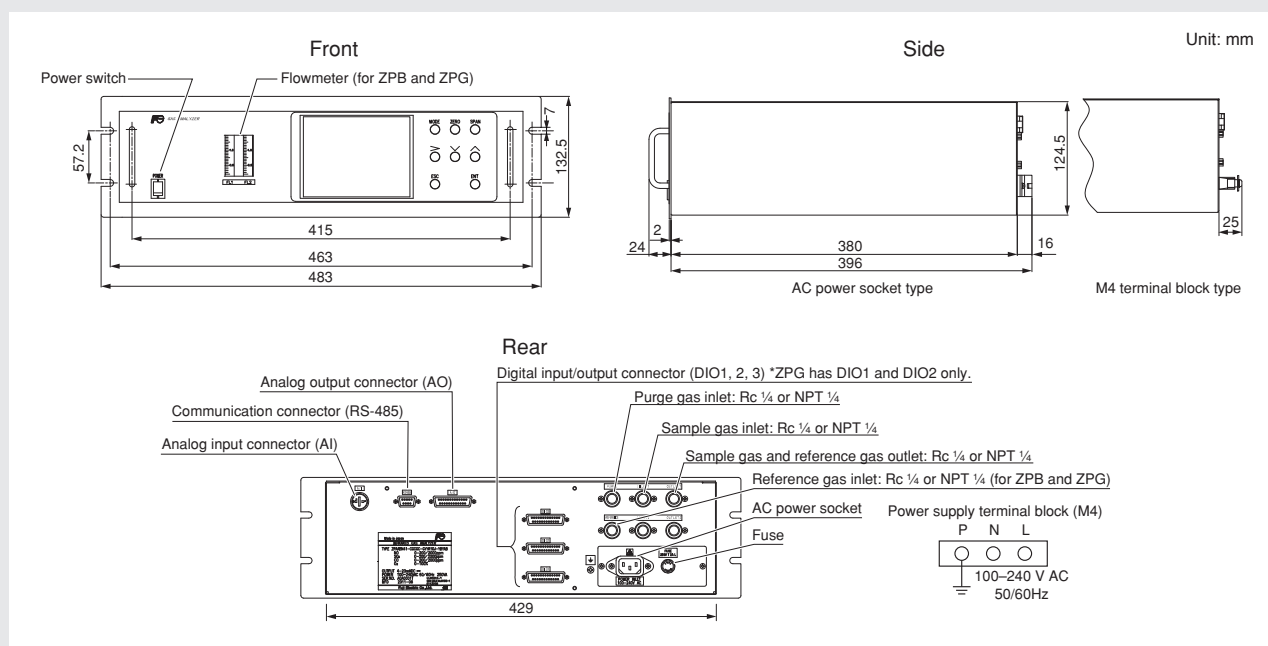

Double-beam

High-performance model ZKJ

5 components max.

NO

SO₂

CO₂

CO

CH₄

N₂O

O₂

- Zero point drift: ±1.0% FS per week
- Maximum range ratio of 1 : 25
- N₂O measurement available
- Hardly affected by interference from other gases
- Calibration, alarm, calculation
- Easy-to-see LCD

	Min.	Max
NO	0 ... 50 ppm	0 ... 5000 ppm
SO ₂	0 ... 50 ppm	0 ... 10 vol%
CO ₂	0 ... 20 ppm	0 ... 100 vol%
CO	0 ... 50 ppm	0 ... 100 vol%
CH ₄	0 ... 200 ppm	0 ... 100 vol%
N ₂ O	0 ... 200 ppm	0 ... 2000 ppm
O ₂	0 ... 5 vol%	0 ... 25 vol%



Specifications

Principle	NO, SO ₂ , CO ₂ , CO, CH ₄ , N ₂ O: double-beam NDIR O ₂ : built-in paramagnetic sensor or external zirconia analyzer
Repeatability	±0.5% FS (±1% FS for the ranges below 50 ppm)
Linearity	±1% FS
Zero drift	±1% FS per week (±2% FS per week for 50–200 ppm range)
Span drift	±2% FS per week (±2% FS per day for the ranges below 50 ppm)
Response time (for 90%)	≤ 60 s
Output signal	4–20 mA DC or 0–1 V DC, up to 12 points
External contact input	Dry contact Remote range-switching, auto-calibration remote start, remote hold, average value reset, pump ON/OFF
Contact output	SPST-NO and SPDT relay contacts Analyzer error, calibration error, range identification, under auto-calibration, pump ON/OFF, limit alarm CO peak alarm, H/L limit alarm, power interruption
Communication (separate order item)	RS-232C (Modbus)
Display	LED backlit LCD Instantaneous value, O ₂ -corrected instantaneous value, O ₂ corrected average value, O ₂ average
Power supply voltage	100–240 V AC, 50/60 Hz
Power consumption	250 VA
Dimensions	483 (W) × 177 (H) × 600 (D) mm
Weight	Approx. 22 kg

Double-Beam NDIR Sensor

Principle The mass flow sensor measures the amount of infrared absorbed in the measurement cell.

Double beam method achieves the range ratio of 1 : 25

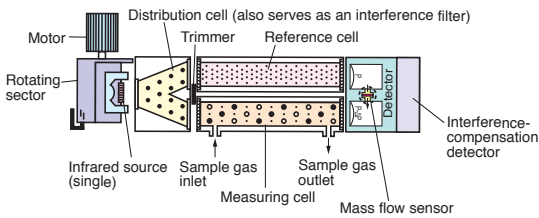

Mass flow sensor

Converts the amount of infrared absorption into electrical signals. Excellent noise resistance thanks to the low impedance sensor. The absence of moving parts makes the device resistant to vibration and semi-permanently usable.

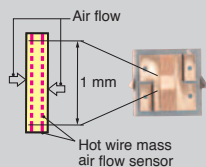

Information in this catalog is subject to change without notice.
Read the instruction manuals thoroughly before using the products.

F Fuji Electric Co., Ltd.

www.fujielectric.com

Instrumentation & Sensors Planning Dept.

Gate City Ohsaki, East Tower, 11-2, Osaki 1-chome, Shinagawa-ku, Tokyo 141-0032, Japan

Phone: +81-3-5435-7021 Fax: +81-3-5435-7475

www.fujielectric.com/products/instruments/