

# NDIR GAS ANALYZER (HIGH PERFORMANCE MODEL)

DATA SHEET

ZPB

This gas analyzer (ZPB) is capable of measuring the concentration of NO, SO<sub>2</sub>, CO<sub>2</sub>, CO and O<sub>2</sub> components in sample gas. NO, SO<sub>2</sub>, CO<sub>2</sub>, CO are measured by non-dispersion infrared method (NDIR), while O<sub>2</sub> is measured by fuel cell or paramagnetic and zirconia method. Through use of the sample switching system, ZPB is capable of canceling drift in the zero point of the measurable component by NDIR. Optimum use as an analyzer unit of a measurement system for combustion exhaust gas from refuse incinerators and boilers, or gas from various industrial furnaces.



## FEATURES

- High sensitivity**  
Equipped with the newest upgraded mass flow sensor. Capable of 0-50ppm measuring range with a newly designed measurement unit.
- Excellent stability**  
Due to adoption of sample switching method (note1). It is capable of canceling drift in the zero point of measurable component.
- Easy maintenance**  
Single beam design simplifies maintenance and minimizes maintenance costs compared with double beam or similarly equipped GFC based system.
- Small and light**  
The size is small 133x483x382mm (HxWxD) and light (13kg). The unit is capable of measuring up to 5 gas components in one analyzer.
- Extensive functions**  
Various optional functions are available such as auto calibration control, atmospheric pressure correction, high and low concentration alarms, remote range switch, and range identification signal, etc.  
note1) Excellent long term stability due to sample gas and reference gas flowed alternately to the measurement unit.

## SPECIFICATIONS

### Standard Specifications

Principle of measurement:  
 NO, SO<sub>2</sub>, CO<sub>2</sub>, CO;  
 Non-dispersion infrared-ray absorption method (NDIR method)  
 Single light source and single beams (single beam system)

O<sub>2</sub> ; Fuel cell O<sub>2</sub> analyzer (built in) or paramagnetic O<sub>2</sub> analyzer (built-in) or zirconia O<sub>2</sub> analyzer (externally installed TYPE: ZFK7)

Measurable gas components and measuring range:

	Minimum range	Maximum range
NO	0 - 50ppm	0 - 5000ppm
SO <sub>2</sub>	0 - 50ppm	0 - 5000ppm
CO <sub>2</sub>	0 - 50ppm	0 - 25vol%
CO	0 - 50ppm	0 - 5000ppm
O <sub>2</sub> (built in fuel cell)	0 - 10vol%	0 - 25vol%
O <sub>2</sub> (built-in Paramagnetic)	0 - 5vol%	0 - 100vol%
O <sub>2</sub> (External Zirconia)	0 - 5vol%	0 - 25vol%

- Max. 5 components measurement including O<sub>2</sub>.
- Measuring range ratio max. 1:10 (except O<sub>2</sub>)
- Measuring ranges are changeable between the specified minimum and maximum range  
Settable one range or two ranges  
\* In measurement range, low range is called first range, high range is called second range.
- For possible combinations of components and ranges, refer to Table 1.

Measured value indication:

- Digital indication in 4 digits (LCD panel with LED back light)
- Instantaneous value of each component
- Instantaneous value after O<sub>2</sub> correction (only in NO, SO<sub>2</sub>, CO measurement with O<sub>2</sub>)
- Average value after O<sub>2</sub> correction (only in NO, SO<sub>2</sub>, CO measurement with O<sub>2</sub>)
- O<sub>2</sub> average value

## Analog output signals:

4 to 20mA DC or 0 to 1V DC,  
isolated internally from circuit and ground.  
Output lines are non-isolated each other.;  
12 outputs max.

Allowable load 550Ω for 4 to 20mA DC

Allowable load 100kΩ for 0 to 1V DC

\* Refer to Table2 for the channel No. of  
displayed values and analog output  
signals.

## Analog input signal:

For signal input from externally installed  
O<sub>2</sub> analyzer.

Signal requirement;

(1) Signal from Fuji's Zirconia O<sub>2</sub> ana-  
lyzer (TYPE: ZFK7)

(2) 0 to 1V DC from an O<sub>2</sub> analyzer

Input section is not isolated. This fea-  
ture is effective when an O<sub>2</sub> analyzer  
is not built in.

\* Externally installed O<sub>2</sub> analyzer should  
be purchased separately.

## Digital output: (Option)

1c contact (24V DC/1A, resistive load)  
max.15 outputs

Instrument error, calibration error,  
range identification, auto calibration  
status, solenoid valve drive for auto  
calibration, High/Low limit alarm con-  
tact output

\* All relay contacts are isolated mutually  
and from the internal circuit.

## Digital input: (Option)

Voltage contact (supply 12 to 24V DC  
(15mA max)) Max.9 inputs

Remote range change over, auto cali-  
bration remote start, remote hold, av-  
erage value reset, Isolated from the  
internal circuit with photocoupler.

## Power supply:

Voltage rating ; 100V to 240V AC

Allowable range ; 85V to 264V AC

Frequency ; 50Hz/60Hz

Power consumption ; 110VA max.

## Operation conditions:

Ambient temperature ;

-5°C to 45°C

(40°C max. when 2 optical sys-  
temat 200V AC power source)

Ambient humidity ; 90% RH max.,  
non-condensing

## Storage conditions:

Ambient temperature ; -20°C to 60°C

Ambient humidity ; 100% RH max.,  
non-condensing

## Dimensions (H × W × D):

133 x 483 x 382mm

Mass: 13 kg max.

Finish color: Front panel; Cool gray (PANTON 1C-F)

Enclosure: Steel casing, for indoor use

## Material of gas-contacting parts:

Gas inlet/outlet; SUS304

Sample cell; SUS304, chloroprene rubber

Infrared-ray transmitting window; CaF<sub>2</sub>

Paramagnetic O<sub>2</sub> analyzer cell; SUS316

Fuel cell O<sub>2</sub> analyzer cell; ABS resin

Internal piping; Toaron, Teflon, Polypropylene

Solenoid valve; fluoro-rubber

Gas inlet/outlet: Rc1/4 or NPT1/4 internal thread

Purge gas flow rate: 1L/min (when required)

Life time of fuel cell O<sub>2</sub> analyzer: 2 years

## Standard Functions

## Output signal holding:

Output signals are held unchanged during  
manual and auto calibrations by activation  
of holding (turning "ON" its setting).

The values held are those just before start  
calibration mode or setting value.

Usage is selectable.

Indication of instantaneous values will not  
be held.

## Switch ranges:

The switch ranges function is available in  
manual, auto, and remote modes. Only  
preset switch method is effective.

Manual: Allows range to switch by key operation.

Auto: Automatically switched from first range to  
second range when the measured value  
exceeds 90%FS of first range.

Automatically switched from second range  
to first range when the measured value  
drops to 80% or less first range.

Remote: Voltage contact input

(Option) Allows range to switch via an external  
signal when remote range switch input is  
received.

When the contact input terminals for  
each component are input voltage, the  
first range is selected, and it is switched  
to the second range when the terminals  
are open.

\* These switch range value are settable between  
the first range and second range values (low/high  
range values).

## Optional Functions

## Remote output holding:

Output signal is held at the last value or  
preset value by voltage input to the remote  
output holding input terminals.

Holding is maintained while is voltage  
input to the terminals. Indication of in-  
stantaneous values are not held.

## Range identification signal:

The present measuring range is identified  
by a contact position.

The contact output terminals close for  
each component when the first range is  
selected, and open when the second range  
is selected.

## Auto calibration:

Auto calibration is carried out periodically  
at the preset cycle.

When a standard gas cylinder for calibra-  
tion and a solenoid valve for opening/  
closing the gas flow line are prepared  
externally by the customer, calibration  
will be carried out with the solenoid valve  
drive contacts for zero calibration and each  
span calibration turned on/off sequentially  
at the set auto calibration timing.

Auto calibration cycle setting:  
 Auto calibration cycle is set.  
 Setting is variable within 1 to 99 hours (in increments of 1 hour) or 1 to 40 days (in increments of 1 day).

Gas flow time setting:  
 The time for flowing each calibration gas in auto calibration is set.  
 Settable within 60 to 900 seconds (in increments of 1 second)

Auto calibration remote start:  
 Auto calibration starts by opening the auto calibration remote start input terminal after short circuiting for 1.5 sec or longer.  
 Auto calibration starts when contacts open.

Auto zero calibration:  
 Auto zero calibration is carried out periodically at the preset cycle.  
 This cycle is independent from "Auto calibration" cycle.  
 When zero calibration gas and solenoid valve for opening/closing the calibration gas flow line are prepared externally by the customer, zero calibration will be carried out at the set auto zero calibration timing.

Auto zero calibration cycle setting:  
 Auto zero calibration cycle is set.  
 Setting is variable within 1 to 99 hours (in increments of 1 hour) or 1 to 40 days (in increments of 1 day)

Gas flow time setting:  
 The timing for flowing zero gas in auto zero calibration is set.  
 Settable within 60 to 900 seconds (in increments of 1 second)

High/low limit alarm:  
 Alarm contact output turns on when measurement value reaches the preset high or low limit alarm value.  
 Contacts close when the instantaneous value of each channel exceeds the high alarm limit value or falls below the low alarm limit value.

Instrument error contact output:  
 Contacts turn on at occurrence of analyzer error No. 1, 2, 3 or 10.

Calibration error contact output:  
 Contacts turn on at occurrence of manual or auto calibration error (any of errors No. 4 to 9).

Auto calibration status contact outputs:  
 Contacts turn on during auto calibration.

O<sub>2</sub> correction: Correction of measured NO, SO<sub>2</sub> and CO gas concentrations into values at reference O<sub>2</sub> concentration.

Correction formula:

$$C = \frac{21-O_n}{21-O_s} \times C_s$$

C : Sample gas concentration after O<sub>2</sub> correction

C<sub>s</sub> : Measured concentration of sample gas

O<sub>s</sub> : Measured O<sub>2</sub> concentration (Limit setting: 1 to 20% O<sub>2</sub>)

O<sub>n</sub> : Reference O<sub>2</sub> concentration (value changeable by setting.0 to 19% O<sub>2</sub>)

Average value after O<sub>2</sub> correction and O<sub>2</sub> average value calculation:

The result of O<sub>2</sub> correction or instantaneous O<sub>2</sub> value can be output as an average value over the preset period of time.

Moving average method is used. Sampling interval is 30 secs.

(Output is updated every 30 seconds.

Update is the averaged value of the most recently elapsed averaging time period.)

Averaging time period is settable within 1 to 59 minutes (in increments of 1 minute) or 1 to 4 hours (in increments of 1 hour).

Average value resetting:

The above-mentioned output of average value is started from the initial state by opening the average value resetting input terminals after short circuiting for 1.5 sec or longer.

Output is reset by input voltage and restarted by opening the terminal circuit.

Communication function:

RS-485 (9pins D-sub connector)

Half-duplex bit serial

Start-stop synchronization

Modbus RTU™ protocol

Contents : Read/Write parameters

Read measurement concentration and instrument status.

Remark : When connecting via RS-232C interface, an RS-232C ↔ RS-485 converter should be used.

Atmospheric pressure correction:

Measure atmospheric pressure and calculate compensation (for use, be sure to relieve the exhaust gas from analyzer to the atmosphere)

After atmospheric pressure correction;

Zero point : No influenced

Span point: The change is 0.5% measured value or less relating to the change of the atmospheric pressure 1%.

Correction range: 700hPa-1050hPa

**Performance**

Repeatability:	±0.5% of full scale
Linearity:	±1% of full scale prior to atmospheric pressure correction (option)
Zero drift:	±0.5% of full scale/week (measurable component of NDIR) ±2.0% of full scale/week (O <sub>2</sub> analyzer)
Span drift:	±2.0% of full scale/week
Response time (T <sub>90</sub> ):	30 seconds or better Response interval may be changed depending on timing of the switching gas by sample switching operation. (T <sub>d</sub> =5-20 seconds)
Interference from other gases:	Sample switching design effectively minimizes interference. But it may occur depending on component gas and its concentration. Preprocessing can further decrease influence in this case. Contact manufacturer for application specific advice.

**Requirements for Sample Gas**

Flow rate:	1.0 ±0.2L / min
Temperature:	0 to 50°C
Pressure:	10 kPa or less (Gas outlet side should be open to the atmospheric air.)
Dust:	100 µg/Nm <sup>3</sup> or less in particle size of 0.3 µm or smaller
Mist:	Unallowable
Moisture:	Less than 2°C saturation point. (Contain comparable sample gas and reference gas)
Corrosive component:	1 ppm or less
Standard gas for calibration:	1) For measurement with IR and/or built-in O <sub>2</sub> sensor Zero gas ; Dry N <sub>2</sub> Span gas ; Each sample gas having concentration 90 to 100% of its measuring range (recommended). 2) In case a zirconia O <sub>2</sub> analyzer is installed externally and calibration is carried out on the same calibration gas line: Zero gas ; Dry air or atmospheric air (Do not use with CO <sub>2</sub> measurement) Span gas ; For other than O <sub>2</sub> measurement, each sample gas having concentration 90 to 100% of its measuring range For O <sub>2</sub> measurement, O <sub>2</sub> gas of 1 to 2 vol%/remains N <sub>2</sub> gas

## Reference gas for sample switching:

For sample gas dewpoint > 2°C sample switching reference gas is wet N<sub>2</sub> or atmospheric air.

For sample gas dewpoint < 2°C use dry N<sub>2</sub> or dry air. (Do not contain the component to be measured more than 0.1%FS of the minimum measuring range.)

Please refer to the "component eliminator" as described later and use the component eliminator to meet the above condition if necessary.

If CO<sub>2</sub> meter is used, do not use the atmosphere/Dry air.)

## Purge gas:

When base gas is H<sub>2</sub> and CO<sub>2</sub> meter is under this condition that measuring range is 100ppm or less,  
Please purge the inside of the instrument.

**Installation Requirements**

- Indoor use (Select a place where the equipment does not receive direct sunlight, draft/rain or radiation from hot substances. If such a place cannot be found, a roof or cover should be prepared for protection.)
- Avoid a place where unit receives heavy vibration.
- Select a place where atmospheric air is clean.

**EU Directive Compliance** 

LVD (2014/35/EU)

EN 61010-1

EN 62311

EMC (2014/30/EU)

EN 61326-1 (Table 2)

EN 61000-3-2 (Class A)

EN 61000-3-3

EN 61326-2-3

RoHS (2011/65/EU+(EU)2015/863)

EN IEC63000

## Principle diagram of NDIR type measurement (For NO, SO<sub>2</sub>, CO<sub>2</sub>, CO)

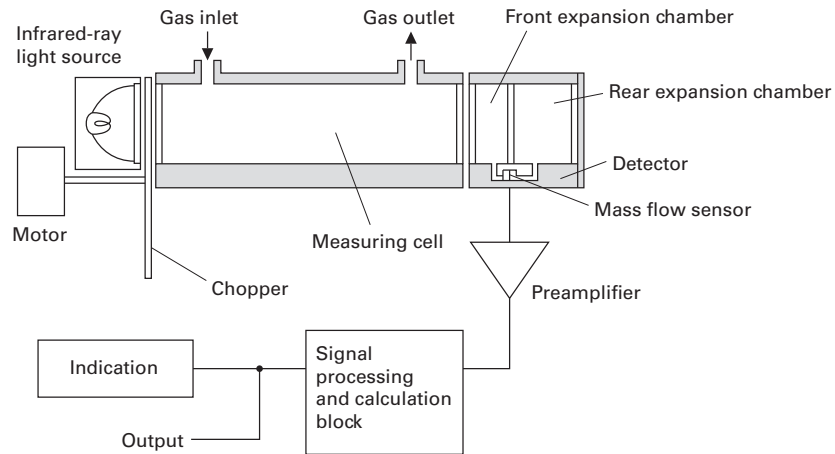

## Principle diagram of fuel cell type measurement (For O<sub>2</sub>)

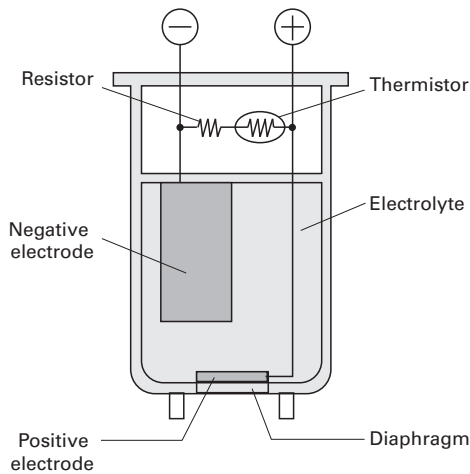

## Principle diagram of paramagnetic type measurement (For O<sub>2</sub>)

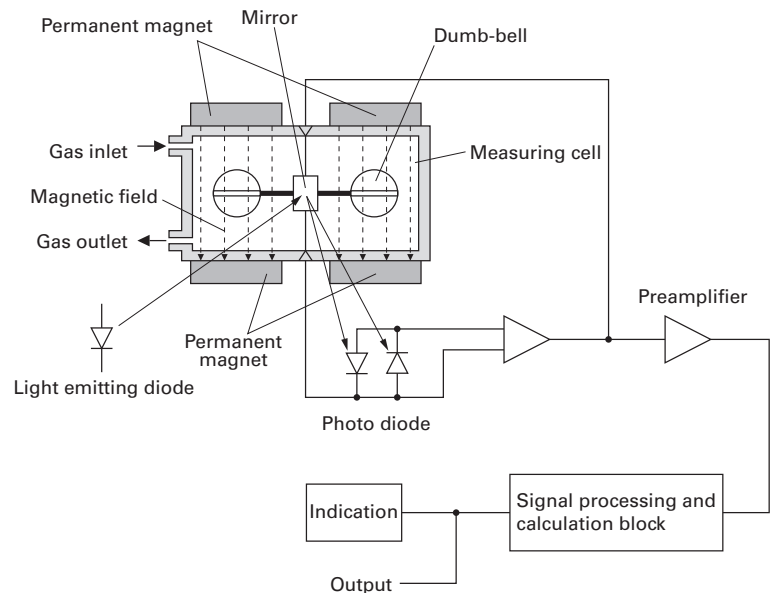

## Principle diagram of Sample switching method

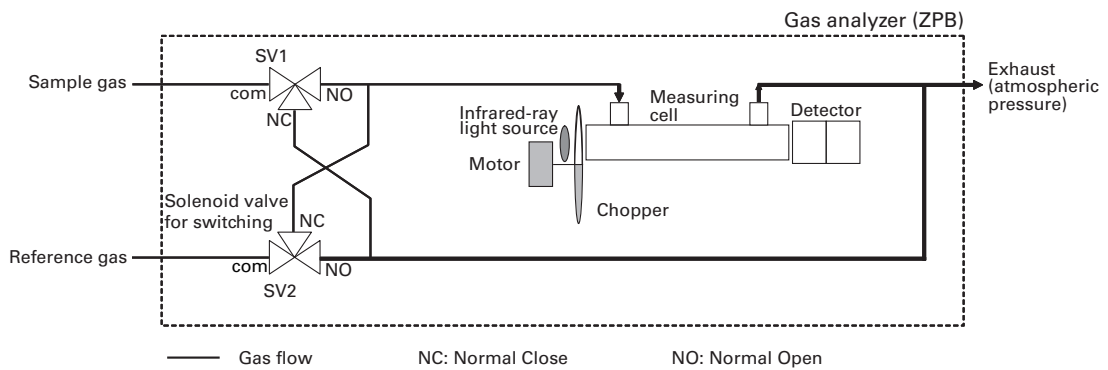

### Explanation of the sample switching method

Sample gas and reference gas are introduced alternately and constantly to the sample cell of the analyzer by Solenoid valve for switching flow (SV1,SV2)

Solenoid valve SV1 and Solenoid valve SV2 are switched by the signal sent from the analyzer.

Analyzer measures each sample gas and each reference gas on proper timing and calculates the change of the sample gas and reference gas as the concentrate value (= gas concentration of the measurable component) and sends output signal.

Due to monitoring the change of the sample gas and reference gas all the time, influence of the interference components and zero drift are eliminated.

## Examples of sampling system configuration including gas analyzer

\* These are a typical configuration. As configuration might be different depending on measuring objects. Please consult with us.

### 1) To measure sample gas without moisture.

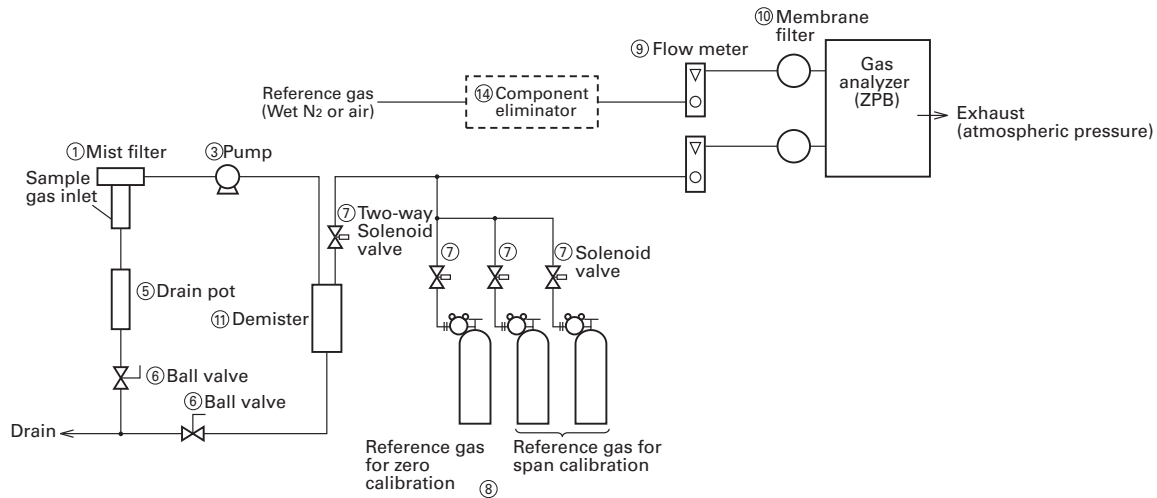

### 2) To measure high moisture content sample gas, NO, SO<sub>2</sub>, or CO (saturation 2°C or more)

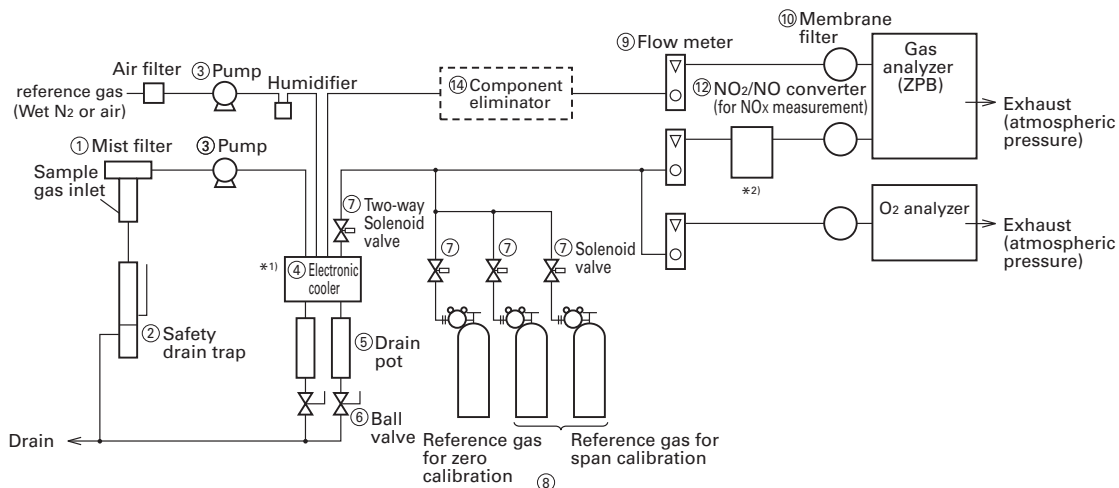

\*1) Be sure to remove the moisture to be temperature 5°C or lower from measuring gas by electronic cooler and water concentration should be equalized in sample gas and reference gas.

\*2) Be sure to use NO<sub>2</sub>/NO converter in case of measuring NO<sub>x</sub>.

## List of sampling devices (example)

No.	Device name	Fuji's type	No.	Device name	Fuji's type
①	Mist filter	ZBBK1V03-0	⑨	Flow meter	ZBD42203
②	Safety drain trap	ZBH51603	⑩	Membrane filter	ZBBM2V03-0
③	Pump	ZBG80	⑪	Demister	ZBH35003
④	Electronic cooler	ZBC9A004	⑫	NO <sub>2</sub> /NO converter	ZDL04001
⑤	Drain pot	ZBH13003 (Length 255mm)	⑬	Three-way solenoid valve	
⑥	Ball valve	ZBFB1	⑭	Component eliminator (for NO <sub>x</sub> and SO <sub>2</sub> )	ZBBB6V03 or 7V03 *3
⑦	Two-way solenoid valve			Component eliminator (for NO <sub>x</sub> and SO <sub>2</sub> )	ZBBB7V03 or 6V03 *3
⑧	Standard gas for calibration	ZBM□Y04-0□ (Codes in □ to be selected depending on application)		Component eliminator (for CO <sub>2</sub> )	ZBBB8V03
				Component eliminator (for CO)	ZDL21001

\*3) Refer to SANPLING DEVICE SERIES DATA SHEET(EDS3-1), chapter GAS FILTER(model:ZBB)

**Table 1 Measurable component and range - availability check table -**

Procedure of range selection

On one component analyzer:

First determine 1st range, then select 2nd range from the corresponding right column.

More than two components:

The 2nd range in the tables for two and more components is maximum available range.

Select the 2nd range less than or equal to the "2nd range (max)".

1-component analyzer:NO

1st range	2nd range					
0-50ppm	None	0-100ppm	0-200ppm	0-250ppm	0-300ppm	0-500ppm
0-100ppm	None	0-200ppm	0-250ppm	0-300ppm	0-500ppm	0-1000ppm
0-200ppm	None	0-250ppm	0-300ppm	0-500ppm	0-1000ppm	0-2000ppm
0-250ppm	None	0-300ppm	0-500ppm	0-1000ppm	0-2000ppm	
0-300ppm	None	0-500ppm	0-1000ppm	0-2000ppm		
0-500ppm	None	0-1000ppm	0-2000ppm	0-2500ppm	0-3000ppm	0-5000ppm
0-1000ppm	None	0-2000ppm	0-2500ppm	0-3000ppm	0-5000ppm	
0-2000ppm	None	0-2500ppm	0-3000ppm	0-5000ppm		
0-2500ppm	None	0-3000ppm	0-5000ppm			
0-3000ppm	None	0-5000ppm				
0-5000ppm	None					

1-component analyzer:SO<sub>2</sub>

1st range	2nd range					
0-50ppm	None	0-100ppm	0-200ppm	0-250ppm	0-300ppm	0-500ppm
0-100ppm	None	0-200ppm	0-250ppm	0-300ppm	0-500ppm	0-1000ppm
0-200ppm	None	0-250ppm	0-300ppm	0-500ppm	0-1000ppm	0-2000ppm
0-250ppm	None	0-300ppm	0-500ppm	0-1000ppm	0-2000ppm	0-2500ppm
0-300ppm	None	0-500ppm	0-1000ppm	0-2000ppm	0-2500ppm	0-3000ppm
0-500ppm	None	0-1000ppm	0-2000ppm	0-2500ppm	0-3000ppm	0-5000ppm
0-1000ppm	None	0-2000ppm	0-2500ppm	0-3000ppm	0-5000ppm	0-1%
0-2000ppm	None	0-2500ppm	0-3000ppm	0-5000ppm		
0-2500ppm	None	0-3000ppm	0-5000ppm			
0-3000ppm	None	0-5000ppm				
0-5000ppm	None					

1-component analyzer:CO

1st range	2nd range					
0-50ppm	None	0-100ppm	0-200ppm	0-250ppm	0-300ppm	0-500ppm
0-100ppm	None	0-200ppm	0-250ppm	0-300ppm	0-500ppm	0-1000ppm
0-200ppm	None	0-250ppm	0-300ppm	0-500ppm	0-1000ppm	0-2000ppm
0-250ppm	None	0-300ppm	0-500ppm	0-1000ppm	0-2000ppm	0-2500ppm
0-300ppm	None	0-500ppm	0-1000ppm	0-2000ppm	0-2500ppm	0-3000ppm
0-500ppm	None	0-1000ppm	0-2000ppm	0-2500ppm	0-3000ppm	0-5000ppm
0-1000ppm	None	0-2000ppm	0-2500ppm	0-3000ppm	0-5000ppm	0-1%
0-2000ppm	None	0-2500ppm	0-3000ppm	0-5000ppm		
0-2500ppm	None	0-3000ppm	0-5000ppm			
0-3000ppm	None	0-5000ppm				
0-5000ppm	None					

1-component analyzer:CO<sub>2</sub>

1st range	2nd range					
0-50ppm	None	0-100ppm	0-200ppm	0-250ppm	0-300ppm	0-500ppm
0-100ppm	None	0-200ppm	0-250ppm	0-300ppm	0-500ppm	0-1000ppm
0-200ppm	None	0-250ppm	0-300ppm	0-500ppm	0-1000ppm	0-2000ppm
0-250ppm	None	0-300ppm	0-500ppm	0-1000ppm	0-2000ppm	0-2500ppm
0-300ppm	None	0-500ppm	0-1000ppm	0-2000ppm	0-2500ppm	0-3000ppm
0-500ppm	None	0-1000ppm	0-2000ppm	0-2500ppm	0-3000ppm	0-5000ppm
0-1000ppm	None	0-2000ppm	0-2500ppm	0-3000ppm	0-5000ppm	0-1%
0-2000ppm	None	0-2500ppm	0-3000ppm	0-5000ppm		
0-2500ppm	None	0-3000ppm	0-5000ppm			
0-3000ppm	None	0-5000ppm				
0-5000ppm	None					

2-component analyzer:NO/SO<sub>2</sub>

1-component:NO	
1st range	2nd range (max)
0-50ppm	0-500ppm
0-100ppm	0-1000ppm
0-200ppm	0-2000ppm
0-250ppm	0-2500ppm
0-300ppm	0-2500ppm
0-500ppm	0-5000ppm
0-1000ppm	0-5000ppm
0-2000ppm	0-5000ppm
0-2500ppm	0-5000ppm
0-3000ppm	0-5000ppm
0-5000ppm	None

2-component:SO <sub>2</sub>	
1st range	2nd range (max)
0-50ppm	0-500ppm
0-100ppm	0-1000ppm
0-200ppm	0-2000ppm
0-250ppm	0-2500ppm
0-300ppm	0-2500ppm
0-500ppm	0-5000ppm
0-1000ppm	0-5000ppm
0-2000ppm	0-5000ppm
0-2500ppm	0-5000ppm
0-3000ppm	0-5000ppm
0-5000ppm	None

The second component should be selected as shown in the right table.

2-component analyzer:NO/CO

1-component:NO	
1st range	2nd range (max)
0-50ppm	0-500ppm
0-100ppm	0-1000ppm
0-200ppm	0-2000ppm
0-250ppm	0-2500ppm
0-300ppm	0-2500ppm
0-500ppm	0-5000ppm
0-1000ppm	0-5000ppm
0-2000ppm	0-5000ppm
0-2500ppm	0-5000ppm
0-3000ppm	0-5000ppm
0-5000ppm	None

2-component:CO	
1st range	2nd range (max)
0-50ppm	0-500ppm
0-100ppm	0-1000ppm
0-200ppm	0-2000ppm
0-250ppm	0-2500ppm
0-300ppm	0-2500ppm
0-500ppm	0-5000ppm
0-1000ppm	0-5000ppm
0-2000ppm	0-5000ppm
0-2500ppm	0-5000ppm
0-3000ppm	0-5000ppm
0-5000ppm	None

The second component should be selected as shown in the right table.

2-component analyzer:CO<sub>2</sub>/CO

1-component:CO <sub>2</sub>		2-component:CO	
1st range	2nd range (max)	1st range/2nd range (max)	
0-50ppm	0-500ppm	0-50/500ppm, 0-100/1000ppm, 0-200/2000ppm, 0-250/2000ppm, 0-300/2000ppm, 0-500/5000ppm, 0-1000/5000ppm, 0-2000/5000ppm, 0-2500/5000ppm, 0-3000/5000ppm, 0-5000ppm	
0-100ppm	0-1000ppm		
0-200ppm			
0-250ppm			
0-300ppm			
0-500ppm			
0-200ppm	0-2000ppm	0-500/5000ppm, 0-1000/5000ppm, 0-2000/5000ppm, 0-2500/5000ppm, 0-3000/5000ppm, 0-5000ppm	
0-250ppm	0-2500ppm		
0-300ppm			
0-500ppm			
0-1000ppm			
0-2000ppm			
0-2500ppm	0-5000ppm		
0-3000ppm			
0-3000ppm			
0-3000ppm			
0-5000ppm			
0-5%	0-25%	0-50/500ppm, 0-100/1000ppm, 0-200/2000ppm, 0-250/2000ppm, 0-300/2000ppm, 0-500/5000ppm, 0-1000/5000ppm, 0-2000/5000ppm, 0-2500/5000ppm, 0-3000/5000ppm, 0-5000ppm	
0-10%	0-25%		
0-20%	0-25%		
0-25%	0-25%		

3-component analyzer:NO/SO<sub>2</sub>/CO >>> Combination of 1st component NO and 2nd component SO<sub>2</sub>/3rd component CO

1-component:NO	
1st range	2nd range (max)
0-50ppm	0-500ppm
0-100ppm	0-1000ppm
0-200ppm	0-2000ppm
0-250ppm	0-2500ppm
0-300ppm	0-2500ppm
0-500ppm	0-5000ppm
0-1000ppm	0-5000ppm
0-2000ppm	0-5000ppm
0-2500ppm	0-5000ppm
0-3000ppm	0-5000ppm
0-5000ppm	None

+

2-component:SO <sub>2</sub>		3-component:CO
1st range	2nd range (max)	1st range/2nd range (max)
0-50ppm	0-500ppm	0-50/500ppm, 0-100/1000ppm, 0-200/2000ppm, 0-250/2000ppm, 0-300/2000ppm, 0-500/2000ppm, 0-1000/2000ppm, 0-2000ppm
0-100ppm	0-1000ppm	
0-200ppm	0-2000ppm	0-50/500ppm, 0-100/1000ppm, 0-200/2000ppm, 0-250/2500ppm, 0-300/2500ppm, 0-500/3000ppm, 0-1000/3000ppm, 0-2000/3000ppm, 0-2500/3000ppm, 0-3000ppm
0-250ppm	0-2500ppm	
0-300ppm		0-3000ppm
0-500ppm		
0-1000ppm		
0-2000ppm		
0-2500ppm	0-5000ppm	0-200/2000ppm, 0-250/2500ppm, 0-300/2500ppm, 0-500/5000ppm, 0-1000/5000ppm, 0-2000/5000ppm, 0-2500/5000ppm, 0-3000/5000ppm, 0-5000ppm
0-500ppm		
0-1000ppm		
0-2000ppm		
0-2500ppm	0-5000ppm	0-500/5000ppm, 0-1000/5000ppm, 0-2000/5000ppm, 0-2500/5000ppm, 0-3000/5000ppm, 0-5000ppm
0-3000ppm		
0-5000ppm	None	

4-component analyzer:NO/SO<sub>2</sub>/CO<sub>2</sub>/CO >>> 1st NO/4th CO and 2nd SO<sub>2</sub>/3rd CO<sub>2</sub>

1-component:NO	
1st range	2nd range (max)
0-50ppm	0-500ppm
0-100ppm	0-1000ppm
0-200ppm	0-2000ppm
0-250ppm	0-2500ppm
0-300ppm	0-2500ppm
0-500ppm	0-5000ppm
0-1000ppm	0-5000ppm
0-2000ppm	0-5000ppm
0-2500ppm	0-5000ppm
0-3000ppm	0-5000ppm
0-5000ppm	None

+

2-component:SO <sub>2</sub>		4-component:CO
1st range	2nd range (max)	1st range/2nd range (max)
0-50ppm	0-500ppm	0-50/500ppm, 0-100/1000ppm, 0-200/2000ppm, 0-250/2000ppm, 0-300/2000ppm, 0-500/2000ppm, 0-1000/2000ppm, 0-2000ppm
0-100ppm	0-1000ppm	
0-200ppm	0-2000ppm	0-50/500ppm, 0-100/1000ppm, 0-200/2000ppm, 0-250/2500ppm, 0-300/2500ppm, 0-500/3000ppm, 0-1000/3000ppm, 0-2000/3000ppm, 0-2500/3000ppm, 0-3000ppm
0-250ppm	0-2500ppm	
0-300ppm		
0-500ppm		
0-1000ppm		
0-2000ppm	0-3000ppm	0-50/500ppm, 0-100/1000ppm, 0-200/2000ppm, 0-250/2500ppm, 0-300/2500ppm, 0-500/5000ppm, 0-1000/5000ppm, 0-2000/5000ppm, 0-2500/5000ppm, 0-3000/5000ppm, 0-5000ppm
0-2500ppm		
0-500ppm	0-5000ppm	0-200/2000ppm, 0-250/2500ppm, 0-300/2500ppm, 0-500/5000ppm, 0-1000/5000ppm, 0-2000/5000ppm, 0-2500/5000ppm, 0-3000/5000ppm, 0-5000ppm
0-1000ppm		
0-2000ppm		
0-2500ppm		
0-3000ppm	0-5000ppm	0-500/5000ppm, 0-1000/5000ppm, 0-2000/5000ppm, 0-2500/5000ppm, 0-3000/5000ppm, 0-5000ppm
0-5000ppm	None	

+

CO<sub>2</sub> component analyzer

3-component:CO <sub>2</sub>	
1st range	2nd range (max)
0-5vol%	0-25vol%

**Table 2 Channel (Ch) No. and display/output contents comparison table**

Code symbol			Display /output contents
6th digit	7th digit	21st digit	
P	Y	Y	Ch1:NO
A	Y	Y	Ch1:SO <sub>2</sub>
D	Y	Y	Ch1:CO <sub>2</sub>
B	Y	Y	Ch1:CO
F	Y	Y	Ch1:NO, Ch2:SO <sub>2</sub>
G	Y	Y	Ch1:NO, Ch2:CO
J	Y	Y	Ch1:CO <sub>2</sub> , Ch2:CO
N	Y	Y	Ch1:NO, Ch2:SO <sub>2</sub> , Ch3:CO
V	Y	Y	Ch1:NO, Ch2:SO <sub>2</sub> , Ch3:CO <sub>2</sub> , Ch4:CO
P	1to 4	Y	Ch1:NO, Ch2:O <sub>2</sub>
A	1to 4	Y	Ch1:SO <sub>2</sub> , Ch2:O <sub>2</sub>
D	1to 4	Y	Ch1:CO <sub>2</sub> , Ch2:O <sub>2</sub>
B	1to 4	Y	Ch1:CO, Ch2:O <sub>2</sub>
F	1to 4	Y	Ch1:NO, Ch2:SO <sub>2</sub> , Ch3:O <sub>2</sub>
G	1to 4	Y	Ch1:NO, Ch2:CO, Ch3:O <sub>2</sub>
J	1to 4	Y	Ch1:CO <sub>2</sub> , Ch2:CO, Ch3:O <sub>2</sub>
N	1to 4	Y	Ch1:NO, Ch2:SO <sub>2</sub> , Ch3:CO, Ch4:O <sub>2</sub>
V	1to 4	Y	Ch1:NO, Ch2:SO <sub>2</sub> , Ch3:CO <sub>2</sub> , Ch4:CO, Ch5:O <sub>2</sub>
P	1to 4	A *	Ch1:NO <sub>x</sub> , Ch2:O <sub>2</sub> , Ch3:corrected NO <sub>x</sub>
A	1to 4	A *	Ch1:SO <sub>2</sub> , Ch2:O <sub>2</sub> , Ch3:corrected SO <sub>2</sub>
B	1to 4	A *	Ch1:CO, Ch2:O <sub>2</sub> , Ch3:corrected CO
F	1to 4	A *	Ch1:NO <sub>x</sub> , Ch2:SO <sub>2</sub> , Ch3:O <sub>2</sub> , Ch4:corrected NO <sub>x</sub> , Ch5:corrected SO <sub>2</sub>
G	1to 4	A *	Ch1:NO <sub>x</sub> , Ch2:CO, Ch3:O <sub>2</sub> , Ch4:corrected NO <sub>x</sub> , Ch5:corrected CO
J	1to 4	A *	Ch1:CO <sub>2</sub> , Ch2:CO, Ch3:O <sub>2</sub> , Ch4:corrected CO
N	1to 4	A *	Ch1:NO <sub>x</sub> , Ch2:SO <sub>2</sub> , Ch3:CO, Ch4:O <sub>2</sub> , Ch5:corrected NO <sub>x</sub> , Ch6:corrected SO <sub>2</sub> , Ch7:corrected CO
V	1to 4	A *	Ch1:NO <sub>x</sub> , Ch2:SO <sub>2</sub> , Ch3:CO <sub>2</sub> , Ch4:CO, Ch5:O <sub>2</sub> , Ch6:corrected NO <sub>x</sub> , Ch7:corrected SO <sub>2</sub> , Ch8:corrected CO
P	1to 4	C *	Ch1:NO <sub>x</sub> , Ch2:O <sub>2</sub> , Ch3:corrected NO <sub>x</sub> , Ch4:corrected NO <sub>x</sub> average
A	1to 4	C *	Ch1:SO <sub>2</sub> , Ch2:O <sub>2</sub> , Ch3:corrected SO <sub>2</sub> , Ch4:corrected SO <sub>2</sub> average
B	1to 4	C *	Ch1:CO, Ch2:O <sub>2</sub> , Ch3:corrected CO, Ch4:corrected CO average
F	1to 4	C *	Ch1:NO <sub>x</sub> , Ch2:SO <sub>2</sub> , Ch3:O <sub>2</sub> , Ch4:corrected NO <sub>x</sub> , Ch5:corrected SO <sub>2</sub> , Ch6:corrected NO <sub>x</sub> average, Ch7:corrected SO <sub>2</sub> average
G	1to 4	C *	Ch1:NO <sub>x</sub> , Ch2:CO, Ch3:O <sub>2</sub> , Ch4:corrected NO <sub>x</sub> , Ch5:corrected CO, Ch6:corrected NO <sub>x</sub> average, Ch7:corrected CO average
J	1to 4	C *	Ch1:CO <sub>2</sub> , Ch2:CO, Ch3:O <sub>2</sub> , Ch4:corrected CO, Ch5:corrected CO average
N	1to 4	C *	Ch1:NO <sub>x</sub> , Ch2:SO <sub>2</sub> , Ch3:CO, Ch4:O <sub>2</sub> , Ch5:corrected NO <sub>x</sub> , Ch6:corrected SO <sub>2</sub> , Ch7:corrected CO, Ch8:corrected NO <sub>x</sub> average, Ch9:corrected SO <sub>2</sub> average, Ch10:corrected CO average
V	1to 4	C *	Ch1:NO <sub>x</sub> , Ch2:SO <sub>2</sub> , Ch3:CO <sub>2</sub> , Ch4:CO, Ch5:O <sub>2</sub> , Ch6:corrected NO <sub>x</sub> , Ch7:corrected SO <sub>2</sub> , Ch8:corrected CO, Ch9:corrected NO <sub>x</sub> average, Ch10 :corrected SO <sub>2</sub> average, Ch11:corrected CO average

\* When the 21st digit code is A or C, the component of the NO analyzer is displayed as NO<sub>x</sub>.

CODE SYMBOLS

Digit	Description	note	1	2	3	4	5	6	7	8	9	10	11	12	13	14	15	16	17	18	19	20	21	22	23	24	25	← Digit
4	<Specification/structure> Horizontal type(Terminal block for power supply) Horizontal type(Power inlet,with lock)	note1	Z	P	B	B				2																		
5	<Mounting> 19 inch rack mounting type EIA conformity(horizontal type)							B																				
6	<Measurable component (NDIR)> 1st component   2nd component   3rd component   4th component																											
	NO	-																										
	SO <sub>2</sub>	-																										
	CO <sub>2</sub>	-																										
	CO	-																										
	NO	SO <sub>2</sub>																										
	NO	CO																										
	CO <sub>2</sub>	CO																										
	NO	SO <sub>2</sub>																										
	NO	SO <sub>2</sub>																										
	Others																											
7	<Measurable component (O <sub>2</sub> )> None External O <sub>2</sub> analyzer External zirconia O <sub>2</sub> analyzer (ZFK7) Built-in fuel cell O <sub>2</sub> analyzer Built-in paramagnetic O <sub>2</sub> analyzer	note2																										
	None																											
	External O <sub>2</sub> analyzer																											
	External zirconia O <sub>2</sub> analyzer (ZFK7)																											
	Built-in fuel cell O <sub>2</sub> analyzer																											
	Built-in paramagnetic O <sub>2</sub> analyzer																											
8	<Revision code>																											
9	<Measuring range (NDIR)>1st component, 1st range	note3																										
10	<Measuring range (NDIR)>1st component, 2nd range	note3																										
11	<Measuring range (NDIR)>2nd component, 1st range	note3																										
12	<Measuring range (NDIR)>2nd component, 2nd range	note3																										
13	<Measuring range (NDIR)>3rd component, 1st range	note3																										
14	<Measuring range (NDIR)>3rd component, 2nd range	note3																										
15	<Measuring range (NDIR)>4th component, 1st range	note3																										
16	<Measuring range (NDIR)>4th component, 2nd range	note3																										
17	<Measuring range (O <sub>2</sub> )> None 0-5/10vol% 0-5/25vol% 0-10/25vol% 0-5vol% 0-10vol% 0-25vol% 0-50vol% 0-100vol% Others																											
	None																											
	0-5/10vol%																											
	0-5/25vol%																											
	0-10/25vol%																											
	0-5vol%																											
	0-10vol%																											
	0-25vol%																											
	0-50vol%																											
	0-100vol%																											
	Others																											
18	<Gas connection> Rc1/4 NPT1/4																											
	Rc1/4																											
	NPT1/4																											
19	<Output> DC0-1V DC4-20mA DC0-1V + Communication function DC4-20mA + Communication function																											
	DC0-1V																											
	DC4-20mA																											
	DC0-1V + Communication function																											
	DC4-20mA + Communication function																											
20	<Language/power supply cord> In Japanese, cord rated 125V (PSE) In English, cord rated 125V (UL) In English, cord rated 250V (CEE) In Chinese, cord rated 250V (CCC)	note4 note4 note4 note4																										
	In Japanese, cord rated 125V (PSE)	note4																										
	In English, cord rated 125V (UL)	note4																										
	In English, cord rated 250V (CEE)	note4																										
	In Chinese, cord rated 250V (CCC)	note4																										
21	<O <sub>2</sub> correction and O <sub>2</sub> correction average output> None O <sub>2</sub> correction O <sub>2</sub> correction average O <sub>2</sub> correction and O <sub>2</sub> correction average	note5																										
	None																											
	O <sub>2</sub> correction																											
	O <sub>2</sub> correction average																											
	O <sub>2</sub> correction and O <sub>2</sub> correction average																											
22	<Optional function (DIO)> FAULT   A. Cal.   H/L Alarm   RangeID/Remote range																											
	None																											
	○																											
	○																											
	○																											
	○																											
	○																											
	○																											
	○																											
	○																											
	○																											
	○																											
	○																											
	○																											
	○																											
	○																											
	○																											
	○																											
	○																											
	○																											
	○																											
	○																											
	○																											
	○																											
	○																											
	○																											
	○																											
	○																											
	○																											

## RANGE CODE

Range	Code	Range	Code
0~50ppm	A	0~5000ppm	H
0~100ppm	B	0~1vol%	J
0~200ppm	C	0~2vol%	K
0~250ppm	D	0~3vol%	Q
0~300ppm	S	0~5vol%	L
0~500ppm	E	0~10vol%	M
0~1000ppm	F	0~20vol%	N
0~2000ppm	G	0~25vol%	V
0~2500ppm	U	Others	Z
0~3000ppm	T		

## O<sub>2</sub> measurement range

Measurement range	Range code	Fuel cell O <sub>2</sub> analyzer (built - in)	Paramagnetic O <sub>2</sub> analyzer (built - in)	Zirconia O <sub>2</sub> analyzer (external)
0~5/10 vol%	A		○	○
0~5/25 vol%	B		○	○
0~10/25 vol%	C	○	○	○
0~5 vol%	L		○	○
0~10 vol%	M	○	○	○
0~25 vol%	V	○	○	○
0~50 vol%	P		○	
0~100 vol%	R		○	

- note1)When "D" is specified at 4th digit, Power supply cord is supplied in the scope of supply. Cord specification should be specified at the 20th digit.
- note2)When "1" is specified at 7th digit, O<sub>2</sub> pt analyzer signal has to be set as 0-1V DC linear corresponding to full scale. External zirconia O<sub>2</sub> analyzer and external O<sub>2</sub> analyzer are not included in the scope of supply, and has to be separately ordered.
- note3)Select the range code for each range from the range code table shown above. Range of fuel cell O<sub>2</sub> analyzer is 0-10vol% or more.
- note4)Select the type of voltage rating, plug type and applicable standard of the power supply cord by 20th digit. Select a power supply cord for using at the location of end-user.
- note5)O<sub>2</sub> correction is calculated only for NO, SO<sub>2</sub> and CO.
- note6)When 5 components measurement is specified, "H" must not be specified at 22nd digit. When 4 components measurement is specified and "H" is specified at 22nd digit, 3 points is maximum for alarm output function.
- note7)When "B" is specified at 24th digit, measuring range should be specified by ppm range code. In this case NO,SO<sub>2</sub> and CO measuring range are corresponding range in mg/m<sup>3</sup>. Please refer to the table shown below for the corresponding range code based on "mg/m<sup>3</sup>".
- note8)When "A" is specified at 25th digit, the analyzer will be adjusted and delivered with the balance gas N<sub>2</sub>. When other adjustment is required, please specify "Z". When "Z" is specified, please attach a list of gas composition contained in the measuring gas.

Corresponding mg/m<sup>3</sup>

Corresponding range in mg/m <sup>3</sup>				
Range code	Unit : ppm	NO	SO <sub>2</sub>	CO
A	0-50ppm	0-65.0mg/m <sup>3</sup>	0-140mg/m <sup>3</sup>	0-60.0mg/m <sup>3</sup>
B	0-100ppm	0-130mg/m <sup>3</sup>	0-280mg/m <sup>3</sup>	0-125mg/m <sup>3</sup>
C	0-200ppm	0-260mg/m <sup>3</sup>	0-570mg/m <sup>3</sup>	0-250mg/m <sup>3</sup>
D	0-250ppm	0-325mg/m <sup>3</sup>	0-700mg/m <sup>3</sup>	0-300mg/m <sup>3</sup>
S	0-300ppm	0-400mg/m <sup>3</sup>	0-850mg/m <sup>3</sup>	0-375mg/m <sup>3</sup>
E	0-500ppm	0-650mg/m <sup>3</sup>	0-1,400mg/m <sup>3</sup>	0-600mg/m <sup>3</sup>
F	0-1,000ppm	0-1,300mg/m <sup>3</sup>	0-2,800mg/m <sup>3</sup>	0-1,250mg/m <sup>3</sup>
G	0-2,000ppm	0-2,600mg/m <sup>3</sup>	0-5,600mg/m <sup>3</sup>	0-2,500mg/m <sup>3</sup>
U	0-2,500ppm	0-3,300mg/m <sup>3</sup>	0-7,100mg/m <sup>3</sup>	0-3,000mg/m <sup>3</sup>
T	0-3,000ppm	0-4,000mg/m <sup>3</sup>	0-8,500mg/m <sup>3</sup>	0-3,750mg/m <sup>3</sup>
H	0-5,000ppm	0-6,600mg/m <sup>3</sup>	0-14.00g/m <sup>3</sup>	0-6,250mg/m <sup>3</sup>

The conversion formula "ppm" unit into "mg/m<sup>3</sup>" unit.

NO (mg/m<sup>3</sup>) = 1.34 × NO (ppm)

SO<sub>2</sub> (mg/m<sup>3</sup>) = 2.86 × SO<sub>2</sub> (ppm)

CO (mg/m<sup>3</sup>) = 1.25 × CO (ppm)

## SCOPE OF DELIVERY

- Gas analyzer ... 1 unit
- Replacement fuse (250V, 2A AC, delay type) ... 2 pcs
- Instruction manual ... 1 copy
- Connector for I/O connection ... 1 set
- Power supply cord (standard inlet type 2m) ... 1 pc

## ORDERING INFORMATION

1. Code symbols
2. Application and composition of sample gas

# OUTLINE DIAGRAMS (Unit : mm)

<TOP VIEW>

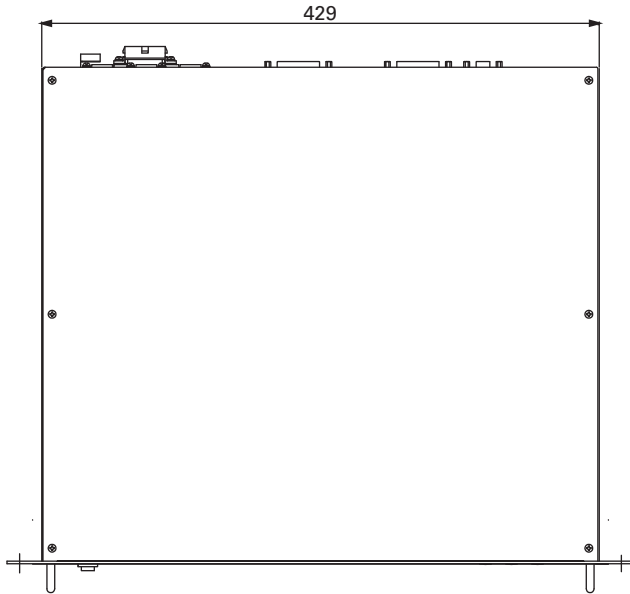

# Mounting method

The analyzer weight should be supported at the bottom of the case.

19-inch rack mounting type

<Rack dimensions>

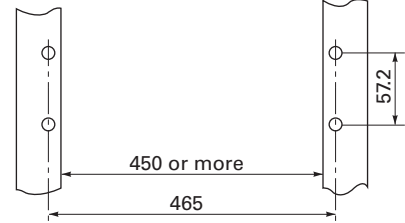

Mounting diagram

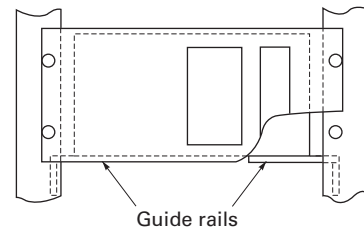
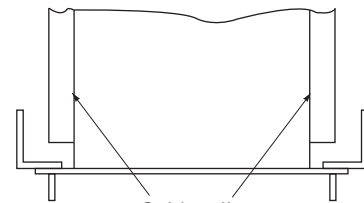

<FRONT VIEW>

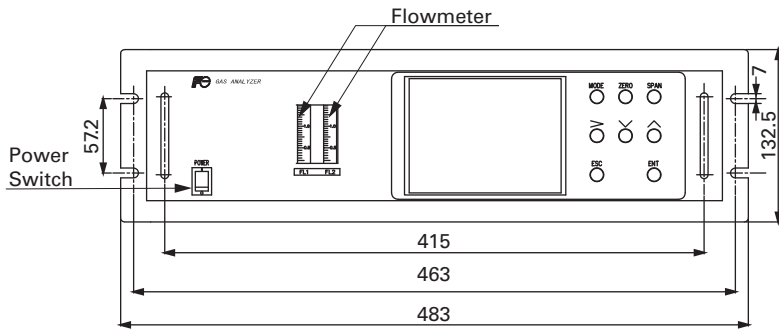

<REAR VIEW>

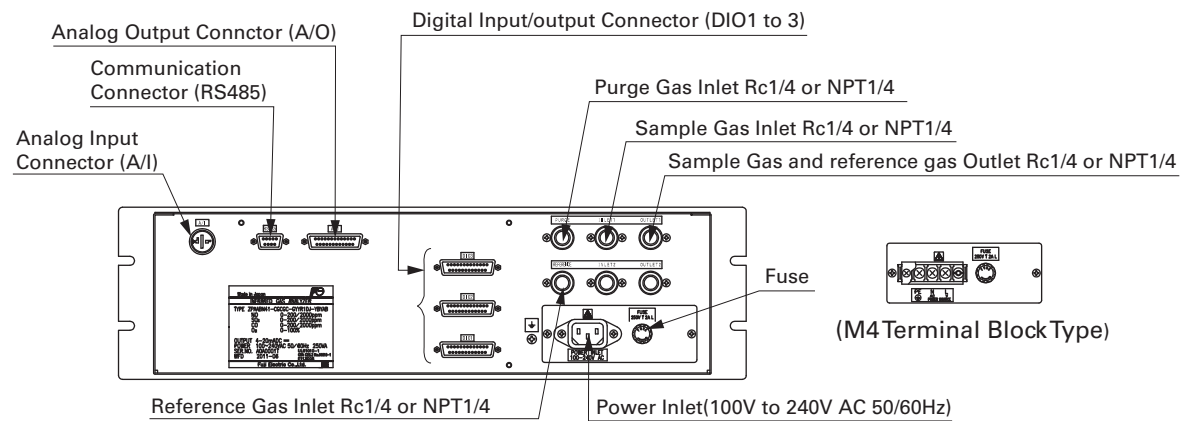

<SIDE VIEW>

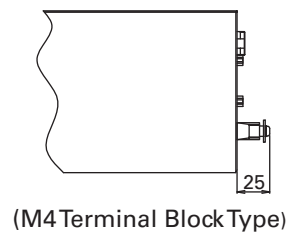
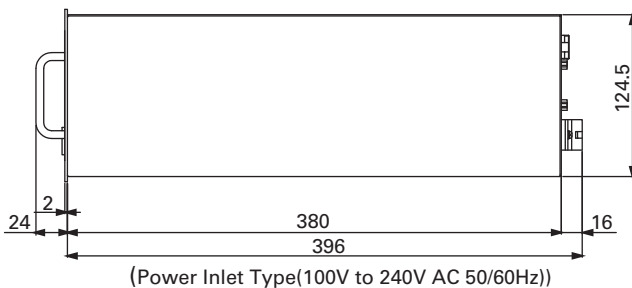

# EXTERNAL CONNECTION

<Analog output> A/O connector

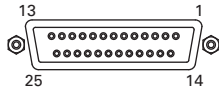

D-sub 25pins female

\* In standard, displayed Channel No. and Analog Output No. are same.

<Terminal block>

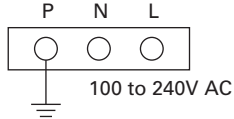

<Power inlet>

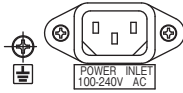

- ① AO1+
- ② AO1-
- ③ AO2+
- ④ AO2-
- ⑤ AO3+
- ⑥ AO3-
- ⑦ AO4+
- ⑧ AO4-
- ⑨ AO5+
- ⑩ AO5-
- ⑪ AO6+
- ⑫ AO6-
- ⑬ AO7+
- ⑭ AO7-
- ⑮ AO8+
- ⑯ AO8-
- ⑰ AO9+
- ⑱ AO9-
- ⑲ AO10+
- ⑳ AO10-
- ㉑ AO11+
- ㉒ AO11-
- ㉓ AO12+
- ㉔ AO12-
- ㉕ NC

<RS485 communication signal>

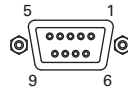

D-sub 9pins female

- ① (GND)
- ② RTxD+
- ③ RTxD-
- ④
- ⑤
- ⑥
- ⑦
- ⑧
- ⑨

<Analog input> A/I connector (O<sub>2</sub> signal input)

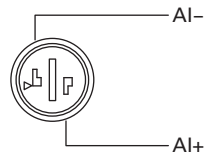

<Digital I/O> DIO 1 to 3 connector (option)

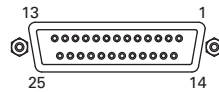

D-sub 25pins female

\* DIO 1 to 3 are all as same connector.

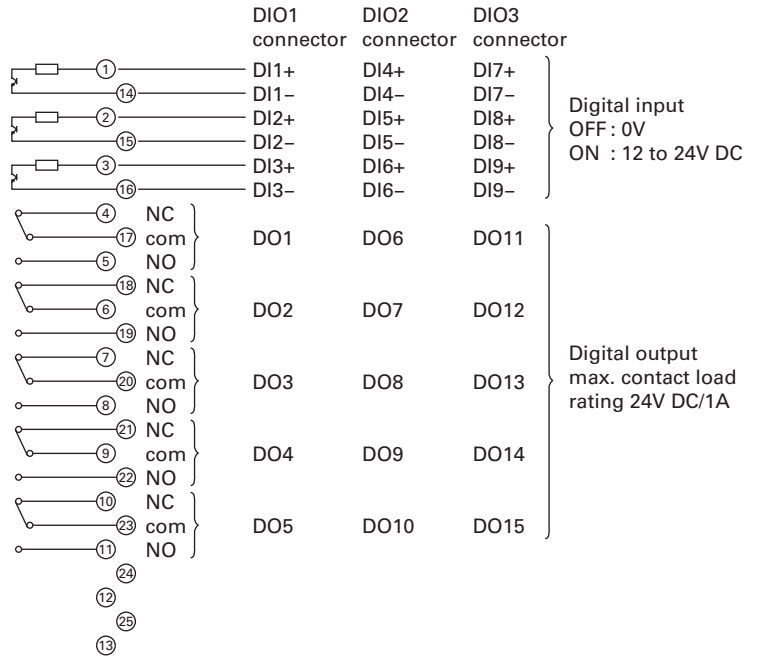

Contents of digital input signal

DI1	Remote hold
DI2	Average value reset
DI3	A. cal. start
DI4	A. zero. cal. start
DI5	Remote range Ch1
DI6	Remote range Ch2
DI7	Remote range Ch3
DI8	Remote range Ch4
DI9	Remote range Ch5

Allocation table of digital input signal

22th digit →	A	B	C	D	E	F	G	H	Y
DI1	○	○	○	○	○	○	○	○	
DI2	○	○	○	○	○	○	○	○	
DI3		○			○		○	○	
DI4		○			○		○	○	
DI5				○		○	○	○	
DI6				○*		○*	○*	○*	
DI7				○*		○*	○*	○*	
DI8				○*		○*	○*	○*	
DI9				○*		○*	○*	○*	

○ sign shows the function is valid.  
 \* : The function might be invalid depending on the number of measurable components.  
 For example: DI5 corresponds to 1st component, DI6 corresponds to 2nd components.

Contents of digital output signal

22th digit →	Independent on the number of component	1-component analyzer		2-component analyzer	3-component analyzer
		A, C	B, E	D, F, G, H	B, D, E, F, G, H
DO1	Instrument error	Instrument error	Instrument error	Instrument error	Instrument error
DO2	Calibration error	Calibration error	Calibration error	Calibration error	Calibration error
DO3		A.cal.status	(A.cal.status)	(A.cal.status)	(A.cal.status)
DO4		For zero gas	(For zero gas)	(For zero gas)	(For zero gas)
DO5		For span gas Ch1	(For span gas Ch1)	(For span gas Ch1)	(For span gas Ch1)
DO6	(Alarm1)	(Alarm1)		(For span gas Ch2)	(For span gas Ch2)
DO7	(Alarm2)	(Alarm2)			(For span gas Ch3)
DO8	(Alarm3)	(Alarm3)			(Range identification Ch1)
DO9	(Alarm4)	(Alarm4)		(Range identification Ch1)	(Range identification Ch2)
DO10	(Alarm5)	(Alarm5)	Range identification Ch1	(Range identification Ch2)	(Range identification Ch3)
DO11			(Alarm1)	(Alarm1)	(Alarm1)
DO12			(Alarm2)	(Alarm2)	(Alarm2)
DO13			(Alarm3)	(Alarm3)	(Alarm3)
DO14			(Alarm4)	(Alarm4)	(Alarm4)
DO15			(Alarm5)	(Alarm5)	(Alarm5)

The items in the parentheses may not be available depending on the selected type on 22th digit.

The normal open side (NO) of digital output is close when the function is active without range ID.

In case of range ID, normal open (NO) side is close with First-range.  
 The normal close (NC) side is close with Second-range.

22th digit →	4-component analyzer				5-component analyzer		
	B, E	D, F	G	H	B, E	D, F	G
DO1	Instrument error	Instrument error	Instrument error	Instrument error	Instrument error	Instrument error	Instrument error
DO2	Calibration error	Calibration error	Calibration error	Calibration error	Calibration error	Calibration error	Calibration error
DO3	A.cal.status		A.cal.status	A.cal.status	A.cal.status		A.cal.status
DO4	For zero gas		For zero gas	For zero gas	For zero gas		For zero gas
DO5	For span gas Ch1		For span gas Ch1	For span gas Ch1	For span gas Ch1		For span gas Ch1
DO6	For span gas Ch2		For span gas Ch2	For span gas Ch2	For span gas Ch2	Range identification Ch1	For span gas Ch2
DO7	For span gas Ch3	Range identification Ch1	For span gas Ch3	For span gas Ch3	For span gas Ch3	Range identification Ch2	For span gas Ch3
DO8	For span gas Ch4	Range identification Ch2	For span gas Ch4	For span gas Ch4	For span gas Ch4	Range identification Ch3	For span gas Ch4
DO9		Range identification Ch3		Range identification Ch1	For span gas Ch5	Range identification Ch4	For span gas Ch5
DO10		Range identification Ch4		Range identification Ch2		Range identification Ch5	
DO11	(Alarm1)	(Alarm1)		(Alarm1)	(Alarm1)	(Alarm1)	Range identification Ch1
DO12	(Alarm2)	(Alarm2)	Range identification Ch1	(Alarm2)	(Alarm2)	(Alarm2)	Range identification Ch2
DO13	(Alarm3)	(Alarm3)	Range identification Ch2	(Alarm3)	(Alarm3)	(Alarm3)	Range identification Ch3
DO14	(Alarm4)	(Alarm4)	Range identification Ch3	Range identification Ch3	(Alarm4)	(Alarm4)	Range identification Ch4
DO15	(Alarm5)	(Alarm5)	Range identification Ch4	Range identification Ch4	(Alarm5)	(Alarm5)	Range identification Ch5

## Component eliminator (Item to be prepared separately)

<Note before ordering>

Whether or not you need the eliminator, it is depend on using gas as relative gas as follows.

Regarding specification of component eliminator, please refer to Fuji's data sheet DS3-1 "sampling device series for gas analyzer"

### 1. When you use the air as relative gas

Measuring range	Code	Measurement component			
		NO sensor	SO <sub>2</sub> sensor	CO sensor	CO <sub>2</sub> sensor
0 - 50ppm	A	○	○	○	○ (*5)
0 - 100	B	○	×	○	
0 - 200	C	×	×	○	
0 - 250	D	×	×	○	
0 - 300	S	×	×	○	
0 - 500	E	×	×	○	
0 - 1,000	F	×	×	○	
0 - 2,000	G	×	×	×	
0 - 2,500	U	×	×	×	
0 - 3,000	T	×	×	×	
0 - 5,000	H	×	×	×	
0 - 1vol%	J				
0 - 2vol%	K				
0 - 3vol%	Q				
0 - 5vol%	L				
0 - 10vol%	M				
0 - 20vol%	N				
0 - 25vol%	V				

(\*1) Whether or not you need the eliminator, it is all depending on concentration of component to be measured in relative gas.

If gas concentration to be measured in relative gas is 0.1% FS or less of the range, component eliminator is not needed.

When concentration of the relative gas can not be comprehended correctly, please make sure to use the component eliminator as a general rule.

(\*2) About above list

Above list is assumed that air is used as relative gas (except CO<sub>2</sub> sensor)

Since air contains CO gas approx. 1.0ppm (\*4), component eliminator is needed if gas concentration to be measured in relative gas of the CO sensor is 1.0ppm/0.1% FS=1,000ppm or less according to (\*1)

Other measured component is same as shown on above list according to measurement authority in Tokyo.

(\*3) These are based on Tokyo public environment atmosphere measurement station and roadside automobile exhaust monitoring station.

(\*4) Since air contains CO<sub>2</sub> approx. 400ppm, it is not recommended to use air as relative gas to measure CO<sub>2</sub>.

Please meet the requirements as shown (\*1) such that using component eliminator after preparation of the lowest CO<sub>2</sub> concentration gas from available gas to be supplied continuously. Also, when measurement range is 100ppm or more, please use Fuji's inferred gas analyzer ZPA.

(\*5) When you specified several measurement components for ZPB, component eliminators are needed for each measured components.

However, one component eliminator can be used for both of No sensor and So<sub>2</sub> sensor.

### 2. When you use the N<sub>2</sub> as relative gas,

Whether or not you need the eliminator, it is all depending on concentration of component to be measured in relative gas.

If gas concentration to be measured in relative gas is 0.1% FS or less of the range, component eliminator is not needed.

When concentration of the relative gas can not be comprehended correctly, please make sure to use the component eliminator as a general rule.

## Exclusive Zirconia O<sub>2</sub> Analyzer (to be purchased separately)

For O<sub>2</sub> correction, the gas analyzer ZPB can accept linearized 0 to 1V DC signal from the O<sub>2</sub> analyzer calibrated 0 to 25% O<sub>2</sub> full scale. If the analyzer is not available, Fuji can supply exclusive Zirconia O<sub>2</sub> analyzer Model ZFK.

Measuring method:

Zirconia system

Measurable component and measuring range:

Measurable component		Range
O <sub>2</sub>	Oxygen	0 to 25vol%

- Repeatability: Within ± 0.5% of full scale
- Linearity: Within ± 1% of full scale
- Zero drift: Within ± 1% of full scale/week
- Span drift: Within ± 2% of full scale/week
- Response time: Approx. 20 seconds (for 90% response)
- Measured gas flow rate: 0.5 ± 0.25L / min

Remark: The Zirconia system, due to its principle, may produce a measuring error due to relative concentration versus the combustible O<sub>2</sub> gas concentration. Also, a corrosive gas (SO<sub>2</sub> of 250 ppm or more, etc.) may affect the life of the analyzer.

### OUTLINE DIAGRAM (Unit:mm)

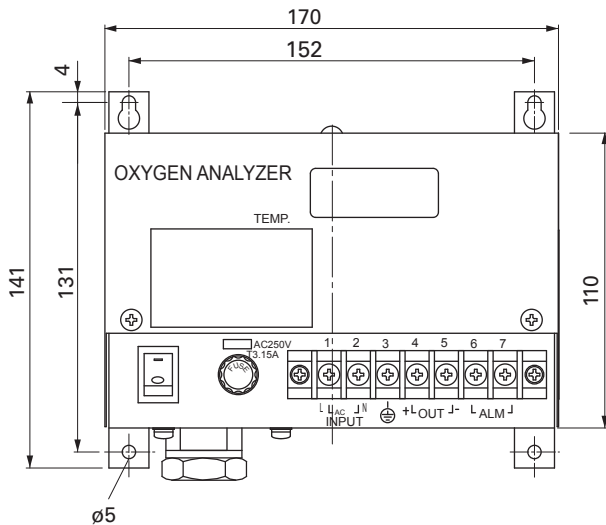

### EXTERNAL CONNECTION DIAGRAM

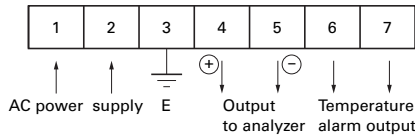

Gas inlet/outlet size:

Rc1/4 or NPT1/4

Power supply:

Rated voltage ; 100 to 115V AC or 200 to 240V AC

Rated frequency ; 50Hz/60Hz

Max. rated power ; 215VA (during power ON)  
65VA (during steady-state operation)

Enclosure:

Steel casing, for indoor application

Indication:

Temperature indication (LED)

Temperature alarm output:

Contact output 1a contact,  
Contact capacity 220V, 1A AC (resistive load)

Outer dimensions (H x W x D):

141 x 170 x 190mm

Mass {weight}:

Approx. 3kg

Finish color:

Munsell 5Y 7/1

### CODE SYMBOLS

1	2	3	4	5	6	7	8	9	10	11	12	13	Description	
Z	F	K	7	Y	Y	4	-	Y	0	Y	Y		Measuring method Zirconia method	
7YY														
								9						Power supply 100 to 115V AC 50/60Hz(Standard) 200 to 240V AC 50/60Hz(Standard) 200 to 240V AC 50/60Hz(CE mark)
								B						
								C						
								1						Gas inlet/outlet size Rc 1/4 NPT 1/4
								8						

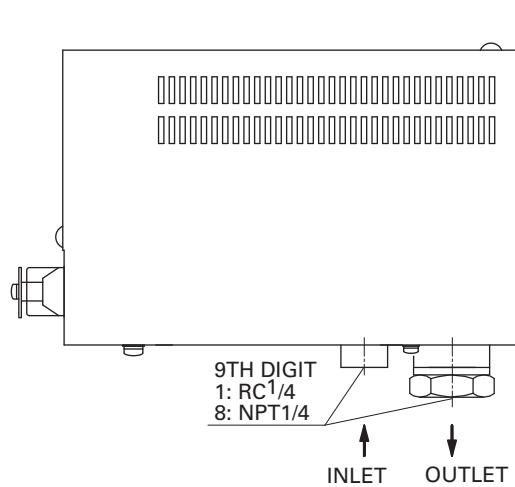

Information in this catalog is subject to change without notice.  
Read the instruction manuals thoroughly before using the products.

**F** Fuji Electric Co., Ltd.

Gate City Ohsaki, East Tower, 11-2, Osaki 1-chome, Shinagawa-ku, Tokyo 141-0032, Japan  
Phone: +81-3-5435-7111  
www.fujielectric.com  
www.fujielectric.com/products/instruments/