



Instruction Manual

NDIR TYPE INFRARED GAS ANALYZER

TYPE: ZRE-3



PREFACE

Thank you very much for purchasing Fuji's Infrared Gas Analyzer (Type: ZRE).

- Be sure to read this instruction manual carefully before performing installation, wiring, operation, and maintenance of the analyzer. Improper handling may result in accidents or injury.
- The specifications of this analyzer are subject to change without prior notice for further product improvement.
- Modification of this analyzer is strictly prohibited unless a written approval is obtained from the manufacturer. Fuji will not bear any responsibility for a trouble caused by such a modification.
- The person who actually operates the analyzer should keep this instruction manual.
- After reading through the manual, be sure to keep it near at hand for future reference.
- This instruction manual should be delivered to the end user without fail.

Manufacturer : Fuji Electric Co., Ltd.
Type : Described in the nameplate on main frame
Date of manufacture : Described in the nameplate on main frame
Country of manufacture : Japan

© Fuji Electric Co., Ltd. 2018

Issued in April, 2018
Rev. 1st edition June, 2022





Request



- No part or the whole of this manual may be reproduced without written permission of Fuji.
- Description in this manual is subject to change without prior notice for further improvement.

CAUTION ON SAFETY

To operate the analyzer properly, be sure to read “Caution on Safety” carefully.



- The descriptions listed here provide important information on safety. Be sure to observe them at all times. Those safety precautions are classified into 3 levels, “DANGER,” “CAUTION” and “PROHIBITION.”

 DANGER	Improper handling may cause dangerous situations that may result in death or serious injury.
 CAUTION	Improper handling may cause dangerous situations that may result in medium-level troubles, minor injury, or property damage.
 PROHIBITION	Items which must not be done are indicated.
 CAUTION	Items which indicates the possibility of receiving electric shock if it is handled incorrectly.



Caution on installation and transport of gas analyzer	
 DANGER	<ul style="list-style-type: none"> • The unit is not of explosion-proof specifications. Do not use it in an atmosphere of explosive gases. Otherwise, serious accidents such as explosion or fire may result.
 CAUTION	<ul style="list-style-type: none"> • For installation, observe the rule on it given in the instruction manual, and select a place where the weight of analyzer can be endured. Installation in an inadequate place may cause turnover or fall, resulting in injury. • Be sure to wear protective gloves when lifting the analyzer. Lifting it with bare hands may result in injury. • Be sure to fix the casing before transporting the analyzer. Transportation in unstable state may result in injury. • The gas analyzer is heavy. Two or more persons should carry it, while exercising due care. Otherwise, unexpected harm to your body or injury may result. • Take care not to let cable chips and other foreign objects enter the unit during installation work. Otherwise, fire, failure, or malfunction may result.

Caution on piping	
 DANGER	<p>Be sure to observe the following precautions while installing piping. Improper piping may result in gas leakage.</p> <p>If the leaking gas contains a toxic component, serious accidents may result. If it contains combustible gases, explosion or fire may result.</p> <ul style="list-style-type: none"> • Connect pipes correctly referring to the instruction manual. • Discharge the exhaust gas outdoors to prevent it from remaining within the sampling device or indoors. • Relieve the exhaust gas from the analyzer to the atmospheric pressure to prevent buildup of undesirable pressure to the analyzer. Otherwise, piping within the analyzer may be disconnected, resulting in gas leakage. • Use pipes and pressure reducing valves to which no oil/grease is attached to the piping. Otherwise, fire may result.

Caution on wiring	
 CAUTION	<ul style="list-style-type: none"> • Be sure to turn off the power before installing wiring. Otherwise, electric shock may result. • Be sure to perform protective earth connection. Otherwise, electric shock or failure may result. • Select a proper wiring material that satisfies the ratings of the instrument. Otherwise, electric shock or fire may result. • Be sure to connect a power supply of correct rating. Otherwise, fire may result.

Caution on use	
 DANGER	<ul style="list-style-type: none"> • Be sure to read the instruction manual for reference gases before handling reference gases such as calibration gas to use them properly.
 CAUTION	<ul style="list-style-type: none"> • Leaving the analyzer unused for a long time or restarting it after long-term suspension requires procedures different from normal operation or suspension procedures. Be sure to follow the instructions in each instruction manual. Otherwise, intended performance may not be achieved. Besides, accidents or injury may result. • Do not operate the analyzer for a long time with its door left open. Otherwise, dust, foreign matter, etc. may stick on internal walls, thereby causing faults.

Caution on use	
 PROHIBITION	<ul style="list-style-type: none"> • Do not touch the input/output terminals with metal or finger. Otherwise, electric shock or injury may result. • Do not smoke or use flames near the analyzer. Otherwise, fire may result. • Do not allow water to enter the analyzer. Otherwise, electric shock or internal fire may result.

Caution on maintenance and check	
 DANGER	<ul style="list-style-type: none"> • Before performing work with the cover of the analyzer kept open for maintenance and check, be sure to purge completely not only within the analyzer but also measuring gas lines with nitrogen or air. Otherwise, poisoning, fire, or explosion may result due to gas leakage.
 CAUTION	<p>Be sure to observe the following to perform work safely, avoiding electric shock or injury.</p> <ul style="list-style-type: none"> • Remove the watch and other metallic objects before work. • Do not touch the instrument with wet hands. • If the fuse is blown, eliminate the cause and replace it with the one of the same capacity and type. Otherwise, electric shock or accidents may result. • Do not use replacement parts other than those specified by the manufacturer. Otherwise, intended performance may not be achieved. Besides accidents or failures may result. • Dispose replacement parts such as maintenance parts as combustibles according to the local waste disposal regulations.

Others	
 CAUTION	<ul style="list-style-type: none"> • If the cause of any fault cannot be identified by referring to the instruction manual, be sure to contact your dealer or Fuji's technician in charge of adjustment. Disassembling the instrument carelessly may result in electric shock or injury.

CONTENTS

PREFACE.....	i
CAUTION ON SAFETY	ii
CONTENTS	v
1. OVERVIEW.....	1
2. NAME OF DELIVERED ITEMS AND EACH PARTS	2
2.1 Confirmation of delivered items	2
2.2 Name and description of analyzer.....	3
3. INSTALLATION	5
3.1 Installation conditions	5
3.2 Installation.....	6
3.2.1 Installation of analyzer main frame	6
3.3 Piping	7
3.4 Sampling	9
3.4.1 Conditions of sampling gas.....	9
3.4.2 Sampling gas flow.....	9
3.4.3 Preparation of standard gas.....	9
3.4.4 Purging of instrument inside	9
3.4.5 Pressure at sampling gas outlet.....	10
3.4.6 Example configuration of gas sampling system	10
3.5 Wiring.....	11
4. OPERATION	18
4.1 Preparation for operation	18
4.2 Warm-up operation and regular operation	18
5. DESCRIPTION OF DISPLAY AND OPERATION PANELS.....	19
5.1 Name and description of operation panel	19
5.2 Overview of display and operation panels.....	20
5.3 Outline of display screen.....	21
5.4 Basic operation.....	24
6. SETTING AND CALIBRATION.....	25
6.1 Switch of range	25
6.1.1 Setting of range switch mode.....	25
6.1.2 Manual range switch.....	26
6.2 Calibration setting.....	27
6.2.1 Setting of calibration concentration.....	27
6.2.2 Setting of manual zero calibration.....	29
6.2.3 Setting of calibration range.....	31
6.2.4 Setting of auto calibration component/range.....	32

6.3	Alarm setting.....	34
6.3.1	Setting of alarm values	34
6.3.2	Hysteresis setting	36
6.4	Setting of auto calibration	37
6.4.1	Auto calibration	37
6.4.2	Forced run/stop of auto calibration.....	40
6.5	Setting of auto zero calibration	42
6.5.1	Auto zero calibration	42
6.5.2	Forced run/stop of auto zero calibration.....	44
6.6	Parameter setting.....	46
6.7	Maintenance mode	52
6.8	Calibration.....	57
6.8.1	Zero calibration.....	57
6.8.2	Span calibration	58
7.	MAINTENANCE	59
7.1	Daily check	59
7.2	Daily check and maintenance procedures.....	59
7.3	Cleaning of sampling cell	60
7.3.1	Disassembly and assembly of sampling cell.....	60
7.3.2	How to clean cell	65
7.4	Cleaning of Enclosure.....	65
7.5	Adjustment in heat treatment furnace	66
8.	ERROR MESSAGE.....	68
9.	SPECIFICATIONS	71
9.1	General specifications	71
9.2	Code symbols.....	75
9.3	Outline diagram.....	77

1. OVERVIEW

This infrared gas analyzer (type: ZRE) has been tested to the requirements of UL 61010-1/CSA-C22.2 No.61010-1, second edition, including Amendment 1, or a later version of the same standard incorporating the same level of testing requirements.

This instrument measures the concentration of NO, SO₂, CO₂, CO and CH₄ contained in sampling gas on the principle that different atomic molecules have an absorption spectrum in the wave band of infrared rays, and the intensity of absorption is determined by the Lambert-Beer law.





Since this instrument incorporates a compact O₂ sensor, it allows measuring up to 5 components simultaneously by using the built-in O₂ sensor (up to 4 components if O₂ sensor is excluded).

Furthermore, use of a microprocessor and large sized liquid crystal display realizes improvement of operability, accuracy and multi-functions.

This instrument is optimum for measuring combustible gas exhausted from boilers or incinerators, and it is effective for steel gas analysis [blast furnace, steel converter, thermal treatment furnace, sintering (Pellet equipment), coke furnace], storage and maturity of vegetable and fruit, biochemistry (microbe), [fermentation], air pollution [incinerator, exhaust gas desulfurization, denitration], automotive emission (excluding tester), protection against disasters [detection of explosive gas and toxic gas, combustion gas analysis of new building material], growth of plants, chemical analysis [petroleum refinery plant, petroleum chemistry plant, gas generation plant], environment [land concentration, tunnel concentration, parking lot, building management] and various physical and chemical experiments.

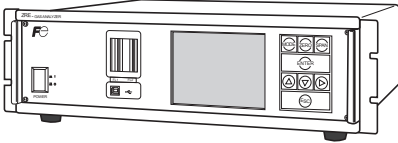
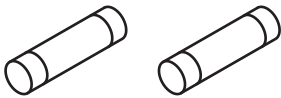
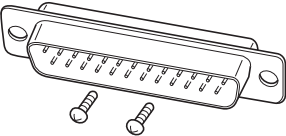
2. NAME OF DELIVERED ITEMS AND EACH PARTS

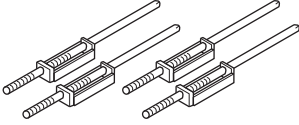
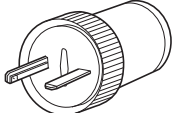
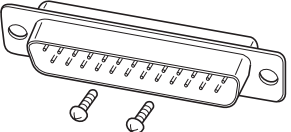
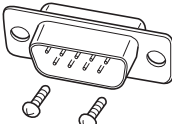
2.1 Confirmation of delivered items

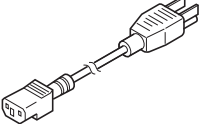
Analyzer: 1 unit		
Fuse: 2 pcs		Standard: IEC127-2 Size: $\phi 5 \times 20\text{mm}$ Rating: 250V/2A delay type Part No.: TK7L7571P3
Analog output connector: 1 Fixing screws: 2		25 pin D-sub connector (male) Part No.: TK7N3059P8 $M2.6 \times 4\text{mm}$
Instruction manual (this catalog): 1 copy (INZ-TN3ZREa-E) CD-ROM: 1 (When provided with communication function)		
Panel mounting bracket: 4 pcs (When panel mounting is specified)		Part No.: TK7N0904C1
External input connector: 1 (External O ₂ analyzer and External zirconia O ₂ analyzer are specified)		Part No.: TK7N3061P14
Digital input/output connector: 3 max. with the number of DIO Fixing screws: 6 max. (When digital input/output function is specified)		Max. 3 sets 25 pin D-sub connector (male) Part No.: TK7N3059P8 $M2.6 \times 4\text{mm}$
RS-485 connector: 1 Fixing screws: 2 (When provided with communication function)		9 pin D-sub connector (male) Part No.: TK7N3059P9 $M2.6 \times 4\text{mm}$
Ferrite core: 1 For power cable		Part No.: TK7N3059P5
Power cable: 1 (In case of UL model)		Standard inlet type

<In case of UL model>

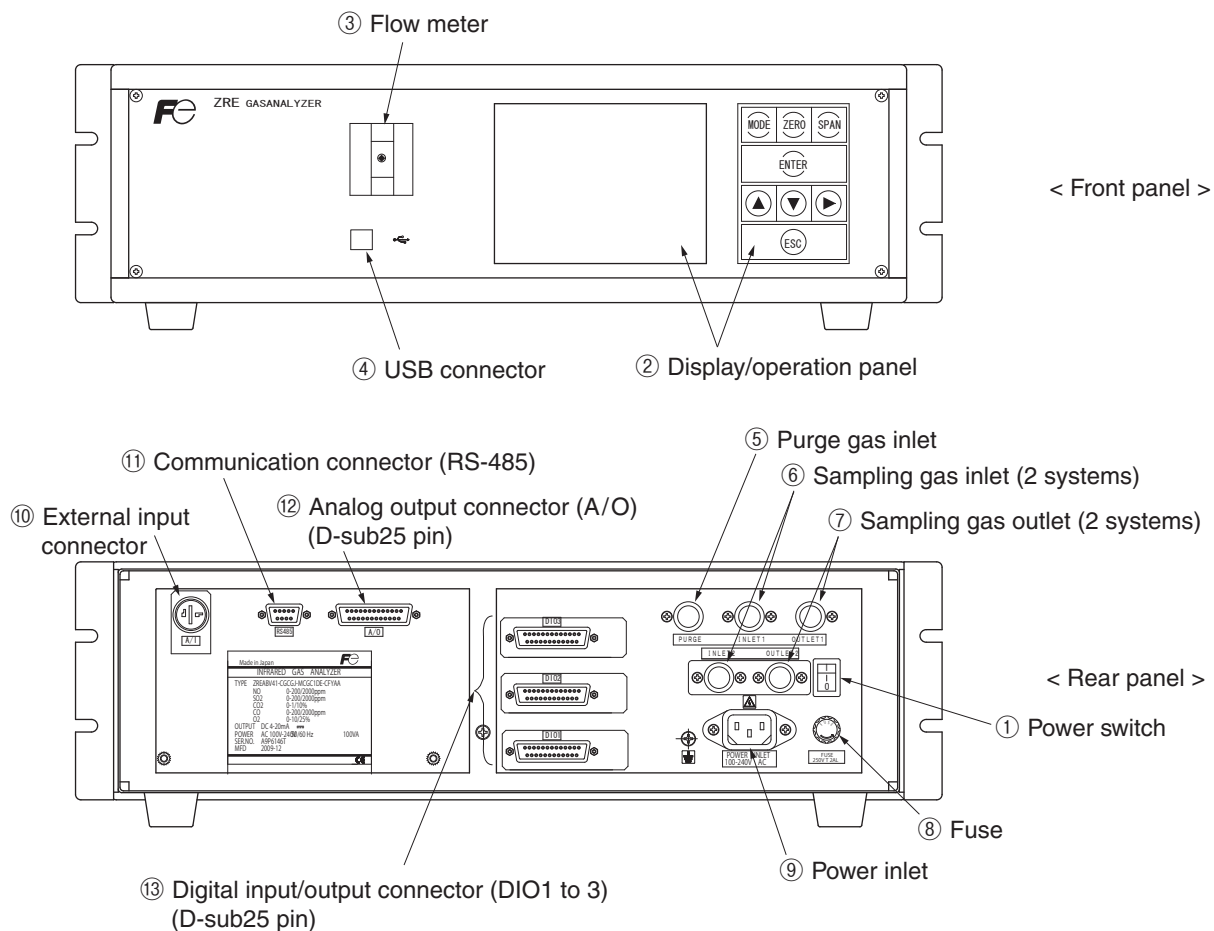

Fig. 2-2

Name	Description	Name	Description
① Power switch	Used for ON/OFF the analyzer.	⑧ Fuse	Fuse inside
② Display/operation panel	Liquid crystal display and keys for setting various functions.	⑨ Power inlet	For connecting to the power supply line.
③ Flow meter	For checking the flow rate of sampling gas.	⑩ External input connector	For connecting to the output of externally installed O ₂ analyzer.
④ USB connector	For connecting to the USB cable.	⑪ Communication connector	RS-485 connector for communication.
⑤ Purge gas inlet	For connecting to the purge gas tube.	⑫ Analog output connector (D-sub25 pin)	Connector for the analog output
⑥ Sampling gas inlet	For connecting to the measuring gas tube.	⑬ Digital input/output connector (D-sub25 pin)	Connector for the digital input/output
⑦ Sampling gas outlet	For connecting to the exhaust line.		

3. INSTALLATION

DANGER

This unit is not explosion-proof type. Do not use it in a place with explosive gases to prevent explosion, fire or other serious accidents.

CAUTION

- Entrust the installation, movement or re-installation to a specialist or the supplier. A poor installation may cause accidental tipover, electric shock, fire, injury, etc.
- The gas analyzer is heavy. It should be installed with utmost care. Otherwise, it may tipover or drop, for example, causing accident or injury.
- For lifting the gas analyzer, be sure to wear protective gloves. Bare hands may invite an injury.
- This unit should be installed in a place which conforms to the conditions noted in the instruction manual. Otherwise, it may cause electric shocks, fire or malfunction of the unit.
- During installation work, care should be taken to keep the unit free from entry of cable chips or other foreign objects. Otherwise, it may cause fire, trouble or malfunction of the unit.

3.1 Installation conditions

To install the analyzer for optimum performance, select a location that meets the following conditions;

- (1) This instrument is system built in type. This instrument should be used while embedded in a panel, locker, or enclosure of steel sheet.
- (2) Use this instrument indoors.
- (3) A vibration-free place
- (4) A place which is clean around the analyzer.
- (5) Power supply
 - Rated voltage : 100V to 240V AC
 - Operating voltage : 85V to 264V AC
 - Rated frequency : 50/60 Hz
 - Power consumption : 100 VA max.
- (6) Operation conditions
 - Ambient temperature : -5° to 45°C (max. 40°C when two optical units are used, and the power supply is more than 200V AC)
 - Ambient humidity : 90 % RH or less, no condensation
 - Altitude : Up to 2,187yard [2,000m]
 - Installation category : II
 - Pollution Degree : 2
- (7) A switch or a circuit-breaker should be installed in a building equipment.
- (8) A breaker should be installed near an analyzer where an operator can handle it easily.
- (9) A label saying that the “Breaker for the analyzer” should be labeled on a breaker.
- (10) The breaker rating should meet the analyzer rating and a breaker should be an approved product.
- (11) Do not install the analyzer to the place where it is difficult to handle the power supply cable.

3.2 Installation

3.2.1 Installation of analyzer main frame

Installation methods for the analyzer main unit are divided into 2 types;

(Unit : mm)

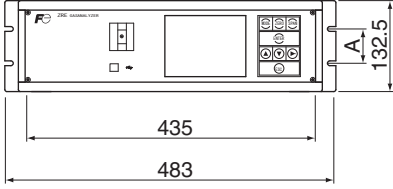
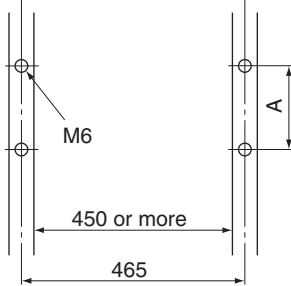
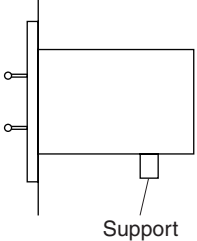
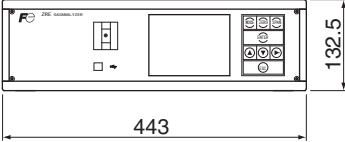
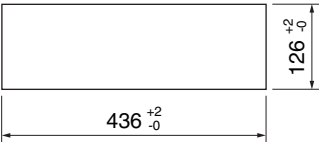
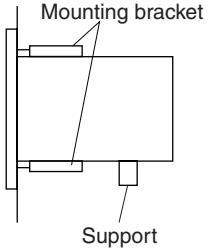
Type	External dimensions	Mounting dimensions	Mounting method
19-inch rack mounting	 <p>“A” : 57.2 (EIA) or 50 (JIS)</p>	 <p>“A” : 57.2 (EIA) or 50 (JIS)</p>	 <p>Support</p>
Panel mounting		<p>Panel cutout dimensions</p> 	 <p>Mounting bracket</p> <p>Support</p>

Note) • The analyzer weight should be supported at the bottom of the casing.

- The analyzer should be installed in a place where ambient temperature is within -5 to 45°C (max. 40°C when two optical units are used, and the power supply is more than 200V AC), and temperature fluctuation during using is minimum.
- Where vibration is unavoidable, protect the analyzer from vibrating.
For example, protection rubber is installed between the analyzer and support, or the analyzer's front panel and mounting panel.

3.3 Piping

CAUTION

In addition to a sample gas inlet and outlet, there is a purge gas inlet at the rear panel of the analyzer.

When improper connection is carried out here, combustible gas, poisonous gas, and explosive fumes may be accumulated into the analyzer.

Observe the following when connecting the gas tube.

- Piping should be connected to the gas inlets and outlets at the rear panel of the analyzer.
- Use a corrosion resistant tube of Teflon, stainless or polyethylene to connect the instrument to a sampling system. Even if there is a danger of corrosion, refrain from using a tube of rubber or soft vinyl. The instrument provides inaccurate indication due to gas absorption by piping materials.
- Pipe connection port is Rc1/4 female thread (or NPT1/4). Piping should be cut as short as possible for a quick response. About 4 mm inner diameter is recommended.
- Entry of dust into the instrument may result in defective operation. Use a clean piping or coupling.

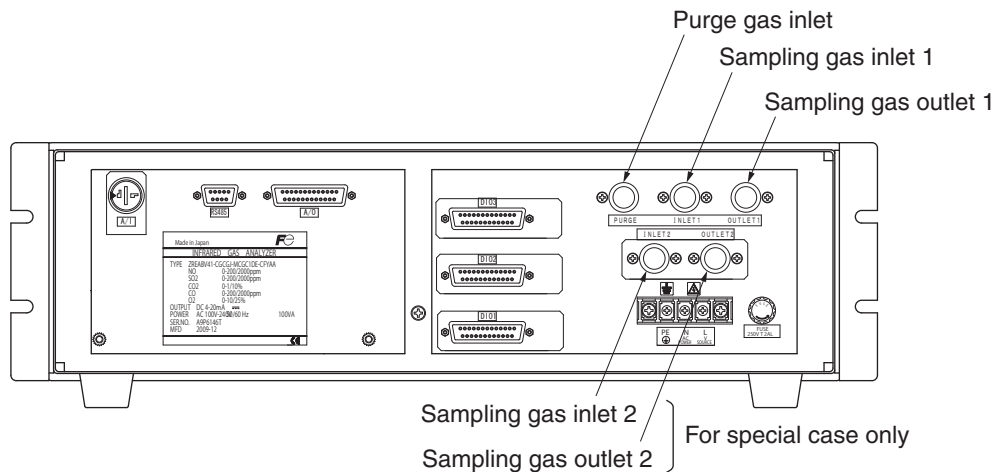

Sampling gas inlet: Attach the gas tube to introduce gas to be measured such as one that has completed dehumidification process and standard gases for zero and span calibration to this inlet.
Gas flow to be introduced should be constant within the range of 0.5 L/min \pm 0.2 L/min.

Sampling gas outlet: Exhaust measured gas through the outlet. Attach the tube to exhaust measured gas outdoors or to the atmosphere.

Purge gas inlet: It is used for purging the inside of the total gas analyzer.
Use dry gas N₂ or instrumentation air for purge gas. (Flow rate is 1L/min or more, and dust or mist is unallowable.)

Internal piping diagram

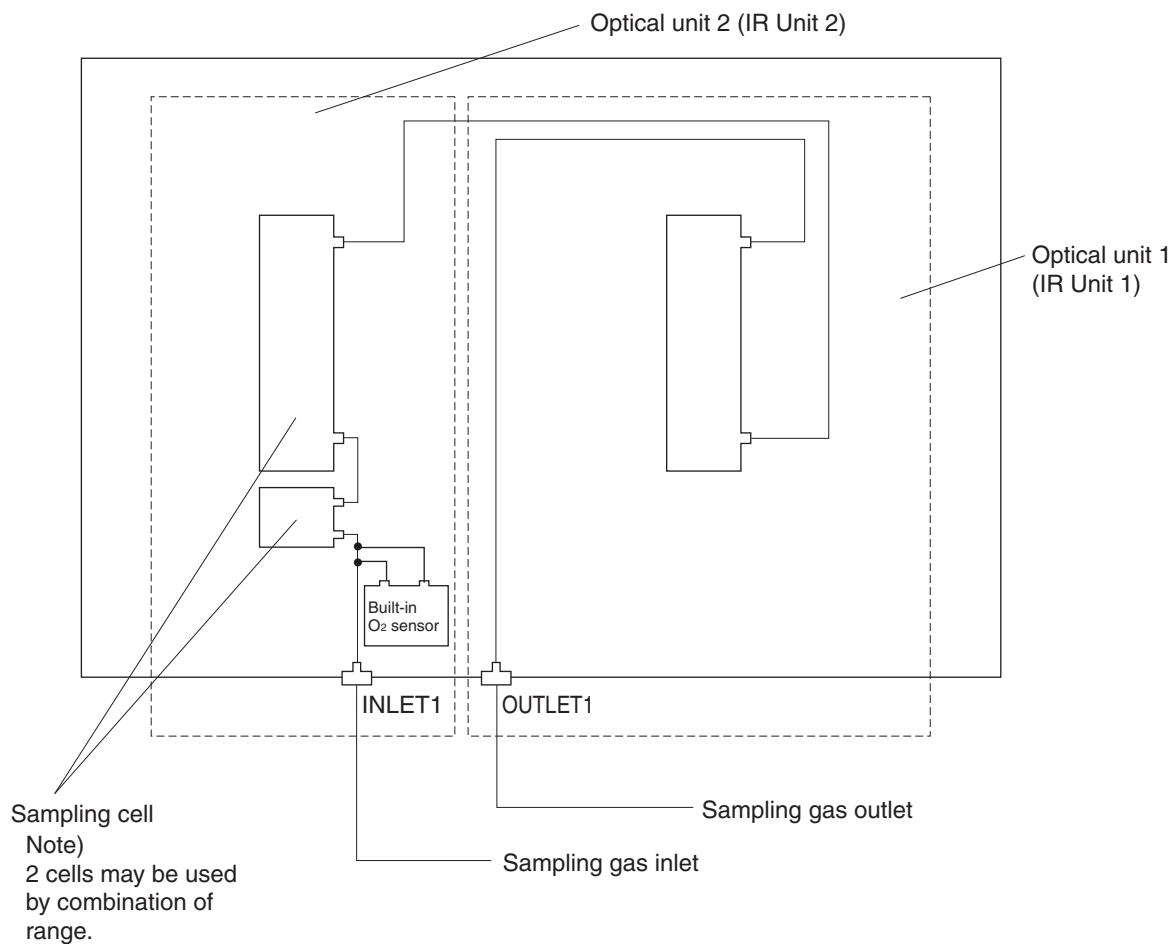

Correspondence of measured components and optical units

Measuring components	Optical unit 1	Optical unit 2
1-component for NO, SO ₂ , CO ₂ , CO and CH ₄	Each component	None
2-components for CO ₂ /CO	CO ₂ /CO	None
2-components for NO/CO, NO/SO ₂	NO NO	CO SO ₂
3-components for NO/SO ₂ /CO	NO	SO ₂ /CO
4-components for NO/SO ₂ /CO ₂ /CO	NO/CO	SO ₂ /CO ₂

3.4 Sampling

3.4.1 Conditions of sampling gas

- (1) Dust contained in the sampling gas should be completely removed with a filter. For the final stage filter, use a filter that allows removing dust particles of $0.3\mu\text{m}$.
- (2) Dew point of the sampling gas must be lower than the ambient temperature to avoid occurrence of drain in the gas analyzer. If vapor is contained in the sampling gas, dew point should be lowered to 2°C by using a dehumidifier.
- (3) If SO_3 mist is contained in the sampling gas, use a mist filter or cooler to remove SO_3 mist. Other mists should be removed by using a mist filter or gas dryer.
- (4) Corrosive gases such as Cl_2 , F_2 and HCl , if they are contained in the sampling gas in considerable amounts, will shorten the life of instruments.
- (5) Temperature of the sampling gas should be within 0 to 50°C . Pay attention not to flow hot gas directly into the instrument.

3.4.2 Sampling gas flow

Flow of sampling gas should be $0.5\text{L}/\text{min} \pm 0.2\text{L}/\text{min}$.

Avoid flow fluctuation during measurement.

Observe the flow reading by a flowmeter provided as shown in the example of the sampling system configuration (Item 3.4.6).

3.4.3 Preparation of standard gas

Routine calibration is required by standard gas for keeping this instrument under normal operation condition (once a week). Prepare a standard gas cylinder for zero calibration and span calibration.

	Analyzer without O_2 measurement	Analyzer with built-in O_2 sensor	Analyzer with external zirconia O_2 sensor
Zero gas	N_2 gas	N_2 gas	Dry air
Span gas other than for O_2 measurement	Gas with concentration of 90% or more of full scale	Gas with concentration of 90% or more of full scale	Gas with concentration of 90% or more of full scale
Span gas for O_2 measurement	_____	Gas with concentration of 90% or more of full scale or atmospheric air (21%)	O_2 gas of 1 to 2%

3.4.4 Purging of instrument inside

The inside of instrument need not be purged generally except for the following cases.

- (1) A combustible gas component is contained in the sample gas.
- (2) Corrosive gas is contained in the atmospheric air at the installation site.
- (3) The same gas as the sample gas component is contained in the atmospheric air at the installation site.

In such cases as above, the inside of analyzer should be purged with the air for instrumentation or dry N_2 .

Purging flow rate should be about $1\text{L}/\text{min}$.

If dust or mist is contained in purging gas, it should be eliminated completely in advance.

3.4.5 Pressure at sampling gas outlet

Pressure at the sampling gas outlet should be adjusted to the atmospheric pressure.

3.4.6 Example configuration of gas sampling system

The following illustrates a typical system configuration for five component gas measurement for monitoring combustion exhaust gas from boiler, refuse incinerator, etc.

Contact Fuji Electric for system configuration matching the particular use or further information.

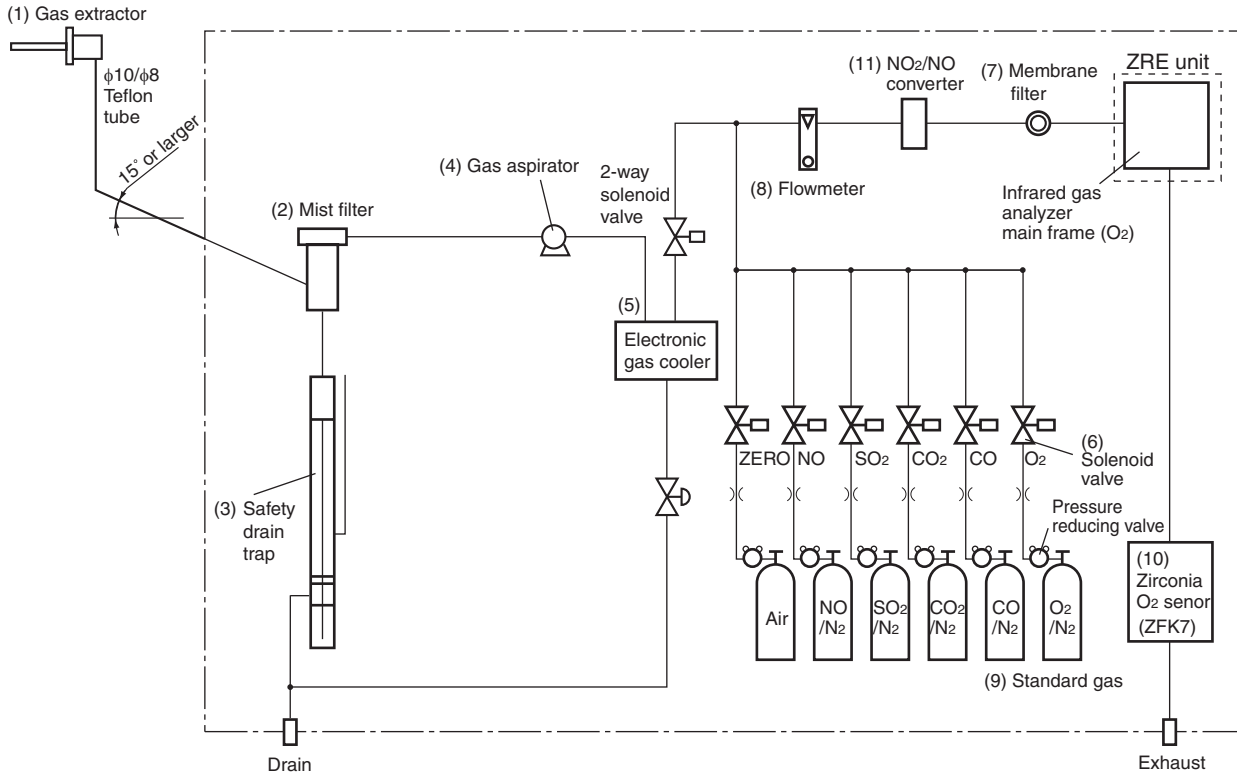

Name	Description	Name	Description
(1) Gas extractor	Gas extractor with a heating type stainless steel filter of standard mesh 40 μ m	(8) Flowmeter	Adjusts and monitors the flow rate of the sample gas.
(2) Mist filter	Removes drain, mist, and dust.	(9) Standard gas	Reference gas used for calibrating zero and span of the analyzer, depending on the measured gas.
(3) Safety drain trap	The safety drain trap is divided into two rooms for positive and negative pressure. It monitors and adjusts the sample gas pressure.	(10) Zirconia O ₂ sensor	External zirconia oxygen sensor used for measuring the oxygen concentration in sample gas. (This is not necessary in case when O ₂ sensor is built-in.)
(4) Gas aspirator	For aspiration of the sample gas	(11) NO ₂ /NO converter	Added to NO _x analyzer. A special catalyst material for efficient conversion of NO ₂ gas to NO is used.
(5) Electronic gas cooler	Dries the moisture in the sample gas to a dew point of approx. 2°C.		
(6) Solenoid valve	Used for introducing the calibration gas.		
(7) Membrane filter	PTFE filter used to eliminate fine dust particles.		

3.5 Wiring

⚠ CAUTION

- Be sure to turn off the power before installing wiring. Otherwise, electric shock may result.
- Be sure to perform protective earth connection. Otherwise, electric shock or failure may result.
- Select a proper wiring material that satisfies the ratings of the instrument. Otherwise, electric shock or fire may result.
- Be sure to connect a power supply of correct rating. Otherwise, fire may result.
- Do not use the power supply cable which does not meet the rating of analyzer.

⚠ DANGER

⚡ Electric Shock

Please be sure to make ground (grounding) connection for safety.

The power terminal block and external input/output connector is provided at the rear panel. Refer to the following.

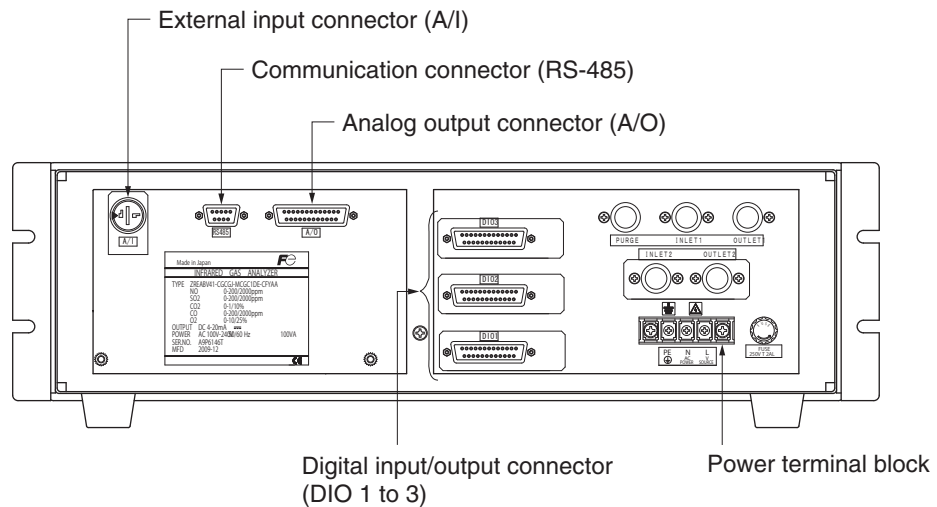

(1) Power supply (standard terminal 1 to 2)

Connect the given power supply to the power terminal, and connect the ground wire to the grounding terminal (standard terminal 3). Be sure to perform protective earth connection. Use solderless terminals (for M3.5) for connection to the terminals (power and earth).

The infrared gas analyser: Please install an accessory ferrite core (To the power supply terminal stand side) on the power supply wiring line of ZRE. Application line diameter $\phi 9.5$ to $\phi 10.5$

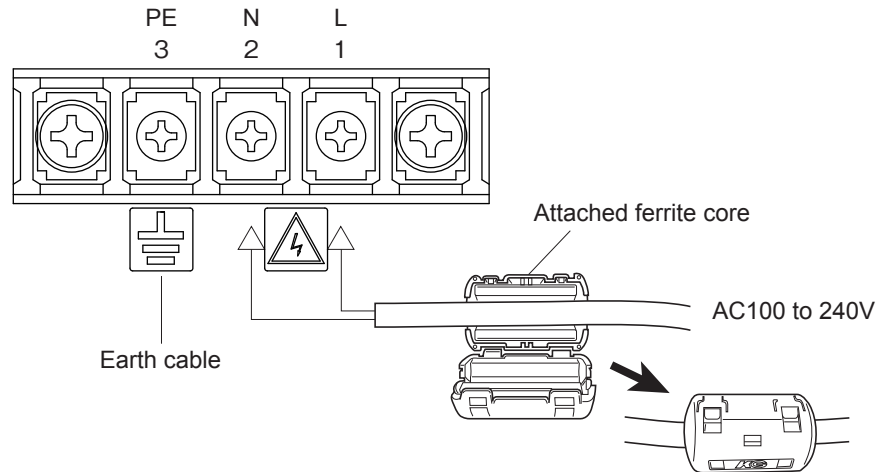

CAUTION

After the wiring work, be sure to place the protective cover for the terminal blocks to assure safety.

<In case of UL model>

Power supply (power inlet)

The power inlet is provided at the rear panel. Connect supplied power cable to this AC inlet.

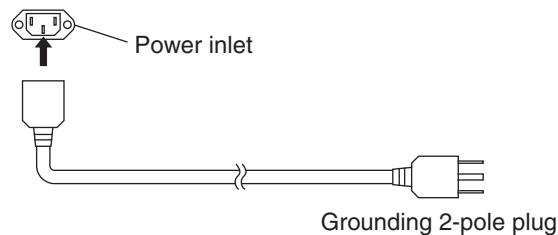

When noise source is in the vicinity

- Avoid installing this instrument near an electrical unit (high frequency furnace or electric welder) that generates much electrical noise. If using the instrument near such a noise generating unit is unavoidable, use a different power line to avoid noise.
- Mount a noise suppressor such as varistor or spark killer as shown at right figure to the noise generating unit when noise is generated from relays or solenoid valves. Mount the suppressor near the noise generating source, or it will have no effect.

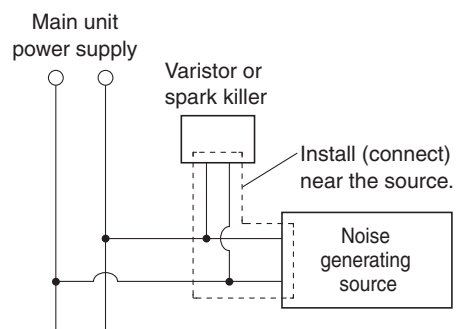

(2) Analog output signal: Analog output connector (A/O)

Output signal : 4 to 20 mA DC or 0 to 1 V DC (selected when ordering)

Minus lines for the insulation and signal are common from the ground and internal circuit

Allowable load: 4 to 20 mA DC, 550Ω or less

0 to 1 V DC, 100kΩ or more

< Analog output > A/O connector

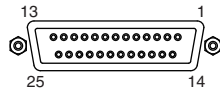

D-sub 25-pin female

Note) Display Ch number is same as the AO number under standard specifications.

①	AO1+
⑭	AO1-
②	AO2+
⑮	AO2-
③	AO3+
⑯	AO3-
④	AO4+
⑰	AO4-
⑤	AO5+
⑱	AO5-
⑥	AO6+
⑲	AO6-
⑦	AO7+
⑳	AO7-
⑧	AO8+
㉑	AO8-
⑨	AO9+
㉒	AO9-
⑩	AO10+
㉓	AO10-
⑪	AO11+
㉔	AO11-
⑫	AO12+
㉕	AO12-
⑬	NC

All the analog output signals of the instrument are not isolated individually. It is recommended to isolate the signals individually to eliminate the interference from the unnecessary signals or the effect of external interference, especially leading the cable of more than 30 meters or to outdoor.

(3) O₂ sensor input: External input connector (A/I)

Input signal:

External zirconia O₂ analyzer : Zirconia O₂ sensor signal (Fuji ZFK7 output)

External O₂ analyzer : 0 to 1 V DC (DC input resistor of 1MΩ or more)

< External input > A/I connector (O₂ sensor input)

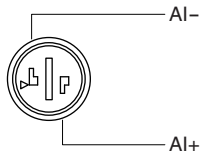

- It is used when the external zirconia O₂ analyzer or the external O₂ analyzer is specified as order.
- Connect the dedicated connector (accessory) to the output of the external Zirconia analyzer or the external O₂ analyzer prepared separately.
- In case of an external O₂ analyzer, input a signal of 0 to 1 V DC with respect to O₂ full scale of the analyzer. The O₂ concentration display, output, and O₂ correction can be performed.
- Do not connect when the built-in O₂ analyzer is installed.

O₂ sensor input is not isolated. It is recommended to isolate when an external O₂ analyzer is installed apart from this analyzer. Zirconia O₂ sensor (Fuji ZFK7) should be installed at a location that is as close to this instrument as possible.

* How to connect the O₂ signal to the dedicated connector (accessory).

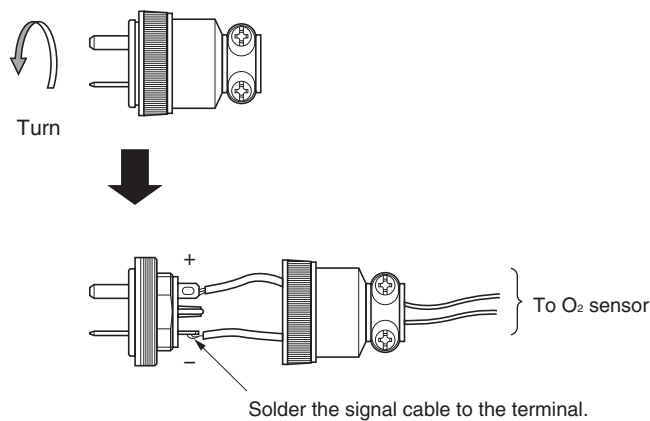

(4) Contact input/output (DIO): digital input/output connector (DIO1 to 3)

Contact input signal : Voltage is applied from the external 12 to 24 V DC, max 15mA
Photo-coupler insulation (from each DI and ground)

Contact capacity : C contact relay output 24V/1A AC/DC resistive load

< Digital input/output > Connector for DIO 1 to 3 (option)

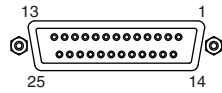

D-sub 25-pin female

Note) DIO 1 to 3 have the same internal circuit of the connector.

Contents of digital input signal

DI1	Remote hold
DI2	Average value reset
DI3	A. cal. start
DI4	A. zero. cal. start
DI5	Remote range Ch1
DI6	Remote range Ch2
DI7	Remote range Ch3
DI8	Remote range Ch4
DI9	Remote range Ch5

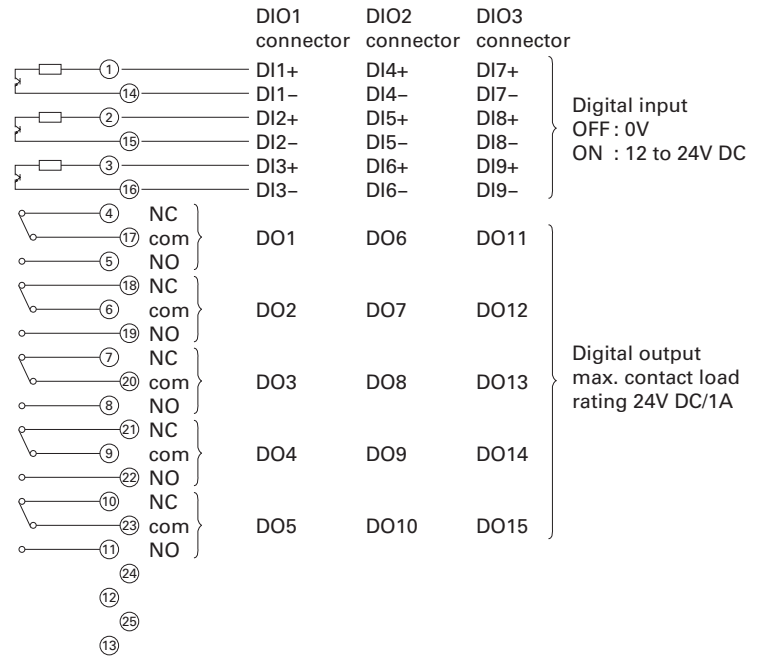

Contents of digital output signal

	Independent on the number of component	1-component analyzer		2-component analyzer	3-component analyzer
22th digit →	A,C	B,E	D,F,G,H	B,D,E,F,G,H	B,D,E,F,G,H
DO1	Instrument error	Instrument error	Instrument error	Instrument error	Instrument error
DO2	Calibration error	Calibration error	Calibration error	Calibration error	Calibration error
DO3		A.cal.status	(A.cal.status)	(A.cal.status)	(A.cal.status)
DO4		For zero gas	(For zero gas)	(For zero gas)	(For zero gas)
DO5		For span gas Ch1	(For span gas Ch1)	(For span gas Ch1)	(For span gas Ch1)
DO6	(Alarm1)	(Alarm1)		(For span gas Ch2)	(For span gas Ch2)
DO7	(Alarm2)	(Alarm2)			(For span gas Ch3)
DO8	(Alarm3)	(Alarm3)			(Range identification Ch1)
DO9	(Alarm4)	(Alarm4)		(Range identification Ch1)	(Range identification Ch2)
DO10	(Alarm5)	(Alarm5)	Range identification Ch1	(Range identification Ch2)	(Range identification Ch3)
DO11			(Alarm1)	(Alarm1)	(Alarm1)
DO12			(Alarm2)	(Alarm2)	(Alarm2)
DO13			(Alarm3)	(Alarm3)	(Alarm3)
DO14			(Alarm4)	(Alarm4)	(Alarm4)
DO15			(Alarm5)	(Alarm5)	(Alarm5)

The items in the parentheses may not be available depending on the selected type on 22th digit.

The normal open side (NO) of digital output is close when the function is active without range ID.

In case of range ID, normal open (NO) side is close with Lo-range.

The normal close (NC) side is close with Hi-range.

	4-component analyzer				5-component analyzer		
22th digit →	B,E	D,F	G	H	B,E	D,F	G
DO1	Instrument error	Instrument error	Instrument error	Instrument error	Instrument error	Instrument error	Instrument error
DO2	Calibration error	Calibration error	Calibration error	Calibration error	Calibration error	Calibration error	Calibration error
DO3	A.cal.status		A.cal.status	A.cal.status	A.cal.status		A.cal.status
DO4	For zero gas		For zero gas	For zero gas	For zero gas		For zero gas
DO5	For span gas Ch1		For span gas Ch1	For span gas Ch1	For span gas Ch1		For span gas Ch1
DO6	For span gas Ch2		For span gas Ch2	For span gas Ch2	For span gas Ch2	Range identification Ch1	For span gas Ch2
DO7	For span gas Ch3	Range identification Ch1	For span gas Ch3	For span gas Ch3	For span gas Ch3	Range identification Ch2	For span gas Ch3
DO8	For span gas Ch4	Range identification Ch2	For span gas Ch4	For span gas Ch4	For span gas Ch4	Range identification Ch3	For span gas Ch4
DO9		Range identification Ch3		Range identification Ch1	For span gas Ch5	Range identification Ch4	For span gas Ch5
DO10		Range identification Ch4		Range identification Ch2		Range identification Ch5	
DO11	(Alarm1)	(Alarm1)		(Alarm1)	(Alarm1)	(Alarm1)	Range identification Ch1
DO12	(Alarm2)	(Alarm2)	Range identification Ch1	(Alarm2)	(Alarm2)	(Alarm2)	Range identification Ch2
DO13	(Alarm3)	(Alarm3)	Range identification Ch2	(Alarm3)	(Alarm3)	(Alarm3)	Range identification Ch3
DO14	(Alarm4)	(Alarm4)	Range identification Ch3	Range identification Ch3	(Alarm4)	(Alarm4)	Range identification Ch4
DO15	(Alarm5)	(Alarm5)	Range identification Ch4	Range identification Ch4	(Alarm5)	(Alarm5)	Range identification Ch5

- Insulation output (from each DO and ground)

To avoid external interference, wiring of analog output signal, O₂ sensor input and contact input should be fixed separately from that of power supply and contact output.

Note) To avoid the effect of noise generated from external units, be sure to ground the analyzer main unit.

(5) Communication: RS-485/USB connector

< RS-485 connector >

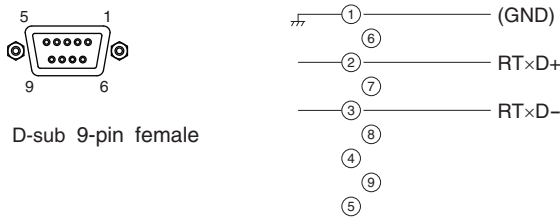

< USB > TYPE-B connector

(6) Timing of contact output for calibration

1) Manual calibration (See “Item 6.8 Calibration”.) (When the analyzer has auto calibration function.)

- Zero calibration

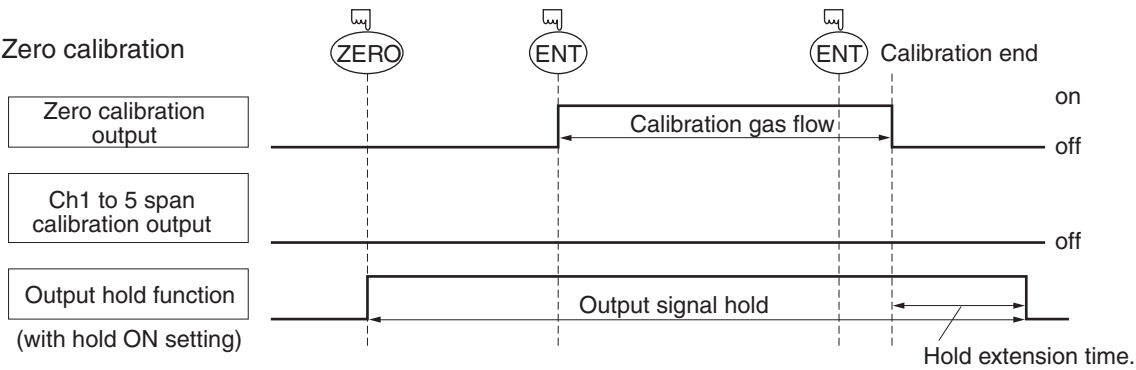

- Span calibration

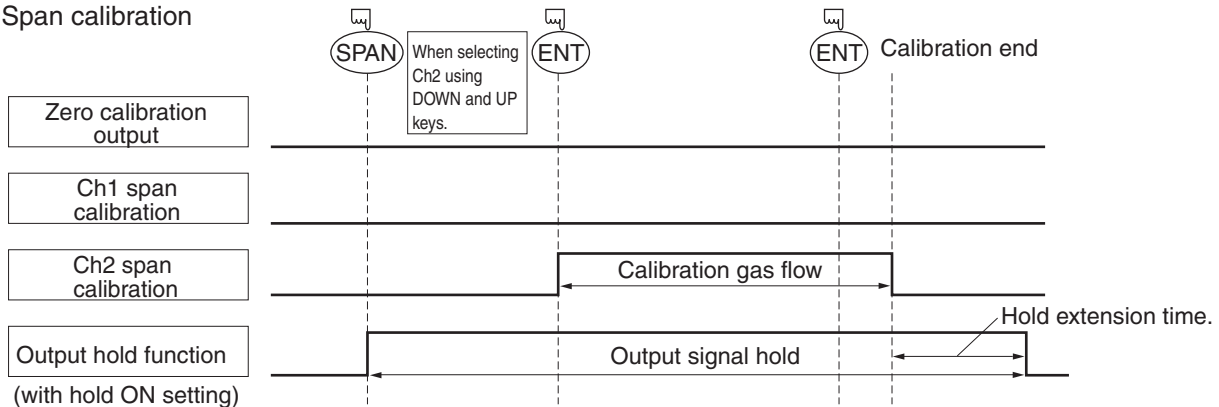

Note) The hold extension time depends on the gas flow time of the automatic calibration settings.

2) In case of automatic calibration
(example shown in Item 6.4.1, Automatic calibration settings)

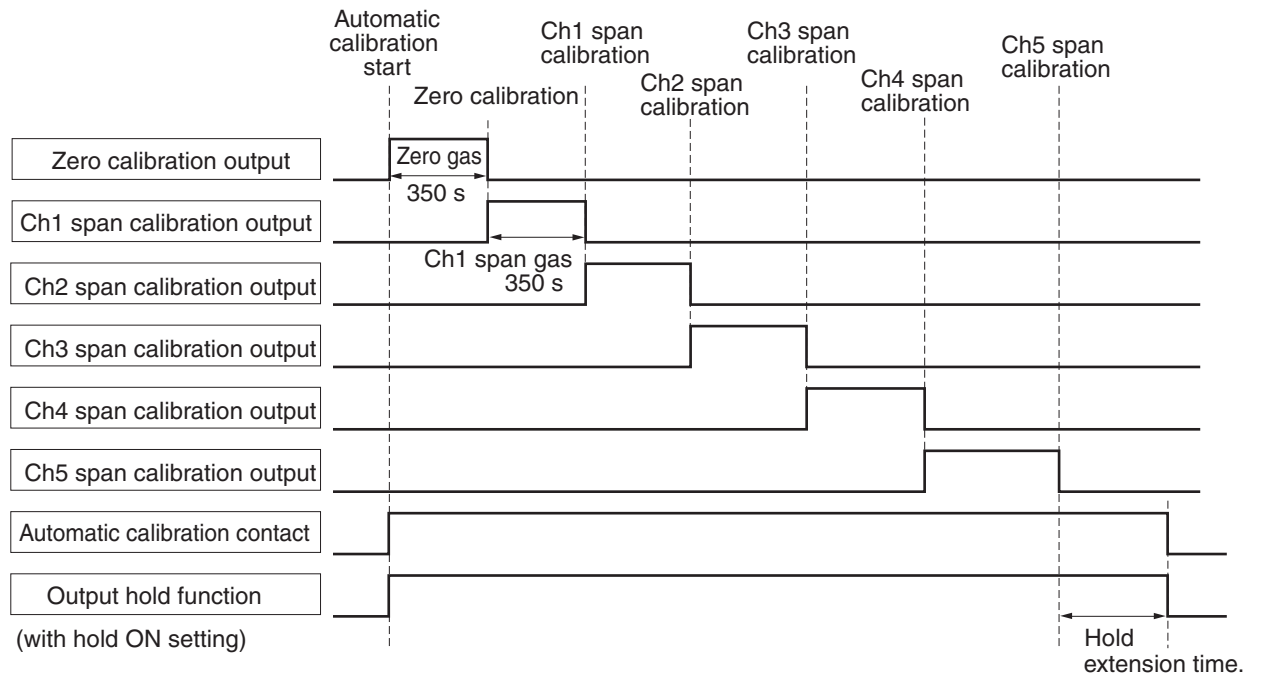

4. OPERATION

4.1 Preparation for operation

(1) Tube and wiring check

Double-check if tubes of the gas sampling and exhaust ports are correctly connected.

Double-check for proper wiring.

4.2 Warm-up operation and regular operation

(1) Operation procedure

- 1) Turn ON the power switch on the left side when facing the front panel of the analyzer unit.
The measurement screen appears on the front display panel in 1 to 2 seconds.
<In case of UL model>
Turn ON the power switch on the right side when facing the rear panel of the analyzer unit.
- 2) Wait for about 4 hours until the instrument is warmed up.
About 4 hours are required until the instrument allows accurate measurement.

Note) When in warm-up, the concentration reading may be beyond.

 **upper limit of range.**

But, it is not an error.

- 3) Setting of various set values
Perform the various settings according to “Item 6. Setting and Calibration”.
- 4) Zero calibration and span calibration
Perform zero/span calibration after warm-up operation.
Refer to “Item 6.8 Calibration”.
- 5) Introduction and measurement of measuring gas
Introduce the measuring gas into the analyzer unit before starting measurement.

5. DESCRIPTION OF DISPLAY AND OPERATION PANELS

This section describes the display unit and operation panel of the analyzer unit. It also explains the name and description of function on the operation panel.

5.1 Name and description of operation panel

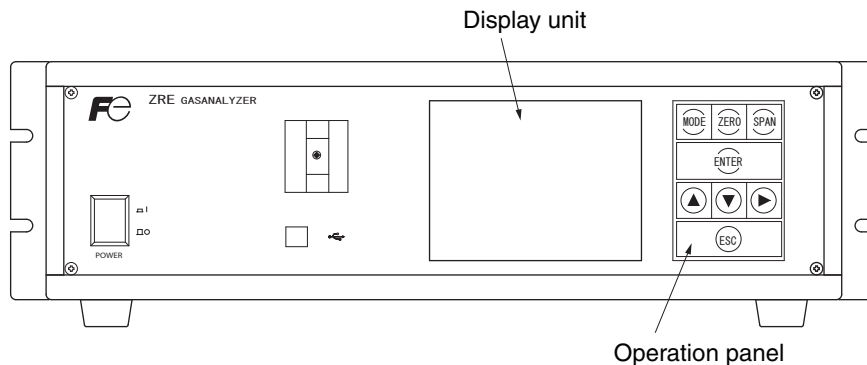

- Display unit: The measurement screen and the setting items are displayed.
- Operation panel: The configuration is as shown below.

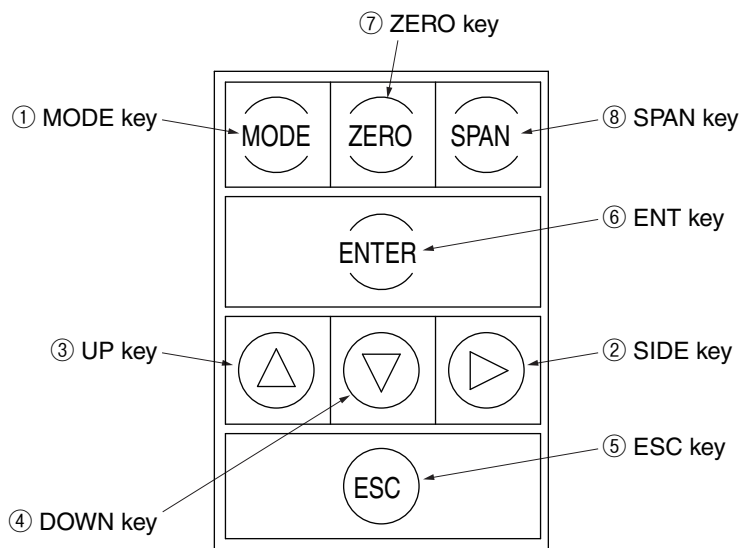

Fig. 5-1

Name	Description	Name	Description
① MODE key	Used to switch the mode.	⑤ ESC key	Used to return to the previous screen or cancel the setting midway.
② SIDE key	Used to change the selected item (by moving the cursor) and the numeral digit.	⑥ ENT key	Used for confirmation of selected items or values, and for execution of calibration.
③ UP key	Used to change the selected item (by moving the cursor) and to increase the numeral value.	⑦ ZERO key	Used for zero calibration.
④ DOWN key	Used to change the selected item (by moving the cursor) and to decrease the numeral value.	⑧ SPAN key	Used for span calibration.

5.2 Overview of display and operation panels

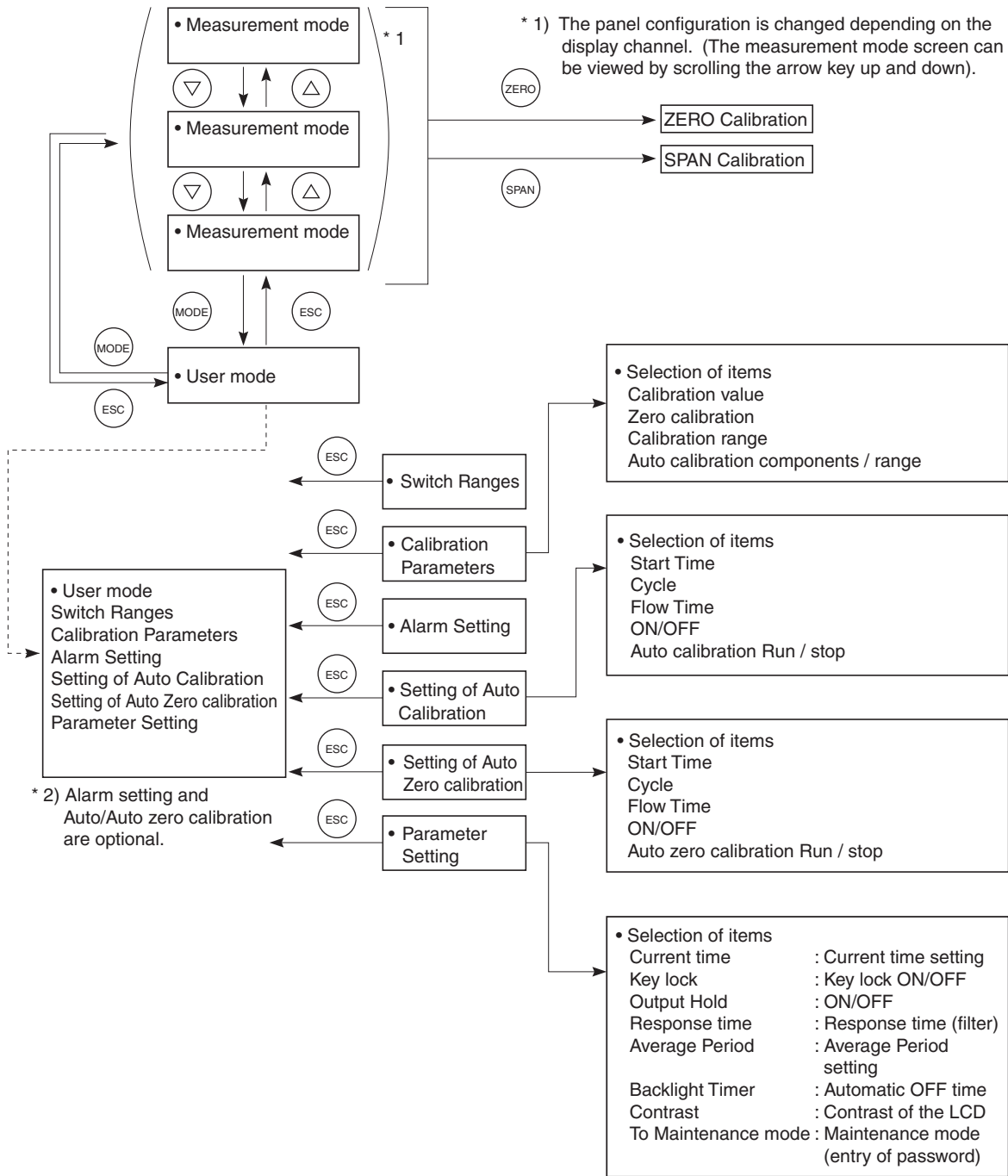

Fig. 5-2

5.3 Outline of display screen

(1) Measurement mode screen (appears when the power is turned ON)

The measurement screen depends on the number of components. The following screen configuration as shown as an example is for NO, SO₂, CO₂, CO and O₂ (output: 12 channels).

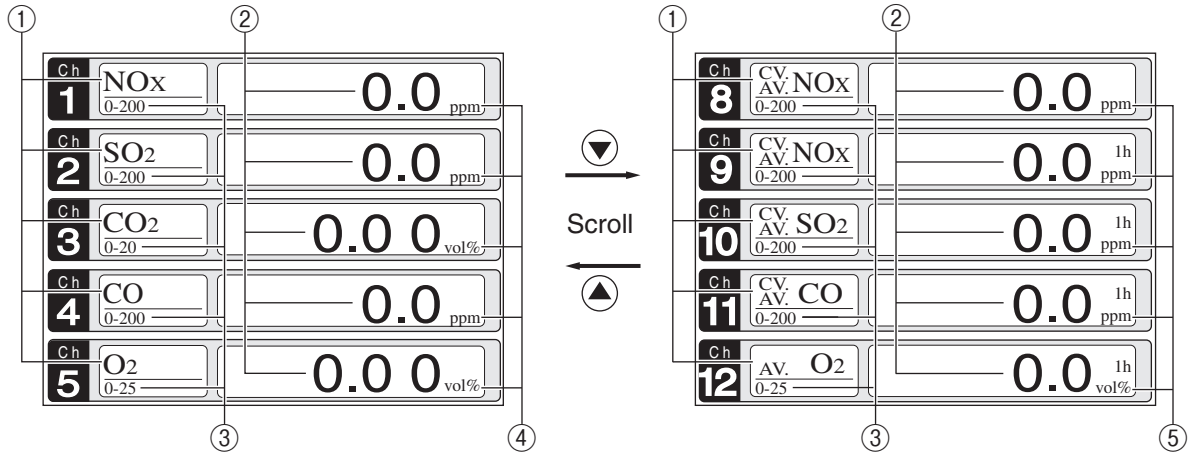

Fig. 5-3

* For outputs of more than 5 channels, scroll the or the key to view.

No.	Name	Function
①	Component display	Displays the component of instantaneous value, corrected instantaneous value, corrected average value, etc.
②	Concentration display	Displays the measured value of concentration.
③	Range display	Displays the range values.
④	Unit display	Displays the unit with ppm and vol%.
⑤	Average time display	Displays the average time.

- **Instantaneous value and concentration value:**

The concentration display of Ch (component) where sampling components such as “CO₂”, “CO” and “O₂” are displayed in the component display, indicates current concentration values of the measured components contained in gas that is now under measurement.

- **O₂ correction concentration values:**

Ch components where “cv**” is displayed as “cv CO” in the component display are calculated from the following equation, by setting sampling components, O₂ instantaneous/concentration values and O₂ correction reference value (see item 6.8).

$$\text{Correction output} = \frac{21 - O_n}{21 - O_s} \times C_s$$

On: The value of the O₂ correction reference value (Value set by application)
 Os: Oxygen concentration (%)
 Cs: Concentration of relevant measured component.
 Note that Os does not exceed the O₂ limit value set in “Other Parameter” in “6.7 Maintenance mode.”

The corrected sampling components are NO_x, SO₂ and CO only.

- **O₂ correction concentration average value:**

In the Ch (component) and O₂ average value where “^{CV}_{AV} **” is displayed as “^{CV}_{AV} CO” in the component display, a value obtained by averaging O₂ correction concentration value or O₂ average value in a fixed time is output every 30 seconds.

Averaging time can be changed between 1 to 59 minutes or 1 to 4 hours according to the average time settings (See 6.7, Parameter setting).

(The set time is displayed as “1h”, for instance, in the range display.)

* The measurement ranges of O₂ correction concentration value and O₂ correction concentration average value are the same as that of the measuring components. Also, the measurement range of O₂ average value is the same as that of O₂.

(2) Setting/selection screen

The setting/selection screen is configured as shown below:

- In the status display area, the current display item is displayed.
- In the message display area, messages associated with operation are displayed.
- In the setting item and selection item display area, items or values to be set are displayed, as required. To work on the area, move the cursor to any item by using UP, DOWN and SIDE keys.

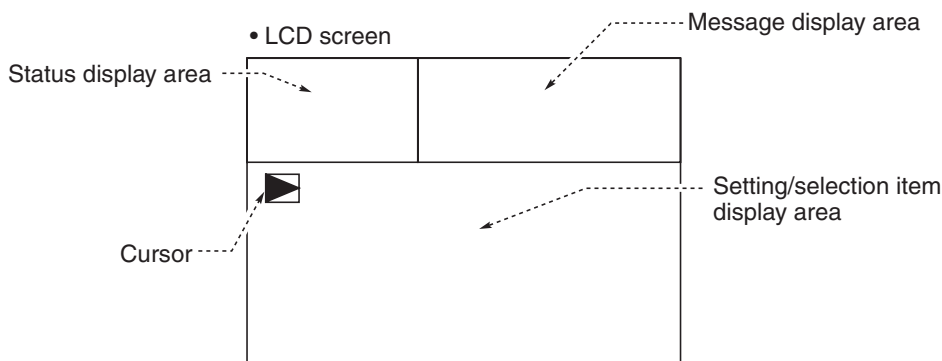

Fig. 5-4

(3) Contents of measured channel (Ch)



The following table gives measurement channels and their contents according to the symbols.

Code symbol			Display/output contents
6th digit	7th digit	21st digit	
Y	1 to 3	Y	Ch1:O ₂
P	Y	Y	Ch1:NO
A	Y	Y	Ch1:SO ₂
D	Y	Y	Ch1:CO ₂
B	Y	Y	Ch1:CO
E	Y	Y	Ch1:CH ₄
F	Y	Y	Ch1:NO, Ch2:SO ₂
G	Y	Y	Ch1:NO, Ch2:CO
J	Y	Y	Ch1:CO ₂ , Ch2:CO
K	Y	Y	Ch1:CH ₄ , Ch2:CO
L	Y	Y	Ch1:CO ₂ , Ch2:CH ₄
N	Y	Y	Ch1:NO, Ch2:SO ₂ , Ch3:CO
T	Y	Y	Ch1:CO ₂ , Ch2:CO, Ch3:CH ₄
V	Y	Y	Ch1:NO, Ch2:SO ₂ , Ch3:CO ₂ , Ch4:CO
P	1 to 3	Y	Ch1:NO, Ch2:O ₂
A	1 to 3	Y	Ch1:SO ₂ , Ch2:O ₂
D	1 to 3	Y	Ch1:CO ₂ , Ch2:O ₂
B	1 to 3	Y	Ch1:CO, Ch2:O ₂
E	1 to 3	Y	Ch1:CH ₄ , Ch2:O ₂
F	1 to 3	Y	Ch1:NO, Ch2:SO ₂ , Ch3:O ₂
G	1 to 3	Y	Ch1:NO, Ch2:CO, Ch3:O ₂
J	1 to 3	Y	Ch1:CO ₂ , Ch2:CO, Ch3:O ₂
K	1 to 3	Y	Ch1:CH ₄ , Ch2:CO, Ch3:O ₂
L	1 to 3	Y	Ch1:CO ₂ , Ch2:CH ₄ , Ch3:O ₂
N	1 to 3	Y	Ch1:NO, Ch2:SO ₂ , Ch3:CO, Ch4:O ₂
T	1 to 3	Y	Ch1:CO ₂ , Ch2:CO, Ch3:CH ₄ , Ch4:O ₂
V	1 to 3	Y	Ch1:NO, Ch2:SO ₂ , Ch3:CO ₂ , Ch4:CO, Ch5:O ₂
P	1 to 3	A *	Ch1:NO _x , Ch2:O ₂ , Ch3:corrected NO _x
A	1 to 3	A *	Ch1:SO ₂ , Ch2:O ₂ , Ch3:corrected SO ₂
B	1 to 3	A *	Ch1:CO, Ch2:O ₂ , Ch3:corrected CO
F	1 to 3	A *	Ch1:NO _x , Ch2:SO ₂ , Ch3:O ₂ , Ch4:corrected NO _x , Ch5:corrected SO ₂
G	1 to 3	A *	Ch1:NO _x , Ch2:CO, Ch3:O ₂ , Ch4:corrected NO _x , Ch5:corrected CO
J	1 to 3	A *	Ch1:CO ₂ , Ch2:CO, Ch3:O ₂ , Ch4:corrected CO
N	1 to 3	A *	Ch1:NO _x , Ch2:SO ₂ , Ch3:CO, Ch4:O ₂ , Ch5:corrected NO _x , Ch6:corrected SO ₂ , Ch7:corrected CO
V	1 to 3	A *	Ch1:NO _x , Ch2:SO ₂ , Ch3:CO ₂ , Ch4:CO, Ch5:O ₂ , Ch6:corrected NO _x , Ch7:corrected SO ₂ , Ch8:corrected CO
P	1 to 3	C *	Ch1:NO _x , Ch2:O ₂ , Ch3:corrected NO _x , Ch4:corrected NO _x average
A	1 to 3	C *	Ch1:SO ₂ , Ch2:O ₂ , Ch3:corrected SO ₂ , Ch4:corrected SO ₂ average
B	1 to 3	C *	Ch1:CO, Ch2:O ₂ , Ch3:corrected CO, Ch4:corrected CO average
F	1 to 3	C *	Ch1:NO _x , Ch2:SO ₂ , Ch3:O ₂ , Ch4:corrected NO _x , Ch5:corrected SO ₂ , Ch6:corrected NO _x average, Ch7:corrected SO ₂ average
G	1 to 3	C *	Ch1:NO _x , Ch2:CO, Ch3:O ₂ , Ch4:corrected NO _x , Ch5:corrected CO, Ch6:corrected NO _x average, Ch7:corrected CO average
J	1 to 3	C *	Ch1:CO ₂ , Ch2:CO, Ch3:O ₂ , Ch4:corrected CO, Ch5:corrected CO average
N	1 to 3	C *	Ch1:NO _x , Ch2:SO ₂ , Ch3:CO, Ch4:O ₂ , Ch5:corrected NO _x , Ch6:corrected SO ₂ , Ch7:corrected CO, Ch8:corrected NO _x average, Ch9:corrected SO ₂ average, Ch10:corrected CO average
V	1 to 3	C *	Ch1:NO _x , Ch2:SO ₂ , Ch3:CO ₂ , Ch4:CO, Ch5:O ₂ , Ch6:corrected NO _x , Ch7:corrected SO ₂ , Ch8:corrected CO, Ch9:corrected NO _x average, Ch10:corrected SO ₂ average, Ch11:corrected CO average

* When the 21st digit code is A or C, the component of the NO analyzer is displayed as NO_x.

5.4 Basic operation

• Measurement mode

The measurement mode can be displayed up to 5 channels in a single screen. If 5 channels or more are to be displayed in a single screen, press the  or the  key to scroll the channel one by one.

Ch 1	NO _x 0-200	0.0 ppm
Ch 2	SO ₂ 0-200	0.0 ppm
Ch 3	CO ₂ 0-10	0.00 vol%
Ch 4	CO 0-200	0.0 ppm
Ch 5	O ₂ 0-25	0.00 vol%



Ch 5	O ₂ 0-25	0.00 vol%
Ch 6	cv. NO _x 0-200	0.0 ppm
Ch 7	cv. SO ₂ 0-10	0.0 ppm
Ch 8	CV. AV. CO 0-200	0.0 ppm
Ch 9	CV. AV. NO _x 0-200	0.0 ppm



Ch 8	CV. AV. CO 0-200	0.0 ppm
Ch 9	CV. AV. NO _x 0-200	0.0 ppm
Ch 10	CV. AV. SO ₂ 0-200	0.0 ppm
Ch 11	CV. AV. CO 0-200	0.0 ppm
Ch 12	AV. O ₂ 0-25	0.00 vol%

ZERO

⇒ Zero calibration
See 6.9.1.

⇒ Span calibration
See 6.9.2.



SPAN

ESC

MODE

• User mode displays;

- Switch Ranges
- Calibration Parameters
- Alarm Setting
- Setting of Auto Calibration
- Setting of Auto Zero Calibration
- Parameter Setting.

Press the  or the  key and move the cursor preceding the each display item.

Each display item is displayed by pressing the  key.

User Mode	Select an item with UP/DOWN and ENT Back with ESC
<input checked="" type="checkbox"/> Switch Ranges Calibration Parameters Alarm Setting Setting of Auto Calibration Setting of Auto Zero Calibration Parameter Setting	



Measurement Mode







For the setting contents, refer to “Chapter 6. Setting and calibration”.



6. SETTING AND CALIBRATION

6.1 Switch of range

6.1.1 Setting of range switch mode

Set the range switch mode as follows.

- (1) Press the  key in measurement mode to display the User mode screen.
- (2) Move the cursor to “Switch Ranges” and press the  key.
- (3) In the “Channel Selection” screen that appears, move the  cursor by pressing the  or the  key, and select Ch (component).
- (4) Then press the  key.

- (5) Selected range switch mode is highlighted.
Press the  or the  key to select a desired switch mode.

Description of setting







- MR: Select a desired range on this screen.
 RR: Select a desired range according to the remote range switch contact input.
 AR: Automatically switched from Range 1 to Range 2 when the measured concentration exceeds 90% of Range 1.
 Automatically switched from Range 2 to Range 1 when the measured concentration becomes smaller than 80% of Range 1.
- * Operation set for each Ch only can be performed.





- (6) Then press the  key to confirm the selection.
If “MR” is selected, the cursor moves to “Range Switch.”







↓ 

User Mode	Select an item with UP/DOWN and ENT Back with ESC
 Switch Ranges	Calibration Parameters Alarm Setting Setting of Auto Calibration Setting of Auto Zero Calibration Parameter Setting

↓ 

Switch Range	Select Ch No. with UP / DOWN and ENT Back with ESC
 Ch1 NO _x MR	 Range1 0-200.0 ppm Range2 0-2000 ppm
Ch2 SO ₂ AR	 Range1 0-200.0 ppm Range2 0-2000 ppm
Ch3 CO ₂ RR	 Range1 0-10.00 vol% Range2 0-20.00 vol%
Ch4 CO MR	 Range1 0-200.0 ppm Range2 0-1000 ppm
Ch5 O ₂ MR	 Range1 0-10.00 vol% Range2 0-25.00 vol%

↓   () 

Switch Range	Select method of Switch ranges with UP / DOWN and ENT Back with ESC
Ch1 NO _x 	 Range1 0-200.0 ppm Range2 0-2000 ppm
Ch2 SO ₂ AR	 Range1 0-200.0 ppm Range2 0-2000 ppm
Ch3 CO ₂ RR	 Range1 0-10.00 vol% Range2 0-20.00 vol%
Ch4 CO MR	 Range1 0-200.0 ppm Range2 0-1000 ppm
Ch5 O ₂ MR	 Range1 0-10.00 vol% Range2 0-25.00 vol%

↓ 

Range switch or previous screen
--





6.1.2 Manual range switch

The range of the measured component can be switched manually as follows.

- (1) Select “MR” as range switch mode, and then press the  key.

Switch Range		Select method of Switch ranges with UP / DOWN and ENT Back with ESC
Ch1 NO _x		▶ Range1 0-200.0 ppm Range2 0-2000 ppm
Ch2 SO ₂	AR	▶ Range1 0-200.0 ppm Range2 0-2000 ppm
Ch3 CO ₂	RR	▶ Range1 0-10.00 vol% Range2 0-20.00 vol%
Ch4 CO	MR	▶ Range1 0-200.0 ppm Range2 0-1000 ppm
Ch5 O ₂	MR	▶ Range1 0-10.00 vol% Range2 0-25.00 vol%



- (2) Move the highlight of the cursor to range selection, and then select a desired range by pressing the  or the  key. (The  mark indicates the currently selected range.)
- (3) Then press the  key, and the measurement is carried out in the selected range.

Switch Range		Select range with UP/DOWN and ENT Back with ESC
Ch1 NO _x	MR	▣ Range1 0-200.0 ppm Range2 0-2000 ppm
Ch2 SO ₂	AR	▶ Range1 0-200.0 ppm Range2 0-2000 ppm
Ch3 CO ₂	RR	▶ Range1 0-10.00 vol% Range2 0-20.00 vol%
Ch4 CO	MR	▶ Range1 0-200.0 ppm Range2 0-1000 ppm
Ch5 O ₂	MR	▶ Range1 0-10.00 vol% Range2 0-25.00 vol%



Note) If “RR” or “AR” is selected as range switch mode, this operation cannot be performed.

The range for O₂ correction value, O₂ correction average value, and O₂ average value is automatically switched if corresponding instantaneous value range is switched. (Same as for “RR” or “AR”).

End of Range Switch

To close the setting

Press the  key to end the setting of range switch mode or range switch operation or stop the operation in the middle. The setting operation is made invalid and the previous screen appears.

Range identification contact operation

The range identification contact output corresponding to each Ch (component) is conductive when Range 1 is selected, and open when Range 2 is selected, which is applicable to any of the range switch mode selected.

Note that even if the range is switched during the hold of measurement value by remote hold contact input or the hold of measurement value at the time of calibration, the range identification contact output maintains the contact state immediately before the hold. After the hold is canceled, the contact state of the current range is resumed.







6.2 Calibration setting

This mode is used to set calibration concentration and actions. The calibration setting involves calibration concentration, zero calibration, calibration range and auto calibration component/range.

In the “Calibration Parameters” screen that appears, the data shown at right is illustrated.

6.2.1 Setting of calibration concentration

It allows you to set concentrations of the standard gas (zero and span) of each Ch used for calibration.

- (1) Select < User mode > → < Calibration parameters > → < Calibration value >. “Caribration Value Settings” screen appears as shown at right.
- (2) Select the Ch you want to change by pressing the  or the  key. Press the  key and cursor moves preceding the value.
- (3) Select the concentration item you want to make the setting by pressing the ,  key or the  key (movable within the selected Ch). Then press the  key, and the selected value is highlighted.

Cal. Parameters	Select an item with UP/DOWN and ENT Back with ESC
 Calibration Valve About ZERO Calibration About Calibration Range Auto Calibration Components / Range	



Cal. Settings	Select setting value		
Cal. Value			
CH	RANGE	ZERO	SPAN
Ch1	0-200.0ppm	+0000.0	0200.0
NOx	0-2000ppm	+00000	02000
Ch2	0-200.0ppm	+0000.0	0200.0
SO ₂	0-2000ppm	+00000	02000
Ch3	0-10.00vol%	+000.00	010.00
CO ₂	0-20.00vol%	+000.00	020.00
Ch4	0-200.0ppm	+0000.0	0200.0
CO	0-1000ppm	+00000	01000
Ch5	0-10.00vol%	21.00	01.00
O ₂	0-25.00vol%	21.00	01.00



(4) Then, enter calibration gas concentration values (zero and span). For value entry, press the \blacktriangle or the \blacktriangledown key, and a 1-digit value increases or decreases. By pressing the \blacktriangleright key, the digit moves.

After setting, save the entry by pressing the ENT key. The saved value becomes valid from the next calibration process.

Note) Enter settings that correspond to each range. If zirconia type is used as O₂ sensor, select 21.00 for the field of Zero (when air is used), and select the concentration listed on the cylinder if the air contained in a cylinder is used.

\blacktriangledown \blacktriangledown (\blacktriangle) ENT

Cursor for setting value

Cal. Settings		Set calibration value	
Cal. Value			
CH	RANGE	ZERO	SPAN
Ch1	0-200.0ppm	+0000.0	000.0
NO _x	0-2000ppm	+00000	02000
Ch2	0-200.0ppm	+0000.0	0200.0
SO ₂	0-2000ppm	+00000	02000
Ch3	0-10.00vol%	+000.00	010.00
CO ₂	0-20.00vol%	+000.00	020.00
Ch4	0-200.0ppm	+0000.0	0200.0
CO	0-1000ppm	+00000	01000
Ch5	0-10.00vol%	21.00	01.00
O ₂	0-25.00vol%	21.00	01.00

\blacktriangledown \blacktriangledown (\blacktriangle) \blacktriangleright ENT

**End of Calibration
Concentration Setting**

To close the setting

To close the calibration concentration value setting process or cancel this mode midway, press the ESC key. A previous screen will return.

Setting range of values

NO _x , SO ₂ , CO ₂ , CO, CH ₄ , external O ₂ measurement and built-in O ₂ sensor	Span gas: 1 to 105% of full scale (Full scale (FS) is the same as each range value.)
External Zirconia O ₂ measurement	Zero gas: 5 to 25 vol% / Span gas: 0.01 to 5 vol%

The setting cannot be performed beyond the range.

6.2.2 Setting of manual zero calibration

When zero calibration is made manually, set either all measurement components should be calibrated simultaneously or each component should be calibrated while selecting one by one.

- (1) Select < User mode > → < Calibration parameters > → < Zero calibration >. “Zero Calibration” screen appears as shown at right.
- (2) Select the Ch you want to change by pressing the ▲ or the ▼ key. Press the ENT key and the setting content is highlighted.
- (3) Select “at once” or “each” by pressing the ▲ or ▼ key.
 - When selecting “at once”, the Ch (components) to be set can be zero-calibrated at the same time.
 - When selecting “each”, either of the Ch (component) as shown at right is selected and zero-calibrated.
 Press the ENT key after the setting, and the specified calibration is performed.

Cal. Settings ZERO Cal.		Set each or both Ch at ZERO Calibration
Ch1 NO _x	Range1 0-200.0ppm Range2 0-2000 ppm	at once
Ch2 SO ₂	Range1 0-200.0ppm Range2 0-2000 ppm	at once
Ch3 CO ₂	Range1 0-10.00vol% Range2 0-20.00vol%	at once
Ch4 CO	Range1 0-200.0ppm Range2 0-1000 ppm	at once
Ch5 O ₂	Range1 0-10.00vol% Range2 0-25.00vol%	each



**End of
Manual Zero Calibration Setting**

To close the setting

To close the manual zero calibration setting or to cancel this mode midway, press the ESC key. A previous screen will return.

Example

Whether “each” or “at once” can be determined for each Ch (component).

•Setting “each”

Select the Ch (component) on the manual zero calibration screen and then perform the zero calibration.

•Setting “at once”

At a manual zero calibration, Ch (components) for which “at once” was selected can simultaneously be zero-calibrated.

Manual Calibration screen

- When setting all components to “each”:

ZERO Cal.	ENT : Go on Calibration of selected Ch		
	ESC : Not calibration		
Ch1 NO _x	▶Range1 0-200.0ppm Range2 0-2000 ppm	▣	-2.1
Ch2 SO ₂	▶Range1 0-200.0ppm Range2 0-2000 ppm		-0.5
Ch3 CO ₂	▶Range1 0-10.00vol% Range2 0-20.00vol%		0.00
Ch4 CO	▶Range1 0-200.0ppm Range2 0-1000 ppm		0.0
Ch5 O ₂	▶Range1 0-10.00vol% Range2 0-25.00vol%		21.00

A single cursor will appear.

- When setting all components to “at once”:

ZERO Cal.	ENT : Go on Calibration of selected Ch		
	ESC : Not calibration		
Ch1 NO _x	▶Range1 0-200.0ppm Range2 0-2000 ppm	▣	0.0
Ch2 SO ₂	▶Range1 0-200.0ppm Range2 0-2000 ppm	▣	0.3
Ch3 CO ₂	▶Range1 0-10.00vol% Range2 0-20.00vol%	▣	0.00
Ch4 CO	▶Range1 0-200.0ppm Range2 0-1000 ppm	▣	-0.1
Ch5 O ₂	▶Range1 0-10.00vol% Range2 0-25.00vol%	▣	21.00

Cursors will appear at all components where “at once” is set.

6.2.3 Setting of calibration range

This mode is used to set if the range of each Ch (component) at the zero or span calibration (manual or auto calibration) should be calibrated with a single range or 2 ranges.

- (1) Select < User mode > → < Calibration parameters > → < Calibration range >. “Calibration Range” screen appears as shown at right.
 - (2) Select the Ch you want to change by pressing the or the key. Press the key and the setting contents is highlighted.
 - (3) Select “both” or “current” by pressing the or the key.
 - If “both” is selected, zero or span calibration is performed with Range 1 and Range 2 of the selected Ch interlocked when calibration is performed.
 - If “current” is selected, zero or span calibration is performed only for the range displayed when calibration is performed.
- Press the key after the selection, and the specified calibration is performed.

Cal. Settings		Set calibration range
Cal. Range		current or both range
Ch1 NO _x	Range1 0-200.0ppm Range2 0-2000 ppm	both
Ch2 SO ₂	Range1 0-200.0ppm Range2 0-2000 ppm	current
Ch3 CO ₂	Range1 0-10.00vol% Range2 0-20.00vol%	current
Ch4 CO	Range1 0-200.0ppm Range2 0-1000 ppm	both
Ch5 O ₂	Range1 0-10.00vol% Range2 0-25.00vol%	current



End of Calibration Range Setting

To close “Setting of Calibration Range”

To close “Setting of Calibration Range” or to cancel this mode midway, press the key. A previous screen will return.

Example

Ch1 NO _x	Range 1: 0 to 200 ppm Range 2: 0 to 2000 ppm	both
Ch2 SO ₂	Range 1: 0 to 200 ppm Range 2: 0 to 2000 ppm	current

Ch1: Range 1 and Range 2 are calibrated together.
Ch2: Only currently displayed range is calibrated.

Note

To perform calibration for “both,” set the same calibration gas concentration for both ranges.

Manual Calibration screen

When setting NO_x and CO to “both”

ZERO Cal.		ENT : Go on calibration of selected Ch ESC : Not calibration	
Ch1 NO _x	▶ Range1 0-200.0ppm Range2 0-2000 ppm	◀▶	-0.6
Ch2 SO ₂	▶ Range1 0-200.0ppm Range2 0-2000 ppm	◀▶	0.4
Ch3 CO ₂	▶ Range1 0-10.00vol% Range2 0-20.00vol%	◀▶	0.00
Ch4 CO	▶ Range1 0-200.0ppm Range2 0-1000 ppm	◀▶	-0.1
Ch5 O ₂	▶ Range1 0-10.00vol% Range2 0-25.00vol%	◀▶	21.00

Two cursors will appear in both ranges (Ch1 and Ch4).

6.2.4 Setting of auto calibration component/range

Select the Ch (component) and the range with which auto calibration is to be performed. The Ch for which “AR” has been selected as range switch mode is calibrated in the range set here even when manual calibration is performed.

- (1) Select < User mode > → < Calibration parameters > → < Auto calibration component/range >. “Auto Calibration Component Range” setting screen appears as shown at right.
- (2) Select the Ch you want to change by pressing the ▲ or the ▼ key. Press the ENT key and the selected cursor is highlighted.
- (3) Select the range to be calibrated mainly by pressing the ▲ or the ▼ key.
- (4) Then press the ENT key, and calibration is performed in the selected range when auto calibration or auto zero calibration is performed.

Cal. Settings Auto Cal.		Select a range for auto calibration	
Ch1 NOx	▶ Range1 0-200.0ppm Range2 0-2000 ppm		enable
Ch2 SO2	▶ Range1 0-200.0ppm Range2 0-2000 ppm		enable
Ch3 CO2	▶ Range1 0-10.00vol% Range2 0-20.00vol%		enable
Ch4 CO	▶ Range1 0-200.0ppm Range2 0-1000 ppm		enable
Ch5 O2	▶ Range1 0-10.00vol% ▶ Range2 0-25.00vol%		enable

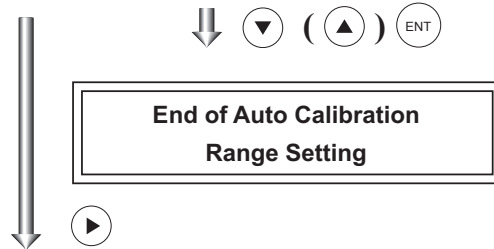

Cal. Settings Auto Cal.		Set enable or disable for auto calibration	
▶ Ch1 NOx	Range1 0-200.0ppm Range2 0-2000 ppm		enable
Ch2 SO2	Range1 0-200.0ppm Range2 0-2000 ppm		enable
Ch3 CO2	Range1 0-10.00vol% Range2 0-20.00vol%		enable
Ch4 CO	Range1 0-200.0ppm Range2 0-1000 ppm		enable
Ch5 O2	Range1 0-10.00vol% Range2 0-25.00vol%		enable

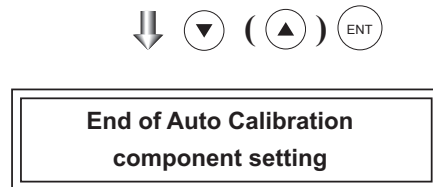

“Auto Calibration Component/range” setting

Auto calibration and the manual calibration of the component with which “AR” has been selected as range switch mode are performed in the range selected here. In this case, once the calibration is started, the range is automatically switched, and on completion of the calibration, the original range is resumed.

The range identification contact is interlocked with the range after the switch. However, if the hold setting is set to “ON,” the contact status before calibration is maintained.

- (5) Press the ▶ key in the state described in (3), and the highlight is switched between “enable” and “disable” auto calibration.
- (6) Select “enable” of “disable” by pressing the ▲ or the ▼ key.
- (7) Then press the ENT key.

To close the setting

Press the **ESC** key to exit automatic calibration component/range setting, and the previous screen appears.

Operation by setting

Auto calibration is performed under the following rules.

1. Zero calibration is performed at the same time, for the Ch (component) with which “enable” is selected at the time of auto calibration and auto zero calibration.
2. Span calibration is performed in the order from smallest Ch No., for the Ch (component) with which “enable” is selected at the time of auto calibration.

Note

ZERO calibration on auto calibration and auto zero calibration of the component with which “enable” is selected are performed in batch irrespective of the description in “6.2.2 Setting of manual zero calibration.”

6.3 Alarm setting

6.3.1 Setting of alarm values

The High/Low limit alarm output setting for the measured concentration setting can be made. Arbitrary 5 alarm contact outputs can be used.

To change alarm setting, set the alarm ON/OFF setting to OFF, and then change the value.

- (1) Enter the "Setting of Alarm No." screen from the user mode, and the display shown at right appears. Point the cursor to the Alarm No. or hysteresis you want to set by pressing \blacktriangle or the \blacktriangledown key. Press the ENT key.

Alarm Setting	Select Alarm No. or Hysteresis setting
\blacktriangleright Alarm-1 Alarm-2 Alarm-3 Alarm-4 Alarm-5	
Hysteresis	00 %FS



- (2) Select the alarm 1 to 6 to display the screen shown at right. Operate the \blacktriangle or the \blacktriangledown key until the cursor is aligned with a desired item and press the ENT key.

Alarm Setting Alarm-1	Select an item with UP/DOWN and ENT Back with ESC
\blacktriangleright Channel	Ch 1
H-Limit Range 1	200.0 ppm
Range 2	2000 ppm
L-Limit Range 1	000.0 ppm
Range 2	0000 ppm
Kind of Alarm	High
ON / OFF	OFF



Note

Set the values so that H-limit value > L-limit value and that (H-limit value - L-limit value) > hysteresis.

When "0" is set, the alarm operation is not performed.

- (3) After setting, the alarm setting is now completed by pressing the ENT key.

To close the "Alarm Setting"

To close the "Alarm Setting" or to cancel this mode midway, press the ESC key. A previous screen will return.

Setting range

0% to 100% FS (Settable in each range).

Cursor for setting value

Alarm Setting Alarm-1	Select an item with UP/DOWN and ENT Back with ESC
\blacktriangleright Channel	Ch 1
H-Limit Range 1	\blacksquare 00.0 ppm
Range 2	2000 ppm
L-Limit Range 1	000.0 ppm
Range 2	0000 ppm
Kind of Alarm	High
ON / OFF	OFF



End of Alarm Setting

Description of setting items

The alarm contact assigned the same number as the alarm is operated accordingly.

Channel: Channel setting targeted for issuance of alarm.
 One Ch No. can be selected for multiple alarms.

H-Limit value: Sets the high limit value (concentration) of alarm.

L-Limit value: Sets the low limit value (concentration) of alarm.

Kind of Alarm: Selects one of High limit alarm, Low limit alarm, and High limit or Low limit alarm, HH limit alarm, and LL limit alarm.
 High, HH Alarm contact closes when above H-limit alarm.
 Low, LL Alarm contact closes when below L-limit alarm.
 High or Low... Alarm contact closes when above H-limit value or below lower limit value.

ON/OFF: Enables the alarm function if set at ON, or disables it if set at OFF.

* The H-limit value cannot be set below the L-limit value, and the L-limit value cannot be set above the H-limit value.

If it is desired to set the H-limit value below the L-limit value already stored in the memory, reduce the L-limit value beforehand, and vice versa.

Typical on-screen display when an alarm occurs

When an H-limit alarm occurs, the “H-alarm” message comes on in the field of relevant Ch (component). (“L-alarm” for L-limit alarm, “HH-alarm” for HH limit alarm, and “LL-alarm” for LL limit alarm)

Ch	H-alarm	
2	SO ₂ (0-200)	0.0 ppm
3	CO ₂ (0-10)	0.003 vol% _s
4	CO (0-200)	0.0 ppm
5	O ₂ (0-25)	21.00 vol% _s

Note

After turning on power, the alarm judgment is inactive for 10 minutes.

6.3.2 Hysteresis setting

To prevent chattering of an alarm output near the alarm setting values, set the value of hysteresis.

(1) In the “Alarm Setting” screen that appears, point the cursor to “Hysteresis” by pressing the \blacktriangle or the \blacktriangledown key. Press the ENT key to display the screen shown at right.

(2) Then, enter hysteresis values.

For the value entry, 1-digit value is increased or decreased by pressing the \blacktriangle or the \blacktriangledown key, and pressing the \blacktriangleright key moves the digit. After setting, press the ENT key to make the “Hysteresis” valid.

Alarm Setting	Set Hysteresis 0 to 20%FS available
Alarm-1 Alarm-2 Alarm-3 Alarm-4 Alarm-5 Alarm-6	
Hysteresis	00 %FS



End of Hysteresis Setting

To close "Hysteresis Setting"
 To close the “Hysteresis Setting” or cancel the mode midway, press the ESC key. A previous screen will return.

Setting range
 0 to 20% of full scale
 [% full scale (FS)] represents the percentage with the width of the range of each component regarded as 100%.

Note
 The hysteresis is common to all alarms (components).

Hysteresis (In case of upper limit alarm)

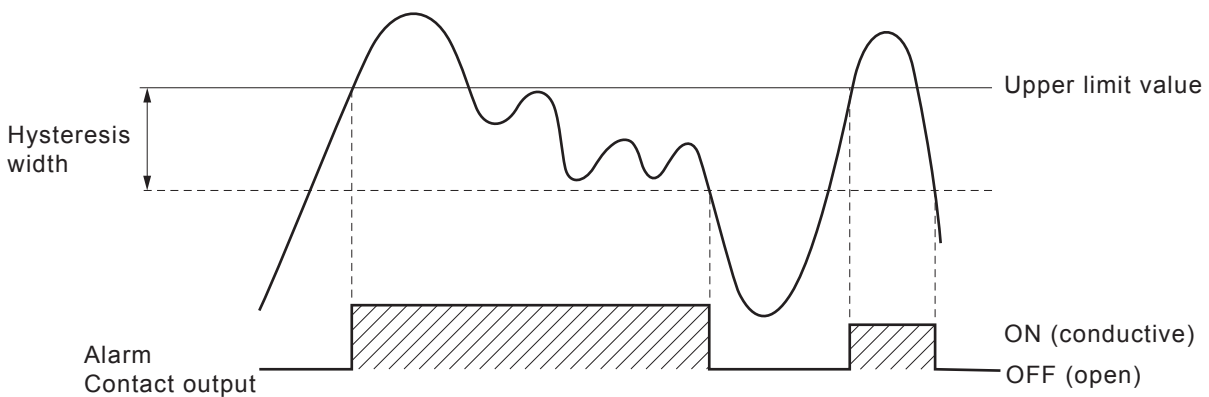

An alarm output is turned ON if measurement value exceeds the upper limit value as shown below. Once the alarm output has been turned ON, it is not turned OFF as long as the indication does not fall below the hysteresis width from the upper limit value.







6.4 Setting of auto calibration

6.4.1 Auto calibration

Auto calibration is automatically carried out at the time when zero span calibration are set. Before changing the setting of auto calibration, set the ON/OFF to OFF.

- (1) Enter the "Setting of Auto Calibration" screen from the user mode, and the display shown at right appears. Operate the  or the  key until the cursor is aligned with a desired item and press the  key.

- (2) In the "Setting of Auto Calibration" screen that appears, perform the value entry or the setting. For the value entry or setting change, use the  or the  key, and the  key to move the cursor to the right.

After setting, press the  key, and auto calibration is carried out by the entered setting value.

Description of setting items

- Start Time : Setting at the first calibration (day of the week, hour, minute)
- Cycle : A period between the start time of one calibration and another (unit : hour/day)
- Flow Time : The time required for replacement by calibration gas
Time required for replacement of sample gas after the calibration is completed (Set by calibration gas. See the next page.)
- ON/OFF : ON/OFF of auto calibration



To close "Setting of Auto calibration"

To close the "Setting of Auto calibration" or cancel this mode midway, press the  key.
A previous screen will return.

Set Auto Cal.	Select setting item
	Start Time SUN 12:00 Cycle 07 day Flow Time ON / OFF OFF
	Time : MON 12:34
Auto Calibration Run	











Set Auto Cal.	Set Start Time
	Start Time SUN 12:00 Cycle 07 day Flow Time ON / OFF OFF
	Time : MON 12:34
Auto Calibration Run	

Press the  or the  key, and date and time are displayed alternately.



End of Auto Calibration Setting

<Gas flow time> setting

- (1) Press the  key in a state where the cursor is placed preceding “Flow Time,” and the flow time setting screen appears.
- (2) Move the cursor to the gas you want to change by pressing the  or the  key, and then press the  key.
- (3) The highlighted value can be changed. Change the value by pressing the  or the  key, and then move the cursor to the right by pressing the  key.
- (4) After changing the value, press the  key.
- (5) Press the  key to return to the auto-matic calibration setting screen.

Set Auto Cal.	Set flow time of calibration gas 60 to 900 sec
Zero	 50 sec.
Ch1 Span	350 sec.
Ch2 Span	350 sec.
Ch3 Span	350 sec.
Ch4 Span	300 sec.
Ch5 Span	300 sec.
Ex. time	300 sec.



Note) Only the Chs used are displayed on this screen. The Ex. time is the output signal hold extension time after the completion of calibration. It is valid only when the hold setting is set to “ON.” The Ex. time set here is also the hold extension time at the time of manual calibration.

Auto calibration status contact output is closed during auto calibration (NO side), and is open in other cases.

Example

Start Time	SUN	12:00
Cycle	1	day
Flow Time	Zero	350 sec
	Ch1 Span	350 sec
	Ch2 Span	350 sec
	Ch3 Span	350 sec
	Ch4 Span	300 sec
	Ch5 Span	300 sec
	EX. time	300 sec
ON/OFF	ON	

In case where auto calibration is carried out at the above setting.

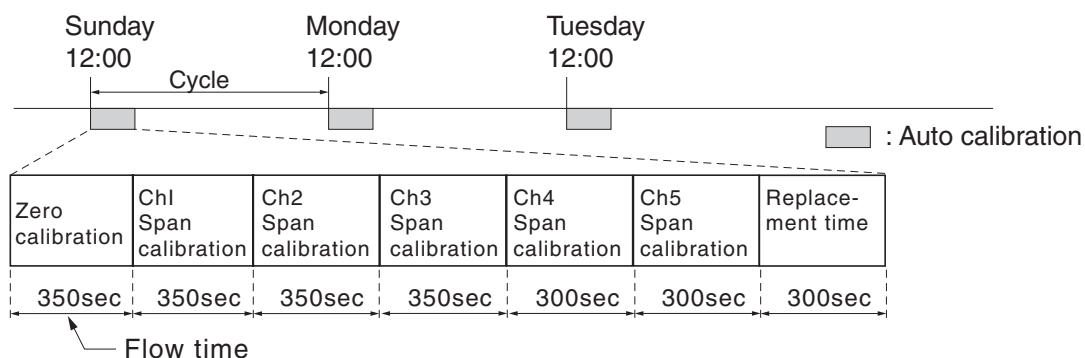

(An example of “Ch1: through Ch5: enable”, as given in Item 6.2.4 “Auto Calibration Components/range”)

Setting range

Cycle : 1 to 99 hours or 1 to 40 days (initial value 7 days)
 Flow time : 60 to 900 sec (initial value 300 sec)

Caution

- When an auto calibration starts, the measurement screen appears automatically.
- Any operation other than “Stop Auto Calibration” (see Item 6.4.2) is not permitted during auto calibration. “Stop Auto Calibration” cannot be performed with the key lock to ON. To cancel auto calibration forcedly, set the key lock to OFF and then execute “Stop Auto Calibration”.
- Turn on the power again after it is turned off (including the case of power failure) at the time set as the next start time in auto calibration, and then repeat it in the set cycle.

Remote start



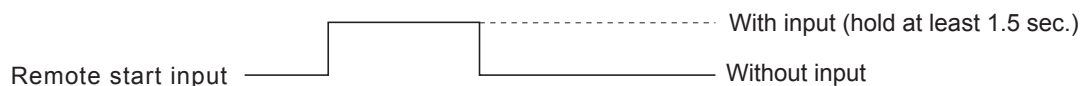

Whether the auto calibration is set at ON or OFF, an auto calibration is available by remote start input.



6.4.2 Forced run/stop of auto calibration

Auto calibration can be performed just once or forcibly stopped while the calibration is performed.





6.4.2.1 Execution of auto calibration (only once)

- (1) In the “Setting of Auto Calibration” screen that appears, point the cursor to “Auto Calibration Run” by pressing the  or the  key. Press the  key.
- (2) “Run” is highlighted, displaying a message to confirm the execution of auto calibration. Press the  key to execute the auto calibration, and press the  key to cancel.

Set Auto Cal.	Auto Cal. Run ENT : Run / Stop ESC : Cancel
Start Time	SUN 12:00
Cycle	07 day
Flow Time	
ON / OFF	OFF
Time : MON 12:34	
Auto Calibration Run	

6.4.2.2 Forced stop of auto calibration

This mode is used to stop the auto calibration forcibly.

- (1) In the “Setting of Auto Calibration” screen that appears, point the cursor to “Auto Calibration Stop” by pressing the  or the  key. Press the  key. (“Auto Calibration Stop” appears when the screen is selected while auto calibration is performed.)
- (2) “Stop” is highlighted, displaying a message to confirm the stop of auto calibration. Press the  key to stop the auto calibration, and press the  key to cancel (not stopped).

Set Auto Cal.	Auto Cal. Stop ENT : Run / Stop ESC : Cancel
Start Time	SUN 12:00
Cycle	07 day
Flow Time	300 sec
ON / OFF	OFF
Time : MON 12:34	
Auto Calibration Stop	

“Auto Calibration” screen

Example

In case where setting the auto calibration components (see Item 6.2.4) to “Ch1: enable” and “Ch2: enable”

- Zero calibration

A message, “Zero cal.” blinks at Ch1 and Ch2.

Ch 1	ZERO cal.	0.5 ppm
Ch 2	ZERO cal.	0.3 ppm
Ch 3	CO ₂ 0-10	0.000 vol%
Ch 4	CO 0-200	0.0 ppm
Ch 5	O ₂ 0-25	21.02 vol%

- Ch1 span calibration

A message, “Span cal.” blinks at Ch1.

Ch 1	SPAN cal.	90.8 ppm
Ch 2	SO ₂ 0-200	0.0 ppm
Ch 3	CO ₂ 0-10	0.00 vol%
Ch 4	CO 0-200	0.0 ppm
Ch 5	O ₂ 0-25	0.00 vol%

- Ch2 span calibration

A message, “Span cal.” blinks at Ch2.

Ch 1	NO _x 0-200	0.0 ppm
Ch 2	SPAN cal.	95.0 ppm
Ch 3	CO ₂ 0-10	0.00 vol%
Ch 4	CO 0-200	0.0 ppm
Ch 5	O ₂ 0-25	0.00 vol%

Caution

During auto calibration, any key operation is not permitted other than operations such as key lock ON/OFF and “Auto Calibration Stop.”

When the key lock is set at ON, even the “Auto Calibration Stop” cannot be used.







To stop “Auto Calibration” forcibly, set the key lock to OFF and then execute “Auto Calibration Stop.”

6.5 Setting of auto zero calibration

6.5.1 Auto zero calibration

Auto zero calibration is automatically carried out at the time when zero calibration is set. Components for which a calibration is to be made are determined by setting of auto calibration component in Item 6.2.4.

Before changing the setting of auto zero calibration, set the ON/OFF to OFF.



- (1) Enter the "Setting of Auto Zero Calibration" screen from the user mode, and the display shown at right appears. Operate the  or the  key until the cursor is aligned with a desired item and press the  key.
- (2) In the "Setting of Auto Zero Calibration" screen that appears, perform the value entry or the setting. For the value entry or setting change, use the  or the  key and the  key to move the cursor to the right.

Set Auto Zero Cal.	Select setting item
 Start Time	SUN 12:00
Cycle	07 day
Flow Time	300 sec.
ON / OFF	OFF
Time : MON 12:34	
Auto Zero Calibration Run	



After setting, press the  key, and auto zero calibration is carried out by the entered setting value.

Set Auto Zero Cal.	Set Start Time
 Start Time	SUN 12:00
Cycle	07 day
Flow Time	300 sec.
ON / OFF	OFF
Time : MON 12:34	
Auto Zero Calibration Run	

Press the  or the  key, and date and time are displayed alternately.



End of Auto Zero Calibration Setting

Description of setting items

- Start Time : Setting at the first calibration (day of the week, hour, minute)
- Cycle : A period between the start time of one calibration and another (unit : hour/day)
- Flow Time : The time required for the calibration gas to be replaced in the cell
- ON/OFF : ON/OFF of auto zero calibration

To close "setting of Auto Zero Calibration"

To close the "Setting of Auto Zero Calibration" or cancel this mode midway, press the  key. A previous screen will return.

Auto calibration status contact output is closed during auto zero calibration (NO side), and is open in other cases.

Example

Start time	SUN	12:00
Cycle	12	hour
Flow time	300	sec
ON/OFF	ON	

In case where auto zero calibration is carried out at the above setting.

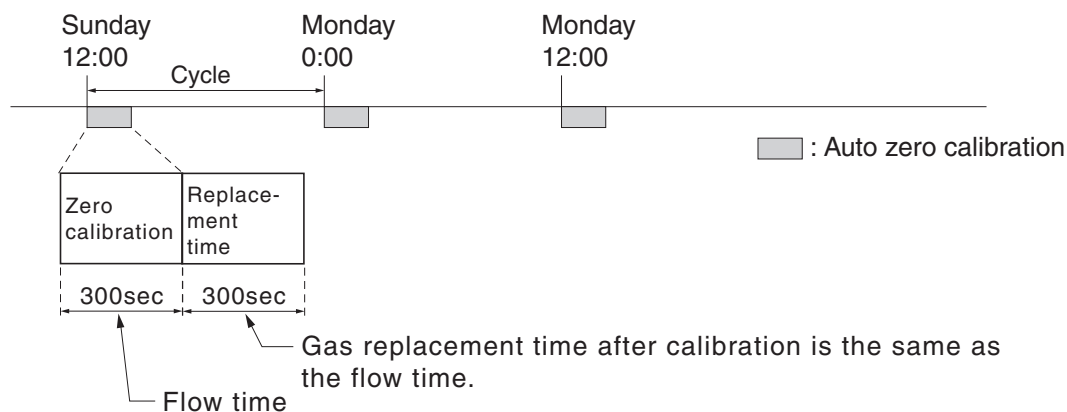

(An example of “Ch1: through Ch5: enable,” as given in Item 6.2.4 “Setting of auto calibration components/range”)

Setting range

Cycle : 1 to 99 hours or 1 to 40 days (initial value 7 days)
 Flow time : 60 to 900 sec (initial value 300 sec)

Caution

- When an auto zero calibration starts, the measurement screen automatically appears.
- Any operation other than “Auto Zero Calibration Stop” (see Item 6.5.2) is not permitted during auto zero calibration. “Auto Zero Calibration Stop” cannot be performed with the key lock to ON. To cancel auto zero calibration forcibly, set the key lock to OFF and then execute “Auto Zero CalibrationStop”.
- If the auto calibration period and auto zero calibration period have overlapped, the auto calibration is retained, ignoring the auto zero calibration of that period.
- When the hold setting is set to ON, the hold time of auto calibration contact and measurement value output signal is extended after calibration for gas replacement time.

Remote start

Whether the auto zero calibration is set at ON or OFF, an auto zero calibration is available by remote start input.

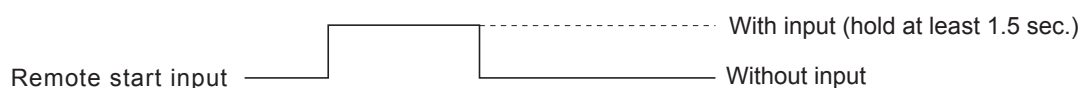

6.5.2 Forced run/stop of auto zero calibration

Auto zero calibration can be performed just once, or auto zero calibration can be forcibly stopped during calibration.

6.5.2.1 Execution of auto zero calibration (only once)

- (1) In the “Setting of Auto Zero Calibration” screen that appears, point the cursor to “Run” by pressing the \blacktriangle or the \blacktriangledown key. Press the ENT key.
- (2) “Run” is highlighted, displaying a message to confirm execution of auto zero calibration. Press the ENT key to execute the calibration, and press the ESC key to cancel.

Set Auto Zero Cal.	Auto zero Run ENT : Run / Stop ESC : Cancel
Start Time	SUN 12:00
Cycle	07 day
Flow Time	300 sec.
ON / OFF	OFF
Time : MON 12:34	
Auto Zero Calibration Run	

6.5.2.2 Forced stop of auto zero calibration

This mode is used to cancel the auto zero calibration forcibly.

- (1) In the “Setting of Auto Zero Calibration” screen that appears, point the cursor to “Stop” by pressing the \blacktriangle or the \blacktriangledown key. Press the ENT key.
(“Auto Zero Calibration Stop” appears when the screen is selected while auto zero calibration is performed.)
- (2) “Stop” is highlighted, displaying a message to confirm the stop of auto zero calibration. Press the ENT key to stop the auto zero calibration and the ESC key to cancel (not stopped).

Set Auto Zero Cal.	Auto Zero Stop ENT : Run / Stop ESC : Cancel
Start Time	SUN 12:00
Cycle	07 day
Flow Time	300 sec.
ON/OFF	OFF
Time : MON 12:34	
Auto Zero Calibration Stop	

“Auto Zero Calibration” screen

Example

In case where setting the auto calibration components (see Item 8.2.4) to “Ch1: enable” and “Ch2: enable”

- Zero calibration

A message, “Zero cal.” blinks at Ch1 and Ch2.

Ch 1	ZERO cal.	0.5 ppm
Ch 2	ZERO cal.	0.3 ppm
Ch 3	CO ₂ (0-10)	0.00 vol%
Ch 4	CO (0-200)	0.0 ppm
Ch 5	O ₂ (0-25)	21.02 vol%

Caution

During auto zero calibration, any key operation is not permitted other than operations such as key lock ON/OFF and “Auto Zero Calibration Stop.”

When the key lock is set at ON, even the “Auto Zero Calibration Stop” cannot be used.

To stop “auto zero calibration” forcedly, set the key lock to OFF and then execute “Auto Zero Calibration Stop.”

6.6 Parameter setting



It allows you to carry out the parameter setting such as time, key lock, etc., as required.

Items to be set are as follows:

Description of setting items



- Current Time : Current year, month, date, day of the week, hour, and minute setting
(The display appears in this order.)
Note) The clock backup time is 2 days. If power is turned on after it is kept off for 2 days or longer, make the time setting again.
- Key Lock : Invalidates any key operation except canceling the key lock.
- Output Hold : Sets whether Calibration Output is held or not, and the holding value setting.
- Response time : Sets the response time of electrical system.
- Average Period : Sets the moving average time.
- Backlight Timer : Sets automatic OFF of the backlight of display unit and the time until backlight out.
- Contrast : Adjusts contrast of the LCD.
- Maintenance mode : Enters passwords to switch to the Maintenance mode.

* For the maintenance mode, see Item 6.7.

- (1) Enter the “Parameter setting” screen from the user mode, and the display shown at right appears. Operate the  or the  key until the cursor is aligned with a desired item and press the  key.

Parameter	Select setting item
 Current Time	05/01/27 THU 13:50
Key Lock	OFF
Output Hold	OFF Current
Response Time	
Average Period	
Backlight Timer	ON 5 min
Contrast	
To Maintenance Mode	0000



- (2) In the “Parameter Setting” screen that appears, perform the value entry or the setting. For the value entry or setting change, use the  or the  key, and the  key move the cursor to the right.

Parameter	Set day of week
Current Time	05/01/27 THU 13:50
Key Lock	OFF
Output Hold	OFF Current
Response Time	
Average Period	
Backlight Timer	ON 5 min
Contrast	
To Maintenance Mode	0000



To close Parameter Setting screen

To close the “Parameter Setting” screen or cancel this mode midway, press the  key. A previous screen will return.

End of Parameter Setting

Setting Range

- Hold setting : 0 to 100% FS
- Response time : 1 to 60 sec. (Initial value: 15 sec)
- Average period : 1 to 59 min or 1 to 4 hours (Initial value: 1 hour)
1 to 59 minutes when the unit is set to minute and 1 to 4 hours when it is set to hour.
- Backlight Timer : 1 to 60 min (Initial value: 5 min)
- Maintenance mode : 0000 to 9999 (Initial value: 0000)

Output Hold

By setting an output hold to ON, an output signal of each channel are held during the manual/auto calibration and for the gas flow time (refer to Item 6.4, Setting of Auto Calibration). Regardless of Hold ON/OFF setting, an output signal can be held via an external input.

1 Manual calibration

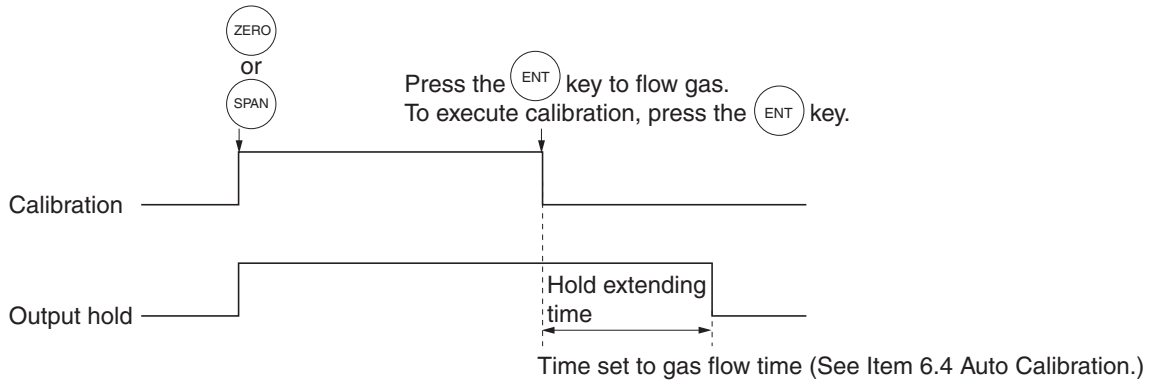

2 Auto calibration

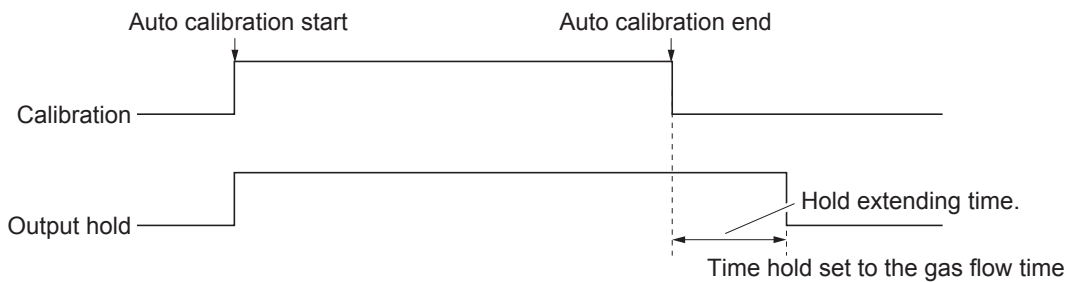

3 Remote hold

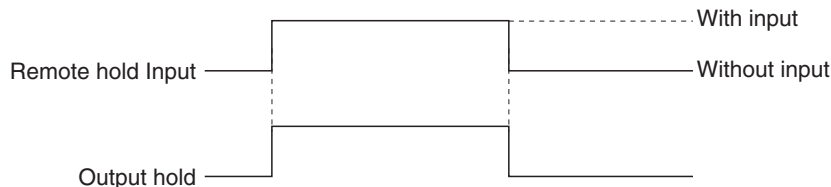





4 Screen display during Holding

The "Hold ON" message blinks on the measuring screen.

Since the screen displays the process of calibration during the manual calibration, "Hold ON" is not displayed even if the output signal is held, but the screen is displayed with the hold extending time.



- 5 If calibration is cancelled after the calibration gas is supplied regardless of during manual/auto calibration, the holding extending time will be performed.
- 6 You can select the value for hold from the value immediately before entering output hold, “current,” and arbitrary value, “setting.”

Follow the procedures shown below to make the setting.

- (1) In the “Parameter setting” screen that appears, select “Output Hold”.
“ON” or “OFF” is highlighted by pressing the  key. Press the  or the  key to select ON/OFF. Press the  key to return to (1).



Parameter	Select Hold ON or OFF
Current Time	05/01/27 THU 13:50
Key Lock	OFF
Output Hold	ON Current
Response Time	
Average Period	
Backlight Timer	ON 5 min
Contrast	
To Maintenance Mode	0000







- (2) Where ON/OFF is highlighted, press the  key. “Current” or “Setting” is highlighted. Select “Current” or “Setting” by pressing the  or the  key.

Parameter	Select Hold setting
Current Time	05/01/27 THU 13:50
Key Lock	OFF
 Output Hold	ON Setting
Response Time	
Average Period	
Backlight Timer	ON 5 min
Contrast	
To Maintenance Mode	0000



- (3) Press the  key while “Current” is selected to return to (1). Press the  key while “Setting” is selected to go to the parameter hold screen.
“Current”: Holds the value immediately before the hold.
“Setting”: Holds the value arbitrarily set.

- (4) On the parameter hold screen that appears, move the cursor next to the Ch (component) you want to make the setting by pressing the  or the  key, and then press the  key.

Parameter	Select Ch No.
Hold	
 Ch1	NO _x 010 %FS
Ch2	SO ₂ 020 %FS
Ch3	CO ₂ 015 %FS
Ch4	CO 012 %FS
Ch5	O ₂ 022 %FS



(5) The value is highlighted, indicating that the value can be changed. Change the value by pressing the ▲ or the ▼ key, and then move the cursor to the right digit by pressing the ► key.

(6) After the value is changed, press the ENT key.

Meaning of setting

The setting is expressed in % against the range for both ranges.

When 0 to 1000 ppm is selected as the range, for example, if 10% FS is selected as hold setting, the output equivalent to 100 ppm is output and held irrespective of the measurement value at that time.

(7) Press the ESC key to return to the parameter setting screen.

Description of setting

- Instantaneous value display of the measurement cannot be held. (Output only can be held.)
- If set value is selected for hold, instantaneous O₂ correction value is calculated and held based on the set value.
- Range identification contact output cannot be switched even if the range is switched during the hold.

Response time

The response time of the electrical system can be changed.

Setting is available by components.

Note) It does not provide exact seconds for the setting time, but it gives a guide of the setting time.

The setting value can be modified as requested by the customer.

↓ ENT

Parameter	Set Hold value
Hold	0 to 100%FS
Ch1 NO _x	010 %FS
Ch2 SO ₂	020 %FS
Ch3 CO ₂	015 %FS
Ch4 CO	012 %FS
Ch5 O ₂	022 %FS

↓ ENT

End of Hold Setting

↓ ESC





Parameter Setting screen

Parameter	Response Time	Select Ch No.
▣ Ch1 NO _x	10 sec.	
Ch2 SO ₂	20 sec.	
Ch3 CO ₂	15 sec.	
Ch4 CO	12 sec.	
Ch5 O ₂	22 sec.	

Backlight Timer

Automatic OFF setting of the backlight of the LCD unit can be made.



When the specified time elapses from when the measurement screen is resumed, the backlight is automatically turned off. Press any key to reset backlight OFF.

Only when ON is selected, the time until auto OFF is displayed. Press the  key in this state, and the time setting can be changed by pressing the  or the  key. Press the  key to confirm the selection.

If OFF is selected, the backlight is not turned off.

Parameter	Select ON or OFF
Current Time	05/01/27 THU 13:50
Key Lock	OFF
Output Hold	ON Previous value
Response Time	
Average Period	
Backlight Timer	<input checked="" type="checkbox"/> ON 5 min
Contrast	
To Maintenance Mode	0000

Contrast

Contrast of the LCD can be adjusted. The contrast changes by pressing the  or the  key. Adjust to the best contrast and determine it by the  key.

Parameter	Select ON or OFF
Current Time	05/01/27 THU 13:50
Key Lock	OFF
Output Hold	ON Previous value
Response Time	
Average Period	
Backlight Timer	ON 5 min
Contrast	
To Maintenance Mode	0000

Maintenance mode

Enter the password and then press the  key to enter the maintenance mode. The password can be set by the password setting in maintenance mode. Default password setting at the time of delivery from the factory is "0000." You can enter the maintenance mode with the value before the password is changed.

6.7 Maintenance mode

This mode is used for check of sensor input values, display of error log files or setting of passwords, etc. First, enter a password and then use it from the next operation. This mode is displayed by selecting the Maintenance Mode from “Item 6.7 Parameter Setting.”

- (1) Select the Maintenance Mode from the Parameter Setting screen to display the Password Setting screen.
- (2) Enter the password, and the Maintenance Mode item selection screen will be displayed. Point the cursor to the item you want to set by pressing the \blacktriangle or the \blacktriangledown key and press the ENT key.
- (3) Next, each Maintenance screen is displayed.

Note) “To Factory Mode” is used for our service engineers only.

- (4) Press the ESC key to return to the Maintenance Mode item selection screen from each screen.

Maintenance Mode	Select operating item
<input checked="" type="checkbox"/> 1. Sensor Input Value 2. Error Log 3. Cal. Log 4. Output Adj. 5. Other Parameter 6. To Factory Mode	



Each “Maintenance” screen

• Sensor Input Value screen

Description of Sensor Input Value screen

- Input 1 to 4 : NDIR sensor digital value
- Input 5 : O₂ sensor digital value

Maintenance Sensor Input	
Input 1	52107
Input 2	102129
Input 3	82134
Input 4	99257
Input 5	12530
<input checked="" type="checkbox"/> GAS Sample	

• Error Log screen

Description of Error Log screen

Error history. 14 newest errors are logged. For error number, date and time (year, month, day, period) of occurrence, channel and other details of error, refer to Item 8.1 Error message. Select Clear Error Log and press the ENT key, and the error log is cleared completely.

Maintenance Mode Error Log	ENT : Clear Error Log ESC : Back					
Error No.	Y	M	D	H	M	Ch
No. 4	04	2	11	18	10	5
No. 1	04	1	10	12	2	1
No. 6	03	12	1	10	10	2
No. 9	03	12	1	10	10	2
No. 5	03	12	1	0	0	2
No. 9	03	12	1	0	0	2
Next page						Page 1
<input checked="" type="checkbox"/> Clear Error Log						

• **Calibration Log screen**

Description of Calibration Log screen

Past calibration history.
 Sensor input value, concentration value, and the date when zero/span calibration is performed are logged. The 10 newest calibration data is logged by each component.
 Move the cursor to Clear Calibration Log and press the **(ENT)** key, and the calibration log is cleared completely.
 Z1 : Zero calibration (Z) of Range 1
 S1 : Span calibration (S) of Range 1
 Cnt : Value of measuring detector at the time of calibration
 Con : Concentration value displayed before calibration

Maintenance Cal. Log	Select Ch No.
<input checked="" type="checkbox"/> Ch1 NOx Ch2 SO2 Ch3 CO2 Ch4 CO Ch5 O2	
Clear Error Log	

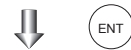







Maintenance Cal. Log Ch1 NOx			
R	Cnt	Con	Y D H M
Z1	00023	-0.2	12111810
S1	05439	189.5	12111810

• **Output adjustment screen**

Description of output adjustment screen

Analog output adjustment screen.
Connect the digital multi meter to the output terminal corresponding to the number of OUT to be adjusted, and adjust the value so that 4mA or 0V is output at zero and 20mA or 1V is output at span.

Move the cursor using the , , or the  key to the output (OUT No. and zero/span) to be adjusted, and then press the  key.

The selected value is highlighted. Adjust the value, while watching the output, by pressing the  or the  key. Press the  key to select the next digit.

On completion of the adjustment, press the  key.

Maintenance Mode Output Adj.			Adjust OUTPUT ZERO and SPAN		
OUT	Zero	Span	OUT	Zero	Span
1	00600	03700	7	00600	03700
2	00600	03700	8	00600	03700
3	00600	03700	9	00600	03700
4	00600	03700	10	00600	03700
5	00600	03700	11	00600	03700
6	00600	03700	12	00600	03700

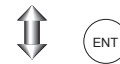

Maintenance Mode Output Adj.			Zero / Span adjustment		
OUT	Zero	Span	OUT	Zero	Span
1	00600	03700	7	00600	03700
2	00600	03700	8	00600	03700
3	00600	03700	9	00600	03700
4	00600	03700	10	00600	03700
5	00600	03700	11	00600	03700
6	00600	03700	12	00600	03700

• **Other parameter**

Description of each setting screen

Password Set : Set the password used to move from the parameter setting screen to the maintenance mode. Arbitrary 4-digit number can be selected.

O₂ ref. Value : Set the oxygen concentration reference value at the time of oxygen correction calculation. Settable in the range from 00 to 19%.



Limit : Set the oxygen concentration limit at the time of oxygen correction calculation. Settable in the range from 01 to 20%.

* Refer to the O₂ correction concentration value in “5.3 Outline of display screen” for oxygen correction calculation procedure.



Station No. : Set the station No. for MODBUS communication. Settable in the range from 00 to 32.

Range setting : Moves to the screen on which measuring range is changed.

Maintenance Mode setting	Select an item
Password Set 465 O ₂ ref. Value 12% O ₂ limit 20% O ₂ Station No. 01 Range setting	

Press the  or the  key to move the cursor to the item whose setting is to be changed.

The values for password, oxygen correction, limit, and station No. are highlighted.

Press the  or the  key to change the value to desired one, and then press the  key.

Note: Pay attention not to forget the password. Otherwise you cannot enter the maintenance mode.

<How to set/change the range>

The measuring range can be arbitrarily selected in the minimum and the maximum range specified at the time of purchase. The range to be used can be selected 1 or 2.

(1) Move the cursor to the item to be set by pressing the or the key, and then press the key.

(2) Move the cursor to the Ch (component) whose setting is to be changed by pressing the or the key, and then press the key.

(3) Move the cursor to the item whose setting is to be changed by pressing the or the key, and then press the key.

Settable range

The value for range 1 and range 2 must fall within the range from the MIN and the MAX range (including the MIN and the MAX range), and at the same time range 1 must be smaller than range 2.

The number of ranges is 1 or 2.

(4) Press the or the key to change the value. Press the key to select the next digit. The unit cannot be changed.

In a state where the decimal point is highlighted, press the or the key, and the decimal point position can be changed.

(5) When necessary change is made, press the key.

Maintenance Mode setting	Select an item
Password set 2465 O2 ref. Value 12% O2 limit 20% O2 Station No. 01 ▾ Range setting	



Maintenance Mode Range set	Select Ch No.
▾ Ch1 NOx Ch2 SO2 Ch3 CO2 Ch4 CO Ch5 O2	



Maintenance Mode Range Set Ch1 NOx	Select range or range num.
MIN range 100.0 ppm Range 1 500.0 ppm Range 2 1000. ppm ▾ MAX range 2000. ppm Range num. 2	



Maintenance Mode Range Set Ch1 NOx	Set range
MIN range 100.0 ppm Range 1 500.0 ppm Range 2 1000. ppm MAX range 2000. ppm Range num. 2	

Caution

Be sure to perform zero / span calibration when the range setting is changed. Otherwise, the measurement value may not be output properly.

6.8 Calibration

6.8.1 Zero calibration

It is used for zero point adjustment. For zero calibration gas, suited for an application should be used according to “(3) Standard gas in Item 3.3 Sampling.”

- Press the **ZERO** key on the Measurement screen to display the Manual Zero Calibration screen.

- Select the Ch (component) to be calibrated by pressing the **▲** or the **▼** key. After selection, press the **ENT** key, and zero gas will be supplied.

Caution

For the Ch (components) that is set to “both” in the “Zero Calibration” of the Calibration Setting mode, zero calibration is also carried out at the same time.

- Wait until the indication is stabilized with the zero gas supplied. After the indication has been stabilized, press the **ENT** key. Zero calibration in range selected by the cursor is carried out.

Note: For the Ch (component) for which “AR” is selected in “6.1.1 Setting range switch mode,” the cursor automatically moves to the range selected in “Setting of auto calibration component/range” (6.2.4), and calibration is carried out within that range.

To close "Zero Calibration"

To close the “Zero Calibration” or cancel this mode midway, press the **ESC** key. A previous screen will return.



ZERO Cal.	Select Ch No. with UP / DOWN and ENT Back with ESC	
▶ Ch1 NO _x	▶ Range1 0-200.0ppm Range2 0-2000 ppm	0.0
▶ Ch2 SO ₂	▶ Range1 0-200.0ppm Range2 0-2000 ppm	0.0
▶ Ch3 CO ₂	▶ Range1 0-10.00vol% Range2 0-20.00vol%	0.00
▶ Ch4 CO	▶ Range1 0-200.0ppm Range2 0-1000 ppm	0.0
▶ Ch5 O ₂	▶ Range1 0-10.00vol% ▶ Range2 0-25.00vol%	20.09



ZERO Cal.	Select Ch No. with UP / DOWN and ENT Back with ESC	
▶ Ch1 NO _x	▶ Range1 0-200.0ppm Range2 0-2000 ppm	0.0
▶ Ch2 SO ₂	▶ Range1 0-200.0ppm Range2 0-2000 ppm	0.0
▶ Ch3 CO ₂	▶ Range1 0-10.00vol% Range2 0-20.00vol%	0.00
▶ Ch4 CO	▶ Range1 0-200.0ppm Range2 0-1000 ppm	0.0
▶ Ch5 O ₂	▶ Range1 0-10.00vol% ▶ Range2 0-25.00vol%	20.09



ZERO Cal.	ENT : Go on calibration of selected Ch. ESC : Not calibration	
Ch1 NO _x	▶ Range1 0-200.0ppm Range2 0-2000 ppm	▶ 0.0
Ch2 SO ₂	▶ Range1 0-200.0ppm Range2 0-2000 ppm	▶ 0.9
Ch3 CO ₂	▶ Range1 0-10.00vol% Range2 0-20.00vol%	▶ 0.34
Ch4 CO	▶ Range1 0-200.0ppm Range2 0-1000 ppm	▶ 1.1
Ch5 O ₂	▶ Range1 0-10.00vol% ▶ Range2 0-25.00vol%	▶ 20.09



To Measurement screen after executing Manual Zero Calibration



6.8.2 Span calibration

It is used to perform a span point adjustment. Supply calibration gas with concentration set to the span value to perform the span calibration. For the span calibration gas for the NO_x, SO₂, CO₂, CO measurement, use the standard gas with a concentration of 90% or more of the range value. For the span calibration gas for the O₂ measurement, use the standard gas with a concentration of 90% or more of the range value when measuring with the built-in O₂ sensor, and use the standard gas of about 2 vol% when measuring with an external zirconia O₂ sensor.

- (1) Press the  key on the Measurement screen to display the Manual Span Calibration screen.

↓ 

SPAN Cal.		Select Ch No. with UP / DOWN and ENT Back with ESC	
<input checked="" type="checkbox"/> Ch1 NO _x	▶Range1 0-200.0ppm ▶Range2 0-2000 ppm	0.0	
Ch2 SO ₂	▶Range1 0-200.0ppm ▶Range2 0-2000 ppm	0.0	
Ch3 CO ₂	▶Range1 0-10.00vol% ▶Range2 0-20.00vol%	0.00	
Ch4 CO	▶Range1 0-200.0ppm ▶Range2 0-1000 ppm	0.0	
Ch5 O ₂	▶Range1 0-10.00vol% ▶Range2 0-25.00vol%	20.09	

- (2) Select Ch (component) to be calibrated by pressing the  or the  key and press the  key. The calibration gas is supplied.

Caution





When “both” from “Calibration Range” of the Calibration Setting mode is set, span calibration is performed together with 2 Ranges.

- (3) Wait until the indication is stabilized in the state where the calibration gas is supplied. After the indication has been stabilized, press the  key. Span calibration of Range selected by the cursor is performed.

Note: For the Ch (component) for which “AR” is selected in “6.1.1 Setting range switch mode,” the cursor automatically moves to the range selected in “Setting of auto calibration component/range” (6.2.4), and calibration is carried out within that range.

To close "Span Calibration"

To close the “Span Calibration” or cancel this mode midway, press the  key. A previous screen will return.

↓    

SPAN Cal.		Select Ch No. with UP / DOWN and ENT Back with ESC	
Ch1 NO _x	▶Range1 0-200.0ppm ▶Range2 0-2000 ppm	0.0	
<input checked="" type="checkbox"/> Ch2 SO ₂	▶Range1 0-200.0ppm ▶Range2 0-2000 ppm	0.0	
Ch3 CO ₂	▶Range1 0-10.00vol% ▶Range2 0-20.00vol%	0.00	
Ch4 CO	▶Range1 0-200.0ppm ▶Range2 0-1000 ppm	0.0	
Ch5 O ₂	▶Range1 0-10.00vol% ▶Range2 0-25.00vol%	20.09	

↓ 

SPAN Cal.		ENT : Go on calibration of selected Ch. ESC : Not calibration	
Ch1 NO _x	▶Range1 0-200.0ppm ▶Range2 0-2000 ppm	<input checked="" type="checkbox"/>	0.0
Ch2 SO ₂	▶Range1 0-200.0ppm ▶Range2 0-2000 ppm	<input checked="" type="checkbox"/>	0.9
Ch3 CO ₂	▶Range1 0-10.00vol% ▶Range2 0-20.00vol%	<input checked="" type="checkbox"/>	0.34
Ch4 CO	▶Range1 0-200.0ppm ▶Range2 0-1000 ppm	<input checked="" type="checkbox"/>	1.1
Ch5 O ₂	▶Range1 0-10.00vol% ▶Range2 0-25.00vol%	<input checked="" type="checkbox"/>	20.09

↓ 

**To Measurement screen after
executing Manual Span Calibration**

7. MAINTENANCE

7.1 Daily check

(1) Zero calibration and span calibration

- (1) Perform zero calibration. For the calibration procedures, refer to “Item 6.8.1 Zero calibration.”
- (2) Then, perform span calibration. For the calibration procedures, refer to “Item 6.8.2 Span calibration.”
- (3) Zero/span calibration should be carried out once a week, as required.

(2) Flow rate check

- (1) Sampling gas flow and purge gas flow are as follows:
 - Sampling gas flow : 0.5L/min ± 0.2L/min
 - Purge gas flow : About 1L/min
- (2) Check and maintenance should be carried out every day, as required.

7.2 Daily check and maintenance procedures

Table 7.1 Maintenance and check table

	Parts to be checked	Phenomena		Remedy
Daily check	Indication value	Indication values are lowered. Indication values are higherd.	(1) Dust is mixed in sampling cell.	(1) Clean the sampling cell. In addition, check sampling devices, especially gas filter.
			(2) Air is absorbed midway in the sampling pipe.	(2) Find out cause of leak and repair.
	Sampling gas flow rate (Purge gas flow is included when purging).	Comes off from regulated flowing quantity (0.3L/min to 0.7L/min).	_____	Adjust by needle valve of flow rater.
Weekly check	Zero point of gas analyzer	It is deflected from zero point.	_____	Zero adjustment
	Span point of gas analyzer	It is deflected from standard.	_____	Span adjustment
Yearly check	Gas analyzer	Regardless of any phenomena	_____	Overhaul

7.3 Cleaning of sampling cell

Entry of dust or water drops in the sampling cell contaminates the interior of the cell, thus resulting in a drift. Clean the inside if dirty. Then, check the sampling device, especially the filter, to prevent the cell from being contaminated by dust or mist.

7.3.1 Disassembly and assembly of sampling cell

There are two kinds of sampling cells, on block cells (cell length: 4 mm, 8 mm, 16 mm, 32 mm) and pipe cells (Cell length: 64 mm, 125 mm, 200 mm and 250 mm).

2-component analyzer may incorporate both sampling cells in optical unit. In such a case, detach the pipe cell and then block cell (See Fig. 7-3).

(1) How to remove pipe cell (See Fig. 7-1)

- 1) Stop measured gas. If it is harmful, purge in the measuring cell thoroughly with zero gas.
- 2) Turn OFF the power switch.
<In case of UL model>
The power switch is on the right side when facing the rear panel of the analyzer unit.
- 3) Pull out the internal case (with loose four screws on the front panel and a screw on the rear panel).
- 4) Remove the tube connected to the sampling cell.
- 5) Loosen and remove a screw (No. 7) from the cell retainer (No. 11) fastening the pipe cell.
- 6) Remove the cell from the measuring unit and unscrew the infrared transmission window (No. 14) at the both ends in the right direction.
- 7) For assembly, reverse the disassembly procedure.

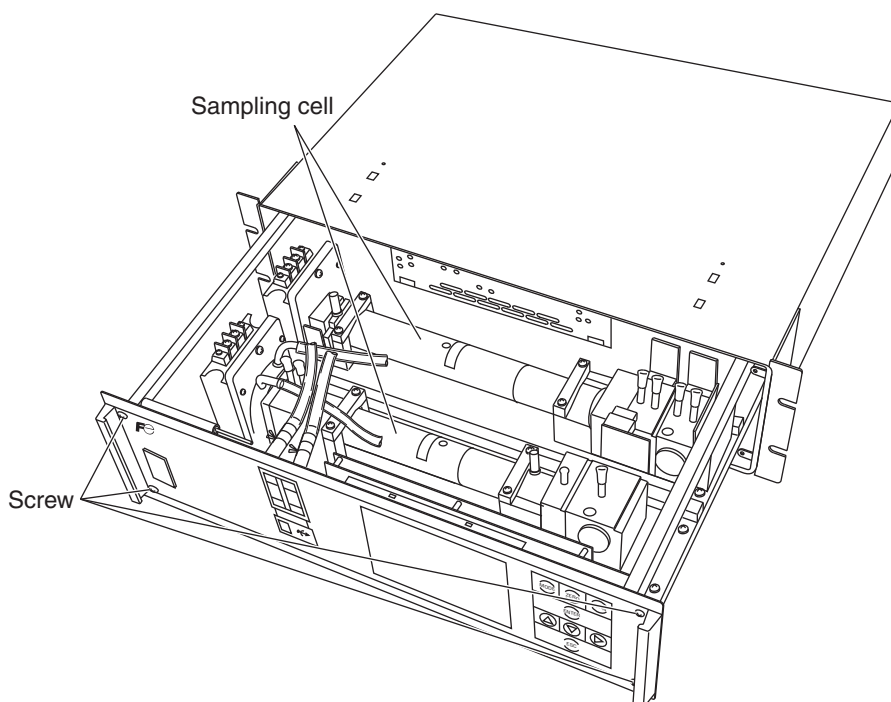

No.	Name
1	Screw (for fixing the light source unit)
2	Screw (for fixing the detector)
3	Screw (for fixing the gas filter)
4	Base plate
5	Light source unit
6	Screw (for fixing the support)
7	Screw (for fixing the cell retainer)
8	Gas filter
(9)	Filter
10	Support
11	Cell retainer
12	Pipe cell
13	O-ring
14	Infrared transmission window
15	Detector

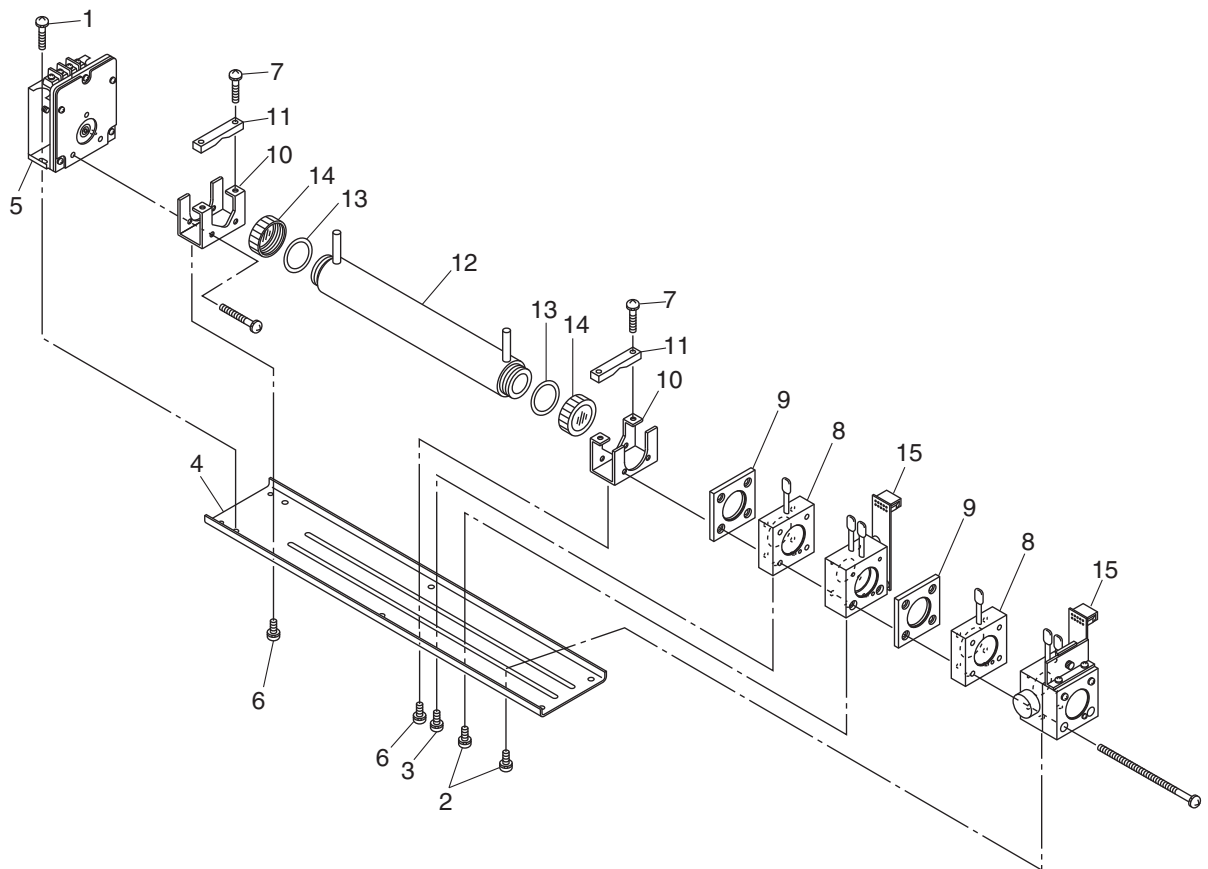

Fig. 7-1 Configuration of measuring unit (pipe cell)

(2) How to remove block cell (See Fig. 7-2)

- 1) For Step 1) to 4), see Item 7.3.1, (1) How to remove pipe cell.
- 5) Remove the connector to the detector output cord from the printed board.
- 6) Unscrew the two screws (No. 10) that hold the detector to the infrared ray light source unit to remove the detector from the measuring unit. The cell can be removed together with the detector.
- 7) To remove the cell, unscrew the two screws (No. 6) holding the cell to the detector. The infrared transmission window (No. 8) is just sandwiched (not fixed) between the detector and block cell. Keep the detector facing up, when removing this window.
- 8) For assembly, reverse the disassembly procedures.

Note) The O-ring (No. 9) is placed between the window holder and cell. Take care about the O-ring position. With 2-component analyzer, install 2-component detector last. Take care so that no space is left between the 1-component and 2-component detectors. When inserting the detector output cord connector into the printed board, be careful about the plugging position.

No.	Name
1	Screw (for fixing the light source unit)
(2)	Filter
3	Screw (for fixing the detector)
4	Base plate
5	Light source unit
6	Screw (for fixing the block cell)
7	Block cell
8	Infrared transmission window (window holder)
9	O-ring
10	Screw (for fixing the measuring unit)
11	Gas filter
12	Detector

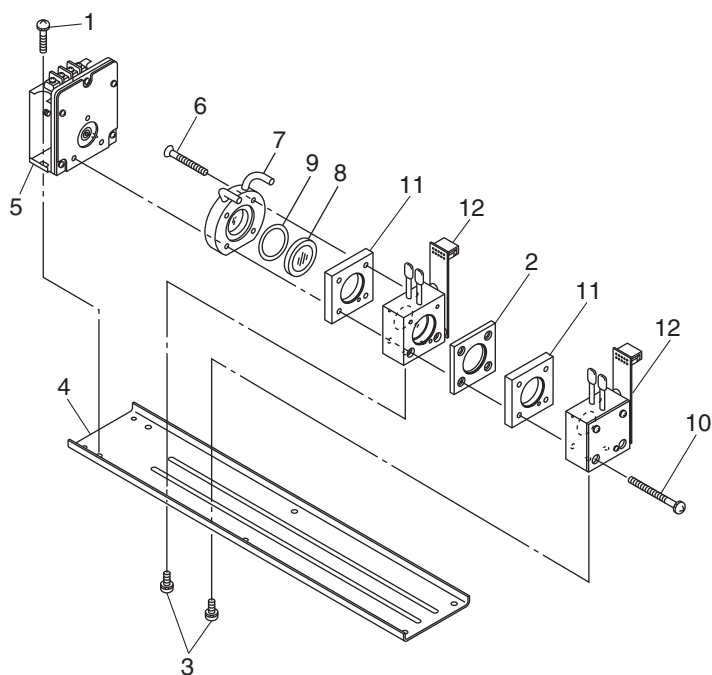

Fig. 7-2 Configuration of measuring unit (block cell)

(3) How to remove measuring unit (See Fig. 7-3)

- 1) For Step 1) to 4), see Item 7.3.1(1), How to remove pipe cell.
- 5) Remove the detector output cord connector from the printed board.
- 6) Remove wiring to the 2-pin terminals of the infrared ray light source assembly and chopper motor pin connector from the printed board.
- 7) Detach the six screws (No. 16) fastening the base plate (No. 3) to remove the measuring unit.
- 8) For assembly, reverse the disassembly procedures.

Note) Special care should be taken when assembling or disassembling the measuring cell to avoid the application of force to the detector pipe or infrared ray light source unit pipe. If the pipe is deformed or damaged by excessive force, there is a danger of gas leak, thus resulting in misoperation.

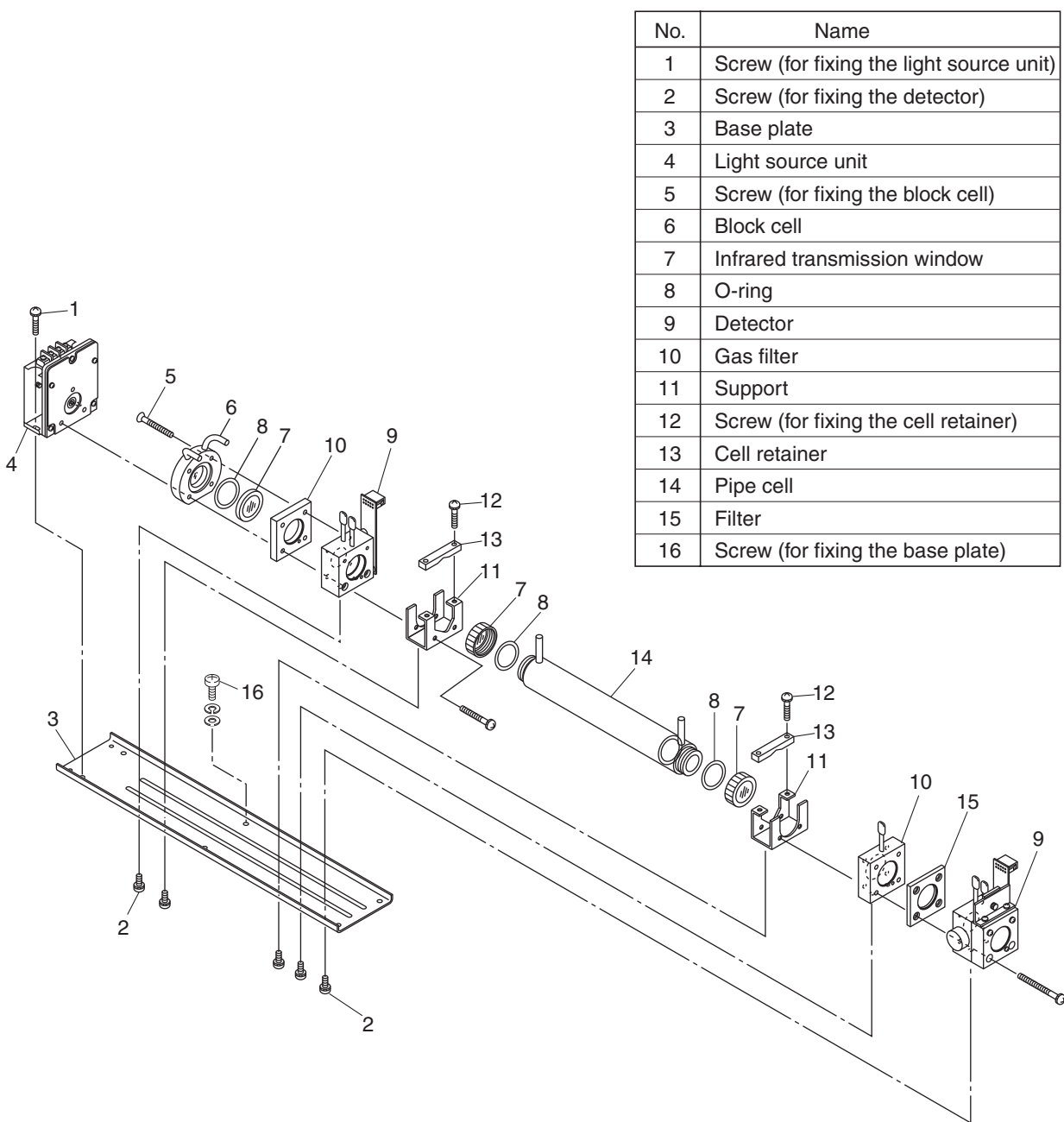

Fig. 7-3 Configuration of measuring unit (2-component analyzer: block cell + pipe cell)

7.3.2 How to clean cell

- 1) To clean the cell inside or infrared ray transmission window, first clear large dirt of it with a soft brush and then wipe with soft cloth lightly.
Don't use hard cloth.

Note) Handle the fragile window with care. Use care not to rub off the dirt from the window roughly.

- 2) If the window or the cell interior is very dirty, use a soft cloth moistened with absolute alcohol.
- 3) If the window is corroded, rub off the scale from the window lightly with a soft cloth to which chrome oxide powder is applied. If it is excessively corroded, it should be replaced with new one.
- 4) When the cell or window cleaning is completed, assemble according to the cell disassembly and assembly procedures. Especially, the pipe should be closely connected without gas leak, and repair if the pipe is bent.
- 5) Avoid washing the cell with water.

7.4 Cleaning of Enclosure

- 1) To clean the enclosure of the analyzer, first clear large dirt of it with a soft brush and then wipe lightly with soft cloth.
- 2) If the enclosure of the analyzer is very dirty, use a soft lint-free cloth moistened with absolute alcohol.
- 3) Do not wash the enclosure of the analyzer with water.

7.5 Adjustment in heat treatment furnace

• What is the adjustment in heat treatment furnaces?

If, in plant gases to be measured actually, a large amount of other lower-molecular-weight gases than nitrogen (N₂) such as hydrogen (H₂), or a large amount of other higher-molecular-weight gases than nitrogen (N₂) such as argon (Ar) are contained, including the measuring components, it is known that the calibration curve (output performance to gas concentration) of gas analyzers will be affected (pressure broadening).

In such a case, analyzer is adjusted with gases similar to plant gas compositions in manufacturing (adjustment by scale gas). After this adjustment, the analyzer is checked the calibration curve with N₂ balance gas (calibration curve by check gas). Graphs with these calibration curves drawn are attached to products to be supplied.

Since measurement in a heat treatment furnace has much gas of such composition, it is considering as the adjustment for heat treatment furnaces.

In order to perform exact measurement, perform the following span calibration.

Composition of the standard gas for span calibration used for each method and its method are explained using an example. For the standard gas for zero calibration, use N₂ or Air in any case so that zero point will not be affected.

<Example> Assume that a 0-1% CO₂ meter of the infrared ray gas analyzer measures CO₂ contained in plant gases.

When plant gases are composed of 0.5% CO₂, 23% CO, 30% H₂, 0.2% CH₄ and 44.3% N₂, either of the following is used as the span calibration standard gas.

	Standard gas type	Composition of standard gas	Method for span adjustment
1	Standard gas with the same composition as plant gases (scale gas)	0.9% to 1% CO ₂ , 25%CO, 30%H ₂ , remaining N ₂ *	Perform span calibration directly.
2	Check gas	0.9% to 1% CO Remaining N ₂	Perform span calibration indirectly.

* A small amount of gas like 0.2% CH₄ with little effect on span calibration may be excluded from the standard gas.

(1) Method for span calibration by standard gas with the same composition as plant gas

When using the standard gas with the same composition as plant gases given in 1, calibration can be performed without correction, as an error in calibration curve does not occur.

- 1) Set CO₂ concentration to span calibration concentration set value.
- 2) Perform span calibration by using the operation key.

(2) Method for span calibration by check gas

The method for span calibration by use of check gas (give in 2) is explained. Since span calibration has an error of calibration curve, preset a calibration indication on the calibration curve graph attached to this analyzer for indirect calibration.

- 1) The following calibration curve graph is attached to the test results for the product. In graph, the calibration curve by the scale gas (that is similar to plant gas and determines scales of this analyzer) and the calibration curve by the check gas that is adjusted by the scale gas (gas of simple composition of N₂ balance gas to facilitate the analyzer check) are drawn.

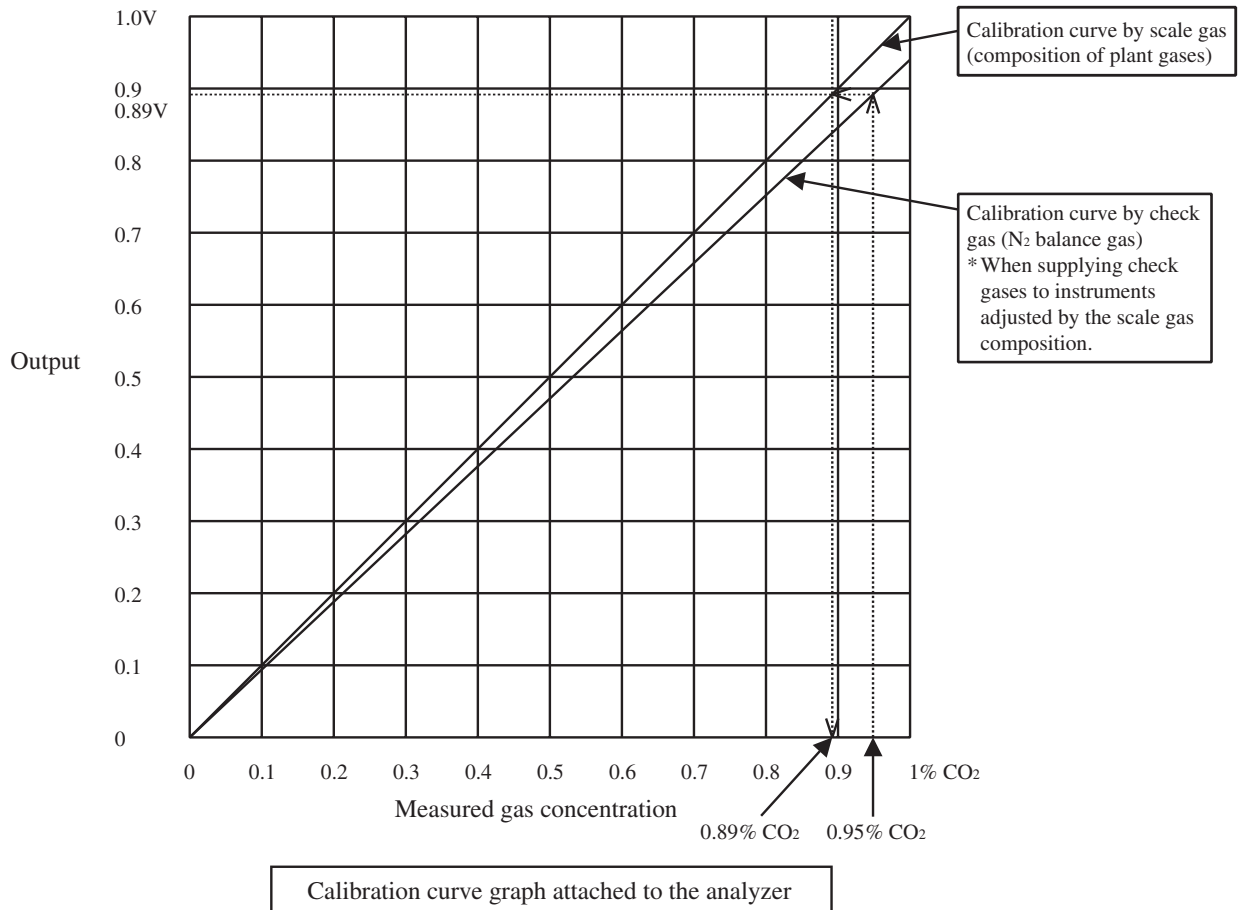

- 2) When using 0.95% CO₂ and remainder N₂ (check gas) as calibration gas, in graph, a point of 0.95% on X-axis should be stretched to upward, draw a line toward Y-axis from the cross point with the check gas calibration curve. From the cross point with calibration curve on the scale gas composition, 0.89% or equivalent values can be obtained.
- 3) Set this point (0.89%) to the span calibration concentration of the calibration concentration set value.
- 4) Supply 0.95% check gas to perform span calibration. It is calibrated to 0.89%. Measurement suited to actual plants can be performed by this error correction of calibration curve.

8. ERROR MESSAGE

If errors occur, the following contents are displayed.

Error display	Error contents	Probable causes
Error No.1	Light source/motor rotation is faulty.	<ul style="list-style-type: none"> • Infrared light source is faulty. • Sector motor is not properly run or is stopped. • Amplifier circuit is faulty.
Error No.2	Detector failure	<ul style="list-style-type: none"> • Detector voltage circuit is faulty. • Detection element is broken or faulty. • Amplifier circuit is faulty.
Error No.3	A/D error	<ul style="list-style-type: none"> • A/D conversion circuit is failure.
Error No.4	Zero calibration is not within.	<ul style="list-style-type: none"> • Zero gas is not supplied. • Zero is deflected much due to dirty cell. • Detector is faulty.
Error No.5	Amount of zero calibration (indication value) is over 50% of full scale.	
Error No.6	Span calibration is not within the allowable range.	<ul style="list-style-type: none"> • Span gas is not supplied. • Calibrated concentration setting does not match cylinder concentration. • Zero calibration is not performed normally. • Span is deflected much due to dirty cell. • Detector sensitivity has deteriorated.
Error No.7	Amount of span calibration (difference between indication value and calibrated concentration) is over 50% of full scale.	
Error No.8	Measured values fluctuate too much during zero and span calibration.	<ul style="list-style-type: none"> • Calibration gas is not supplied. • Time for flowing calibration gas is short.
Error No.9	Calibration is abnormal during auto calibration.	<ul style="list-style-type: none"> • Error corresponding to No. 4 to No. 8 occurred during auto calibration.
Error No.10	Output cable connection is improper.	<ul style="list-style-type: none"> • DIO circuit is failure. • Internal wiring to the DIO circuit is broken.

When errors No. 1 to No. 3 and No. 10 occur, analyzing block error contact output is closed.

When errors No. 4 to No. 9 occurs, calibration error contact output is closed.

<Troubleshooting at the occurrence of error>

When errors No. 1 to No. 3 and No. 10 occurs, the analyzer is faulty. Contact your dealer or our sales office.

When errors No. 4 to No. 8 occurs, the calibration procedure may be incorrect.

Check the following items, and if error still occurs, contact us as shown above.

- (1) Is the calibration gas supplied in the analyzer?
- (2) Does the calibration operation match the supplied gas? (For example, zero calibration is performed while flowing the span gas.)
- (3) Does the supplied gas concentration match the gas concentration set at the calibration concentration setting?

Also, when errors No. 5 and No. 7 occurs, you can perform calibration forcibly, following the procedure shown below. Use it as fault recovery when calibration fails and calibration contents are missed.

Screen display and operation at the occurrence of error

In case of Error No. 1 to No. 4, No. 6, No. 8 to No. 10

Measurement screen

9	Error No.9	00.8	ppm
2	SO ₂ (0-200)	13.6	ppm
3	CO ₂ (0-10)	0.000	vol%
4	CO (0-200)	0.0	ppm
5	O ₂ (0-25)	21.00	vol%

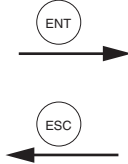

Display of error contents

Error No.9	Auto Cal. error ESC:Back to MEAS.
SPAN NOx Calibration error Cause	
<ul style="list-style-type: none"> • Calibration gas is not flowing • Gas flowing time is short • Setting conc. is different from gas conc. • Dirt in sample cell 	

- Press the **ESC** key to delete the error display.
- If the **ESC** key is pressed without removing the cause of an error, the error will be displayed again.

- When more than one error occurs, pressing the **▶** key moves to another error display.

In case of Error No. 5 and No. 7

ZERO cal.	ENT:Go on calibration of selected CH ESC:Not calibration		
Ch1 NO _x	Error No. 5	ppm	3083
Ch2 SO ₂	Range1 0-200 ppm Range2 0-2000 ppm		-13.6
Ch3 CO ₂	Range1 0-10 vol% Range2 0-20 vol%		-0.006
Ch4 CO	Range1 0-200 ppm Range2 0-1000 ppm		0.2
Ch5 O ₂	Range1 0-10 vol% Range2 0-25 vol%		-0.09



Error No. 5	SPAN cal. error ENT:Force Cal. ESC:Stop cal. and back to MEAS.
NOx Calibration error Cause	
<ul style="list-style-type: none"> • Span gas is not flowing • Deviation of zero point due to contamination • Low sensitivity of detector 	

- Pressing **ESC** deletes the error display.

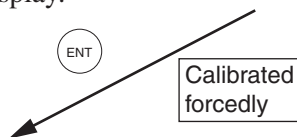

Calibration is continued. Unless another calibration error occurs, calibration is carried out to the end, the Measurement screen returns.

1	NO ₂ (0-25)	90.8	ppm
2	SO ₂ (0-200)	13.6	ppm
3	CO ₂ (0-10)	0.000	vol%
4	CO (0-200)	0.0	ppm
5	O ₂ (0-25)	0.09	vol%

Error log file

If error occurs, the history is saved in an error log file. The error log file exists in the maintenance mode.

Error log screen

Maintenance Mode Error Log	ENT : Clear Error Log ESC : Back					
Error No.	Y	M	D	H	M	Ch
No. 4	04	2	11	18	10	5
No. 1	04	1	10	12	2	1
No. 6	03	12	1	10	10	2
No. 9	03	12	1	10	10	2
No. 5	03	12	1	0	0	2
No. 9	03	12	1	0	0	2
Next page						Page 1
<input type="checkbox"/> Clear Error Log						

Annotations:

- Errors that occurred (points to the error log table)
- Date and time when an error occurred. (points to the H, M, Ch columns)
- Component with which the error occurred. (points to the Ch column)
- New (points to the top of the error list)
- Old (points to the bottom of the error list)

* Up to 14 errors can be saved in the error history; the oldest error will be deleted one by one every time a new occurs.

* If the power supply is turned OFF, the contents in the error log file will not be lost or damaged.

Deletion of error history

Press the **ENT** key on the above screen, and the “Error Log Clear” will be highlighted. Further pressing the **ENT** key will clear the error history.

9. SPECIFICATIONS

9.1 General specifications

Standard Specifications

Principle of measurement:

- NO, SO₂, CO₂, CO, CH₄ ;
 Non-dispersion infrared-ray absorption method
 Single light source and single beams (single beam system)
 O₂ ; Fuel cell O₂ sensor (built in) or zirconia O₂ sensor (externally installed TYPE: ZFK7)
 (Built in paramagnetic O₂ sensor will be next revision.)

Measurable gas components and measuring range:

	Minimum range	Maximum range
NO	0 - 200ppm	0 - 5000ppm
SO ₂	0 - 200ppm	0 - 10vol%
CO ₂	0 - 100ppm	0 - 100vol%
CO	0 - 200ppm	0 - 100vol%
CH ₄	0 - 500ppm	0 - 100vol%
O ₂ (built in fuel cell)	0 - 10vol%	0 - 25vol%
O ₂ (built-in Paramagnetic External Zirconia)	0 - 5vol%	0 - 25vol%

- Max. 5 components measurement including O₂.
- Measuring range ratio max. 1:10
- Measuring ranges are changeable between the specified minimum and maximum range
 Settable one range or two ranges
 For possible combinations of components and ranges, refer to Table1.

Measured value indication:

- Digital indication in 4 digits (LCD with back light)
- Instantaneous value of each component
 - Instantaneous value after O₂ correction (only in NO, SO₂, CO measurement with O₂)
 - Average value after O₂ correction (only in NO, SO₂, CO measurement with O₂)
 - O₂ average value

Analog output signals:

- 4 to 20mA DC or 0 to 1V DC, isolated internally from circuit and ground; 12 outputs max.
 max. load 550Ω for 4 to 20 mA DC
 min. load 100kΩ for 0 to 1V DC
 * Refer to Table2 for the channel No. of displayed values and analog output signals.

Analog input signal:

- For signal input from externally installed O₂ sensor.
 Signal requirement;
 (1) Signal from Fuji's Zirconia O₂ sensor (TYPE: ZFK7)
 (2) 0 to 1V DC from an O₂ sensor
 Input section is not isolated. This feature is effective when an O₂ sensor is not built in.
 * Externally installed O₂ sensor should be purchased separately.

Digital output: (Option)

- 1c contact (24V DC/1A, resistive load) max.15 outputs
 Instrument error, calibration error, range identification, auto calibration status, High/Low limit alarm contact output
 * All relay contacts are isolated mutually and from the internal circuit.

Digital input: (Option)

- Voltage contact (Supply 12 to 24V DC/15mA max. at ON) max. 9 inputs
 Remote range switch, auto calibration remote start, remote holding, average value resetting, Isolated from the internal circuit with photocoupler.

Power supply:

- Voltage rating ; 100V to 240V AC
 Allowable range ; 85V to 264V AC
 Frequency ; 50Hz/60Hz
 Power consumption ; 100VA max.

Operation conditions:

- Ambient temperature ;
 -5°C to 45°C
 (40°C max. when 2 optical system at 200V AC power source)
 Ambient humidity ; 90% RH max., non-condensing

Storage conditions:

- Ambient temperature ; -20°C to 60°C
 Ambient humidity ; 95% RH max., non-condensing

Dimensions (H × W × D):

- 19-inch rack mounting type:
 133 x 483 x 418mm
 Panel mounting type:
 133 x 443 x 418mm

Mass:

Approx. 8 kg

Finish color:

- Front panel; Black (DIC P 1000-F)
 Cool gray (PANTON IC-F)
 Casing; Cool gray (PANTON IC-F)

Enclosure:

Steel casing, for indoor use

Material of gas-contacting parts:

- Gas inlet/outlet; SUS304
 Sample cell; SUS304, chloroprene rubber
 Infrared-ray transmitting window; CaF₂
 Paramagnetic O₂ sensor cell : SUS316
 Fuel cell O₂ sensor cell : ABS resin
 Internal piping; Toaron, Teflon

Gas inlet/outlet: Rc1/4 or NPT1/4 internal thread

Purge gas flow rate: 1L/min (when required)

Life time of fuel cell O₂ sensor:

2 years

Standard Functions

Output signal holding:

Output signals are held during manual and auto calibrations by activation of holding (turning "ON" its setting).

The output to be held are the ones just before start calibration mode or setting value.

It is selectable.

Indication of instantaneous values will not be held.

Switch ranges: The switch ranges function is available in manual, auto, and remote modes. Only preset switch method is effective.

Manual: Allows range to switch by key operation.

Auto: Allows range to switch from low to high range when 90%FS or more is available in the low range.

Allows range to switch from high to low range when 80%FS or less is available in the low range.

Remote: (Option) Voltage contact input (for measurable components)

Allows range to switch via an external signal when remote range switch input is received.

When the contact input terminals for each component are input voltage, the first range is selected, and it is switched to the second range when the terminals are open.

* These range value are settable between original first range and second range.

Optional Functions

Remote output holding:

Output signal is held at the latest value or setting value by voltage input the remote output holding input terminals.

Holding is maintained while the voltage input the terminals. Indication of instantaneous values will not be held.

Range identification signal:

The present measuring range is identified by a contact signal.

The contact output terminals for each component turn on when the first range is selected, and when the second range is selected, the terminals are open.

Auto calibration:

Auto calibration is carried out periodically at the preset cycle.

When a standard gas cylinder for calibration and a solenoid valve for opening/closing the gas flow line are prepared externally by the customer, calibration will be carried out with the solenoid valve drive contacts for zero calibration and each span calibration turned on/off sequentially at the set auto calibration timing.

Auto calibration cycle setting:

Auto calibration cycle is set.

Setting is variable within 1 to 99 hours (in increments of 1 hour) or 1 to 40 days (in increments of 1 day).

Gas flow time setting:

The time for flowing each calibration gas in auto calibration is set.

Settable within 60 to 900 seconds (in increments of 1 second)

Auto calibration remote start:

Auto calibration is carried out only once according to an external input signal. Calibration sequence is settable in the same way as the general auto calibration. Auto calibration is started by opening the auto calibration remote start input terminals after input voltage for 1.5 seconds or longer.

Auto zero calibration:

Auto zero calibration is carried out periodically at the preset cycle.

This cycle is independent on "Auto calibration" cycle.

When zero calibration gas and solenoid valve for opening/closing the calibration gas flow line are prepared externally by the customer, zero calibration will be carried out with the solenoid valve drive contact for zero calibration turned on/off at the set auto zero calibration timing.

Auto zero calibration cycle setting:

Auto zero calibration cycle is set.

Setting is variable within 1 to 99 hours (in increments of 1 hour) or Setting is variable within 1 to 40 days (in increments of 1 day)

Gas flow time setting:

The timing for flowing zero gas in auto zero calibration is set.

Settable 60 to 900 seconds (in increments of 1 second)

High/low limit alarm:

Alarm contact output turns on when measurement value reach the preset high or low limit alarm value.

Contacts turn on when the channel value of each channel exceeds the high alarm limit value or falls below the low alarm limit value.

Instrument error contact output:

Contacts turn on at occurrence of analyzer error No. 1, 2, 3 or 10.

Calibration error contact output:

Contacts turn on at occurrence of manual or auto calibration error (any of errors No. 4 to 9).

Auto calibration status contact outputs:

Contacts turn on during auto calibration.

O₂ correction: Correction of measured NO, SO₂ and CO gas concentrations into values at reference O₂ concentration

Correction formula:

$$C = \frac{21-O_n}{21-O_s} \times C_s$$

C : Sample gas concentration after O₂ correction

C_s : Measured concentration of sample gas

O_s : Measured O₂ concentration (Limit setting: 1 to 20% O₂)

O_n : Reference O₂ concentration (value changeable by setting.0 to 19% O₂)

Average value after O₂ correction and O₂ average value calculation:

The result of O₂ correction or instantaneous O₂ value can be outputted as an average value in the preset period of time. Used for averaging is the moving average method in which sampling is carried out at intervals of 30 seconds.

(Output is updated every 30 seconds. It is the average value in the determined period of time just before the latest updating.)

Averaging time is settable within 1 to 59 minutes (in increments of 1 minute) or 1 to 4 hours (in increments of 1 hour).

Average value resetting:

The above-mentioned output of average value is started from the initial state by opening the average value resetting input terminals after input voltage for 1.5 seconds or longer.

Output is reset by input voltage and restarted by opening

Communication function:

RS-485 (9pins D-sub) or USB (Type-B)
Half-duplex bit serial
Start-stop synchronization
Modbus™ protocol

Contents : Read/Write parameters
Read measurement concentration and instrument status

Remark : When connecting via RS-232C interface, an RS-232C ↔ RS-485 converter should be used.

Performance

Repeatability: ±0.5% of full scale

Linearity: ±1% of full scale

Zero drift: ±2% of full scale/week

In the case of auto zero calibration use for 500 ppm or less range

Span drift: ±2% of full scale/week

Response time (for 90% FS response) :

1 to 15 sec electrical response

Within 60 seconds including replacement time of sampling gas (when gas flow rate is 0.5L/min)

Gas replacement time depends on the number of measuring components, and measuring range.

Interference from other gases:

Interference component	CO ₂ analyzer	CO analyzer	CH ₄ analyzer	SO ₂ analyzer	NO analyzer
CO 1000ppm	≤1%FS	—	≤1%FS	≤1%FS	≤1%FS
CO ₂ 15%	—	≤1%FS (for 200ppm analyzer, ≤2.5%FS)	≤1%FS	≤1%FS	≤1%FS
H ₂ O saturation at 20°C	≤1%FS	≤1%FS (for 500ppm analyzer, ≤2.5%FS)	≤1%FS	—	—
H ₂ O saturation at 2°C	—	≤2.5%FS (for 200ppm analyzer)	—	≤2%FS	≤2%FS
CH ₄ 1000ppm	≤1%FS	≤1%FS	—	≤50ppm	—

Standard Requirements for Sample Gas

Flow rate: 0.5L / min ±0.2L / min

Temperature: 0 to 50°C

Pressure: 10 kPa or less (Gas outlet side should be open to the atmospheric air.)

Dust: 100 µg/Nm³ or less in particle size of 0.3 µm or less

Mist: Unallowable

Moisture: Below a level where saturation occurs at room temperature (condensation unallowable).

Below the level where saturation occurs at 2°C for CO measurement in 0 to 200 ppm range, NO measurement, and SO₂ measurement.

Corrosive component:

1 ppm or less

Standard gas for calibration:

Zero gas ; Dry N₂

Span gas ; Each sample gas having concentration 90 to 100% of its measuring range (recommended).

In case a zirconia O₂ analyzer is installed externally and calibration is carried out on the same calibration gas line:

Zero gas ; Dry air or atmospheric air

Span gas ; For other than O₂ measurement, each sample gas having concentration 90 to 100% of its measuring range
For O₂ measurement, O₂ gas of 1 to 2 vol%/remains N₂ gas

Installation Requirements

- Indoor use (Select a place where the equipment does not receive direct sunlight, draft/rain or radiation from hot substances. If such a place cannot be found, a roof or cover should be prepared for protection.)
- Avoid a place where unit receives heavy vibration
- Select a place where atmospheric air is clean

EU Directive Compliance

LVD:

EN 61010-1
EN 62311

EMC:

EN 61326-1(Table 2)
EN 61000-3-2(Class A)
EN 61000-3-3
EN61326-2-3

RoHS:

EN IEC63000

Digit	Description	note	1	2	3	4	5	6	7	8	9	10	11	12	13	14	15	16	17	18	19	20	21	22	23	24	25	26	← Digit
24	<Unit> ppm, % mg/m ³ , g/m ³	note7	Z	R	E	A																							
25	<Adjustment> For standard For heat treatment furnace For steel converter furnace Others	note8 note9																											
26	<Others> None standard																												

<RANGE CODE>	
Range	Code
None	Y
0-100ppm	B
0-200ppm	C
0-250ppm	D
0-300ppm	S
0-500ppm	E
0-1000ppm	F
0-2000ppm	G
0-2500ppm	U
0-3000ppm	T
0-5000ppm	H
0-1%	J
0-2%	K
0-3%	Q
0-5%	L
0-10%	M
0-20%	N
0-25%	V
0-40%	W
0-50%	P
0-70%	X
0-100%	R
Others	Z

- note1) "A. Cal." must be specified at 22nd digit, in the case of 500 ppm or less range.
- note2) When only O₂ measurement is necessary, "Y" should be specified at the 6th digit.
- note3) When "1" is specified at 7th digit, O₂ pt sensor signal has to be set as 0-1V DC linear corresponding to full scale.
External zirconia O₂ sensor and external O₂ analyzer are not included in the scope of supply, and has to be separately ordered.a
- note4) Refer to Tables 1 for possible combination of measuring components and ranges in the data sheet.
When "Y" is specified at 6th digit, "Y" should be specified at 9th to 16th digit.
- note5) O₂ correction is calculated only for NO, SO₂ and CO
- note6) When 5 components measurement is specified, "H" must not be specified at 22nd digit.
When 4 components measurement is specified and "H" is specified at 22nd digit, 3 point is maximum for alarm output function.
- note7) When "B" is specified at 24th digit, measuring range should be specified by ppm range code.
In this case NO,SO₂ and CO measuring range are corresponding range in mg/m³.
Please refer to the table shown below for the corresponding range code based on "mg/m³".
- note8) When A to D is specified on the 25th digit, the analyzer will be adjusted and delivered with the following gasses.
Standard "A": balance gas N₂
For heat treatment furnace "C": balance gas 30%H₂ / remains N₂
For converter "D": balance gas CO, CO₂
When other adjustment is required, please specify "Z",
When "Z" is specified, please attach a list of gas composition contained in the measuring gas.
- note9) When the 25th code is "C", the range code "X" and "R" are not available.

Corresponding mg/m³

Range code	Unit : ppm	Corresponding range in mg/m ³		
		NO	SO ₂	CO
C	0-200ppm	0-260mg/m ³	0-570mg/m ³	0-250mg/m ³
D	0-250ppm	0-325mg/m ³	0-700mg/m ³	0-300mg/m ³
S	0-300ppm	0-400mg/m ³	0-850mg/m ³	0-375mg/m ³
E	0-500ppm	0-650mg/m ³	0-1400mg/m ³	0-600mg/m ³
F	0-1000ppm	0-1300mg/m ³	0-2800mg/m ³	0-1250mg/m ³
G	0-2000ppm	0-2600mg/m ³	0-5600mg/m ³	0-2500mg/m ³
U	0-2500ppm	0-3300mg/m ³	0-7100mg/m ³	0-3000mg/m ³
T	0-3000ppm	0-4000mg/m ³	0-8500mg/m ³	0-3750mg/m ³
H	0-5000ppm	0-6600mg/m ³	0-14.00g/m ³	0-6250mg/m ³

The conversion formula "ppm" unit into "mg/m³" unit.
 NO (mg/m³) = 1.34 × NO (ppm)
 SO₂ (mg/m³) = 2.86 × SO₂ (ppm)
 CO (mg/m³) = 1.25 × CO (ppm)

9.3 Outline diagram <Analyzer main unit>

(Unit : mm)

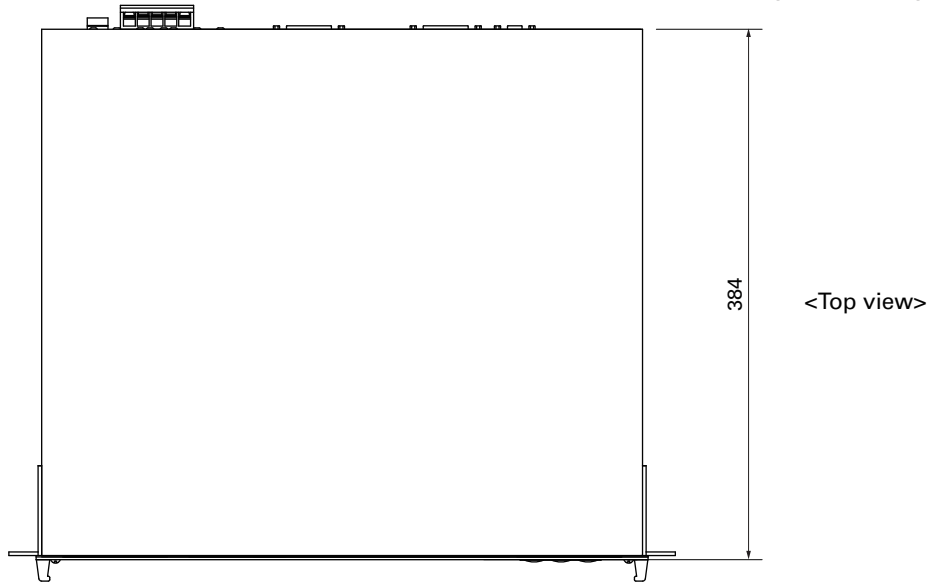

<In case of UL model>

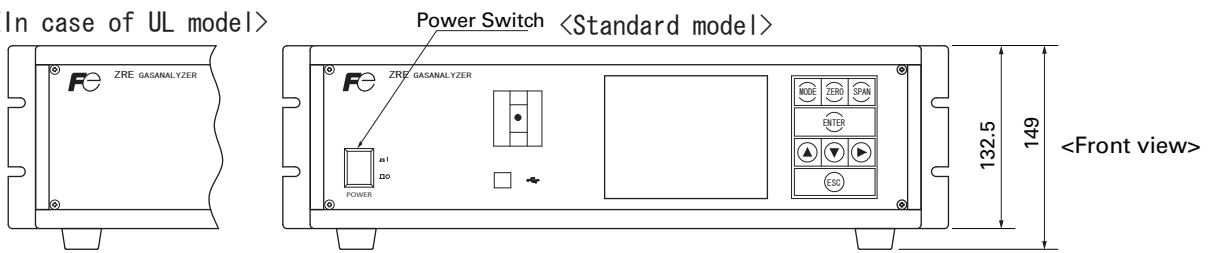

Digital input/output connector (DIO 1 to 3)

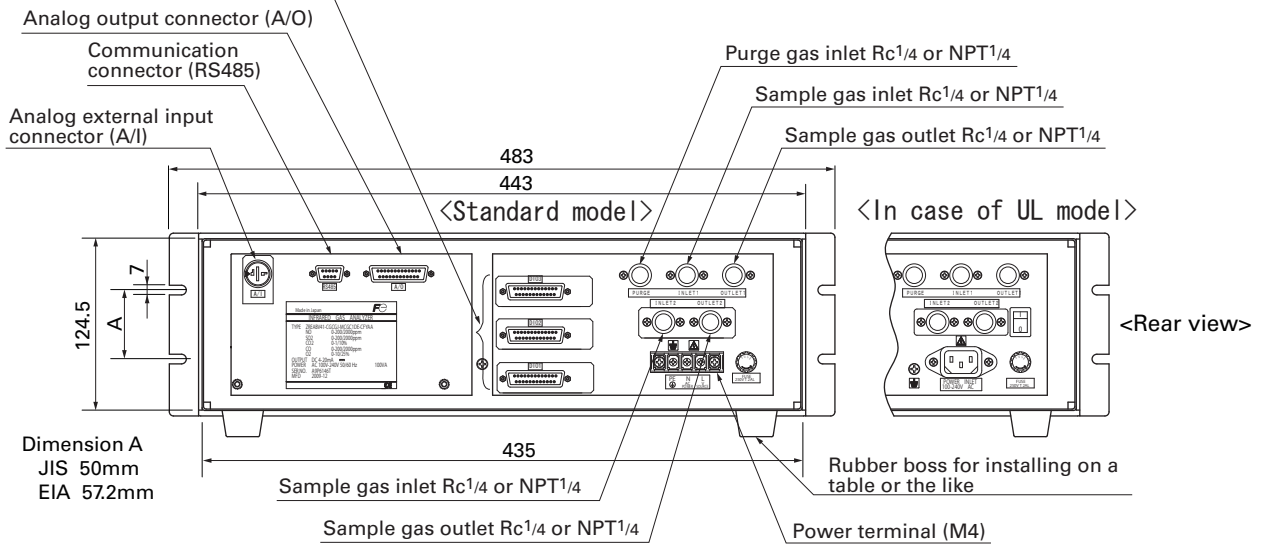



Gate City Ohsaki, East Tower, 11-2, Osaki 1-chome, Shinagawa-ku, Tokyo 141-0032, Japan
Phone: +81-3-5435-7111
www.fujielectric.com
www.fujielectric.com/products/instruments/
