



Instruction Manual

**INFRARED GAS
ANALYZER**

**COMMUNICATION
FUNCTIONS (MODBUS)**

TYPE: ZRE

CONTENTS

1.	COMMUNICATION FUNCTIONS	1
1.1	General.....	1
2.	SPECIFICATIONS	2
2.1	Communication specifications.....	2
3.	CONNECTION	3
3.1	Terminal allocation	3
3.2	Wiring	4
4.	SETTING OF COMMUNICATION CONDITION.....	6
4.1	Set items.....	6
4.2	Setting operation	6
4.3	Installing USB driver (Virtual COM port).....	6
5.	MODBUS COMMUNICATION PROTOCOL.....	7
5.1	General.....	7
5.2	Composition of message	8
5.3	Response of slave station	10
5.4	Function code.....	11
5.5	Calculation of error check code (CRC-16).....	12
5.6	Transmission control procedure.....	14
6.	DETAILS OF MESSAGE	16
6.1	Read-out of word data [Function code:03 _H]	16
6.2	Read-out of read only word data [Function code:04 _H]	18
6.3	Write-in of word data (1 word) [Function code:06 _H].....	20
6.4	Write-in of continuous word data [Function code:10 _H]	21
7.	ADDRESS MAP AND DATA FORMAT	23
7.1	Data format	23
7.2	Address map	25
7.3	Supplement to address map	37
8.	TROUBLESHOOTING	38

1.1 General

- This instrument provides a communication function through RS-485 and USB interface, which allows data transmit to or receive from the host computer and other devices.
- The communication system is comprised of a master station and slave stations. Up to 31 of slave station (present instrument) can be connected per master station (host computer, programmable controller, graphic display panel, etc.) through RS-485 interface. USB interface enables one-to-one connection.
- Because the master station can communicate with only one slave station at a time, the destination can be identified by the "Station No" set for each slave station.
- In order that the master station and the slave station can communicate, the format of the transmit/receive data must coincide. In this instrument, the format of the communication data is determined by the MODBUS protocol.

[RS-232 ↔ RS-485 converter] (recommended article)

Type: KS-485 (non-isolated type)/SYSTEM SACOM Corp.

Type: SI-30A (isolated type)/SEKISUI ELECTRONICS Co., Ltd.

[USB ↔ RS-485 converter] (recommended article)

Type: USB-485I/SYSTEM SACOM Corp.

Programable controller

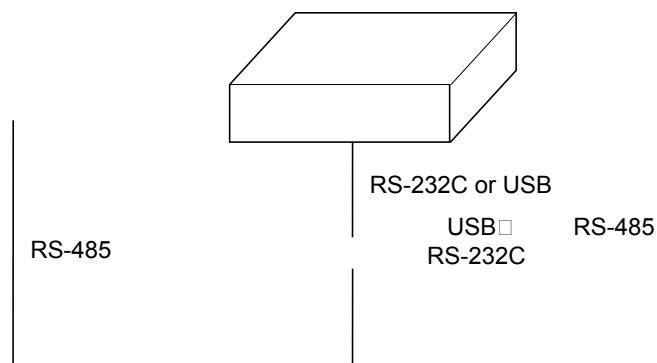

2. SPECIFICATIONS

2.1 Communication specifications

■ RS-485 interface

Item	Specification	
Electrical specification	Based on EIA RS-485	
Transmission system	2-wire, semi-duplicate	
Synchronizing system	Start-stop synchronous system	
Connection format	1 : N	
Maximum connectable units	31 units	
Transmission distance	500m max. (total extension distance)	
Transmission speed	38400bps	
Data format	Data length	8 bits
	Stop bit	1 bit
	Parity	None
	X flow control	None
Transmission code	HEX value (MODBUS RTU mode)	
Error detection	CRC-16	
Isolation	Isolation from internal circuit Functional isolation between signal line and ground	

■ USB interface

Item	Specification	
Electrical specification	Based on USB 2.0 (full speed)	
Connector	USB connector, B type	
Communication distance	3m	
Data format (Communication using virtual COM port)*	Communication speed	38400bps
	Data length	8 bits
	Stop bit	1 bit
	Parity	None
	X flow control	None
Transmission code	HEX value (MODBUS RTU mode) Error detection CRC-16	
Isolation	No isolation between signal and internal circuit Functional isolation between signal and ground	

*For the USB communication, install the USB driver in the attached CD-ROM, and use it as the virtual COM port.

3. CONNECTION

⚠ WARNING

Do not turn on the power supply until all wiring have been completed to avoid electric shock and malfunctions.

3.1 Terminal allocation

■ RS-485 interface (RS-485 connector at the rear panel)

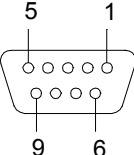
Pin No.	Signal name	Pin connection
1	Signal ground	 <p>9-pin D-Sub (female)</p>
2	RTxD+	
3	RTxD-	
Others	NC	

■ USB interface (USB connector at the front panel)

Applicable connector: USB connector, B type (for device)

USB interface on the analyzer side is operated with power from the USB side. Be sure to supply from the USB cable.

3.2 Wiring

■ RS-485 interface

- Please use a shielded twist pair cable. (Recommended cable: KPEV-SB (made by The Furukawa Electric Co., Ltd.))
- The maximum cable length should be 500m. One master and up to thirty-one micro controllers (slaves) can be connected per circuit.
- Terminate both ends of the circuit with a terminating resistance of 100Ω (1/2W or more).
- Ground the shielded cable once towards the master side.

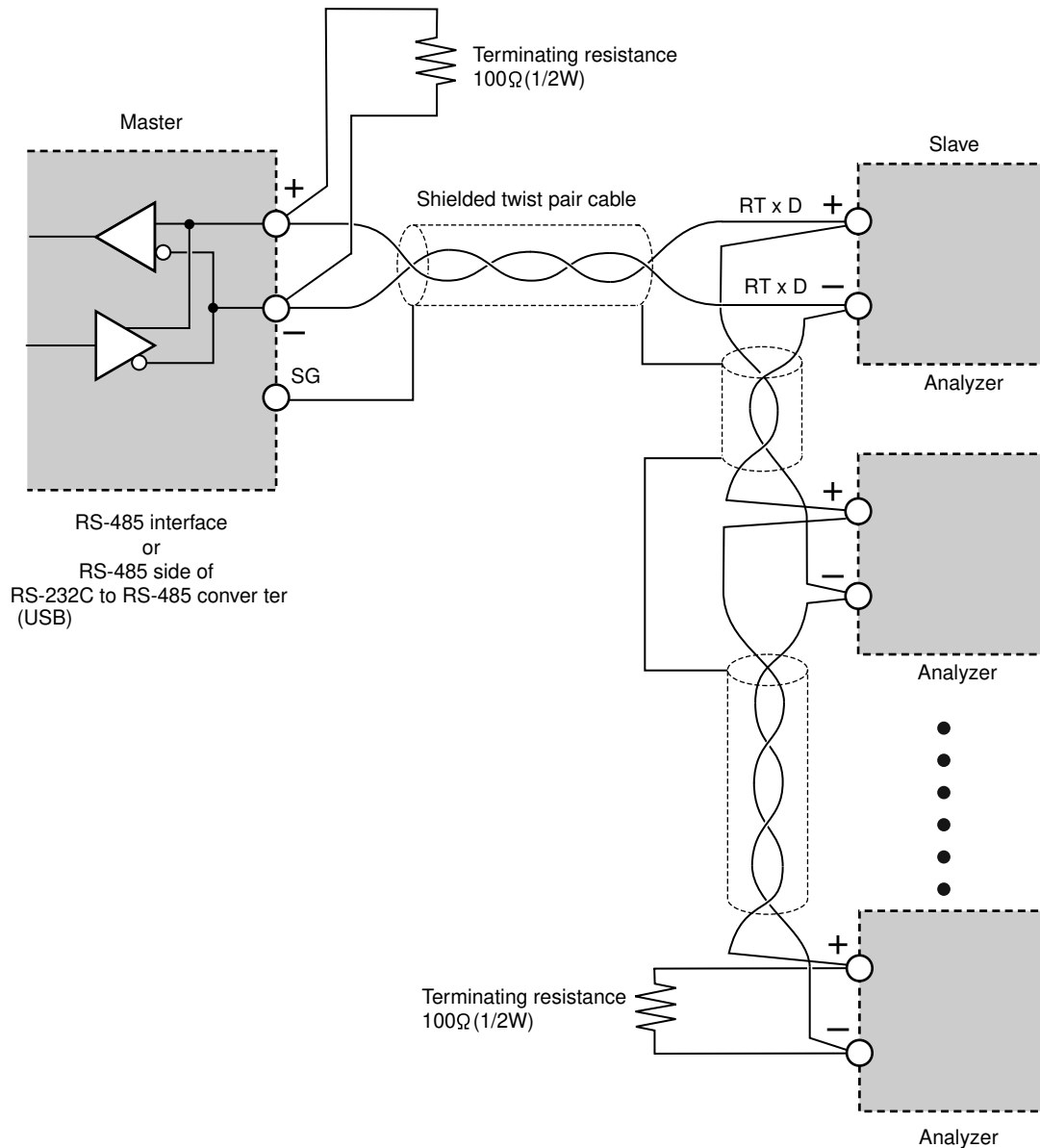

- SG does not have to be connected, but it can be used as an effective countermeasure against communication errors due to noise.

- When using the micro controller in an area where the imposed noise level is expected to exceed 500V, we recommend using a noise filter on the master side as seen in the figure below.

[Noise filter] (recommended): ZRAC2203-11 (made by TDK Corporation)

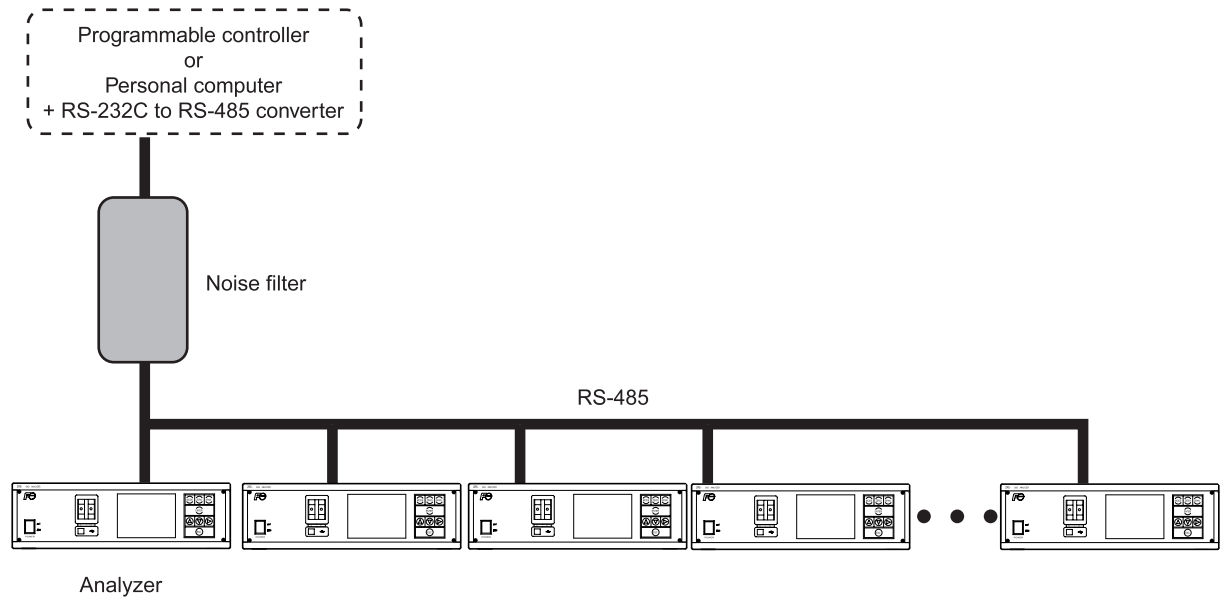

- If there are problems with EMC during communication, the noise level can be reduced by using a communication cable with a ferrite core.

Ferrite core (recommended): ZCAT series (made by TDK Corporation)

MSFC series (made by Morimiya Electric Co., Ltd.)

■ USB interface

- The commercially available USB cable (type A - B connector type) should be used.

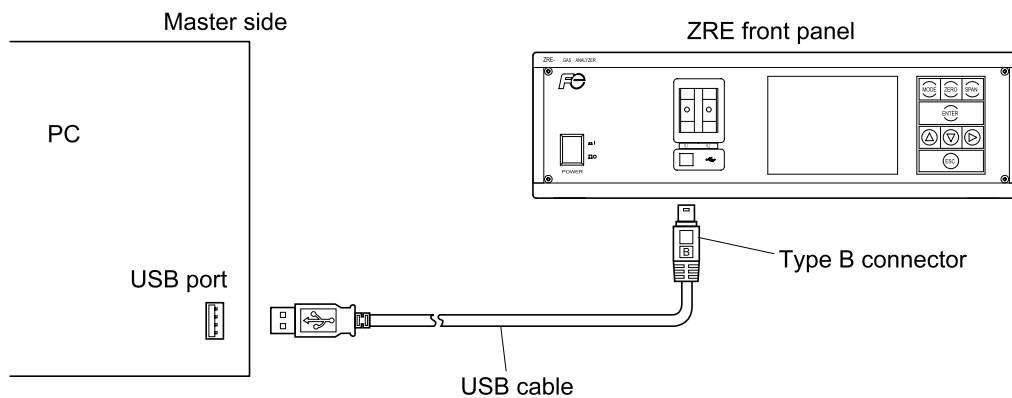

4. SETTING OF COMMUNICATION CONDITION

In order that the master station and instrument can correctly communicate, following settings are required.

- All communication condition settings of the master station are the same as those of instruments.
- All instruments connected on a line are set to "Station Nos. (STno)" which are different from each other. (Any "Station No." is not shared by more than one instrument.)

4.1 Set items

The parameters to be set are shown in the following table. Set them by operating the front panel keys.

Item	Value at delivery	Setting range	Remarks
Transmission speed	38400bps	Fixed (can not be changed)	Set the same communication condition to the master station and all slave stations.
Data length	8 bits	Fixed (can not be changed)	
Stop bit	1 bit	Fixed (can not be changed)	
Parity setting	None	Fixed (can not be changed)	
Station No.	1	0 to 31 (0:communication function stop)	Set a different value to each station.

4.2 Setting operation

Set the station No. on the analyzer maintenance mode display (see the instruction manual).

4.3 Installing USB driver (Virtual COM port)*

To perform communication through USB, refer to the installation manual in the attached CD-ROM, and then install the driver. Be sure to perform installation before connecting to the analyzer.

*The virtual COM port equates the USB port with serial communication port (the same control against the serial port).

5. MODBUS COMMUNICATION PROTOCOL

5.1 General

The communication system by the MODBUS protocol is that the communication is always started from the master station and a slave station responds to the received message.

Transmission procedures is as shown below.

- 1) The master station sends a command message to a slave station.
- 2) The slave station checks that the station No. in the received message matches with the own station No. or not.
- 3) If matched, the slave station executes the command and sends back the response message.
- 4) If mismatched, the slave station leaves the command message and wait for the next command message.

- a) In case when the station No. in the received command message matches with the own slave station No.

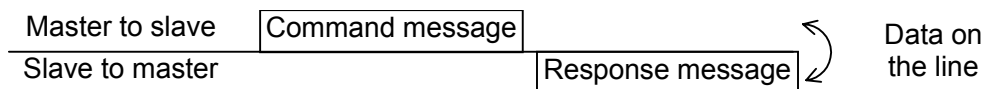

- b) In case when the station No. in the received command message mismatches with the own slave station No.

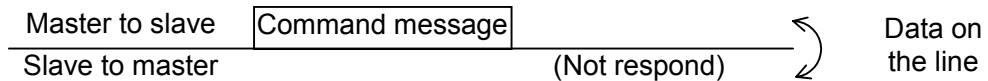

The master station can individually communicate with any one of slave stations connected on the same line upon setting the station No. in the command message.

5.2 Composition of message

Command message and response message consist of 4 fields ; Station No., Function code, Data and Error check code. And these are send in this order.

Station No. (1 byte)
Function code (1 byte)
Data (2 to 133 bytes)
Error check code (CRC-16) (2 bytes)

Fig. 5-1 Composition of message

In the following, each field is explained.

(1) Station No.

Station No. is the number specifying a slave station. Only a slave station that corresponds to a value to which "Station No." is set on the analyzer maintenance mode display executes a command.

(2) Function code

This is a code to designate the function executed at a slave station.
For details, refer to section 5.4.

(3) Data

Data are the data required for executing function codes. The composition of data varies with function codes. For details, refer to chapter 6.

A register number is assigned to each data in the analyzer. For reading/writing the data by communication, designate the register number.

Note that the register number transmitted on message is expressed as its relative address.
The relative address is calculated by the following expression.

$$\boxed{\text{Relative address}} = \left(\text{The lower 4 digits of the } \boxed{\text{Register number}} \right) - 1$$

For example, when the register number designated by a function code is 40003,

$$\begin{aligned} \text{Relative address} &= (\text{lower 4 digits of } 40003) - 1 \\ &= 0002 \end{aligned}$$

is used on the message.

(4) Error check code

This is the code to detect message errors (change in bit) in the signal transmission.
On the MODBUS protocol (RTU mode), CRC-16 (Cyclic Redundancy Check) is applied.
For CRC calculation method, refer to section 5.5.

5.3 Response of slave station

(1) Response for normal command

To a relevant message, the slave station creates and sends back a response message which corresponds to the command message. The composition of message in this case is the same as in section 5.2.

Contents of the data field depend on the function code. For details, refer to Chapter 6.

(2) Response for abnormal command

If contents of a command message have an abnormality (for example, non-actual function code is designated) other than transmission error, the slave station does not execute that command but creates and sends back a response message at error detection.

The composition of response message at error detection is as shown in Fig. 5-2. The value used for function code field is function code of command message plus 80_H.

Table 5-1 gives error codes.

Station No.
Function code + 80 _H
Error code
Error check (CRC-16)

Fig. 5-2 Response message at error detection

Table 5-1 Error code

Error code	Contents	Description
01H	Illegal function	Non-actual function code is designated. Check for the function code.
02H	Illegal data address	A relative address of a register number to which the designated function code can not be used.
03H	Illegal data value	Because the designation of number is too much, the area where register numbers do not exist is designated.

(3) No response

Under any of the following items, the slave station takes no action of the command message and sends back no response.

- A station number transmitted in the command message differs from the station number specified to the slave station.
- A error check code is not matched, or a transmission error (parity error, etc.) is detected.
- The time interval between the composition data of the message becomes longer than the time corresponding to 24 bits. (Refer to section 5.6 Transmission control procedure)

5.4 Function code

According to MODBUS protocol, register numbers are assigned by function codes.
Each function code acts on specific register number.

This correspondence is shown in Table 5-2, and the message length by function is shown in Table 5-3.

Table 5-2 Correspondence between function codes and objective address

Function code			Resister No.	
No.	Function	Object	No.	Contents
03 _H	Read-out (continuously)	Holding register	4xxxx	Read-out/write-in word data
04 _H	Read-out (continuously)	Input register	3xxxx	Read-out word data
06 _H	Write-in	Holding register	4xxxx	Read-out/write-in word data
10 _H	Write-in (continuously)	Holding register	4xxxx	Read-out/write-in word data

Table 5-3 Function code and message length

[Unit : byte]

Function code	Contents	Number of designatable data	Command message		Response message	
			Minimum	Maximum	Minimum	Maximum
03 _H	Read-out of word data	64 words	8	8	7	133
04 _H	Read-out of word data (read-out only)	64 words	8	8	7	133
06 _H	Write-in of word data	1 word	8	8	8	8
10 _H	Write-in of continuous word data	64 words	11	137	8	8

5.5 Calculation of error check code (CRC-16)

CRC-16 is the 2-byte (16-bits) error check code. From the top of the message (station No.) to the end of the data field are calculated.

The slave station calculates the CRC of the received message, and does not respond if the calculated CRC is different from the contents of the received CRC code.

The following shows the calculation procedure for CRC-16.

- (a) Store $FFFF_H$ into 16 bit register (CRC register).
- (b) Subject the 1st byte (8 bits) of transmit message and CRC register contents to an exclusive logical summation (XOR), and store the result into the CRC register.
- (c) Shift the CRC register contents 1 bit to the right. Store 0 at MSB.
- (d) If LSB before shifting is 0, do nothing.
If LSB before shifting is 1, subject it and $A001H$ to XOR, and store the result into the CRC register.
- (e) Repeat the steps (c) and (d) 8 times (shift by 8 bits).
- (f) Execute steps (b) to (e) for the next byte of the transmit message.
Likewise, successively repeat the steps to each byte of the transmit message.
- (g) The CRC code that is retained is the value of CRC register that stands when the processing has ended for latest byte (latest data except error code) of the transmit message.
- (h) As error check code of the transmit message, store this CRC value in the order of lower 8 bits and upper 8 bits.

Transmit message (ex.)

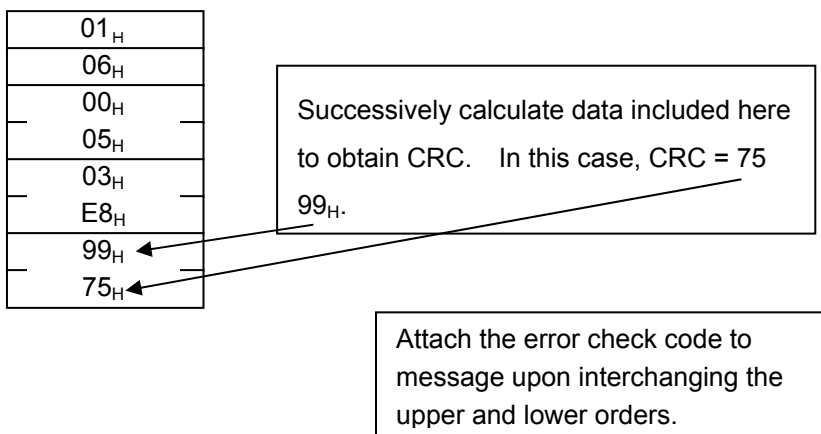

Fig. 5-3 shows the flow of the CRC-16 calculation system.

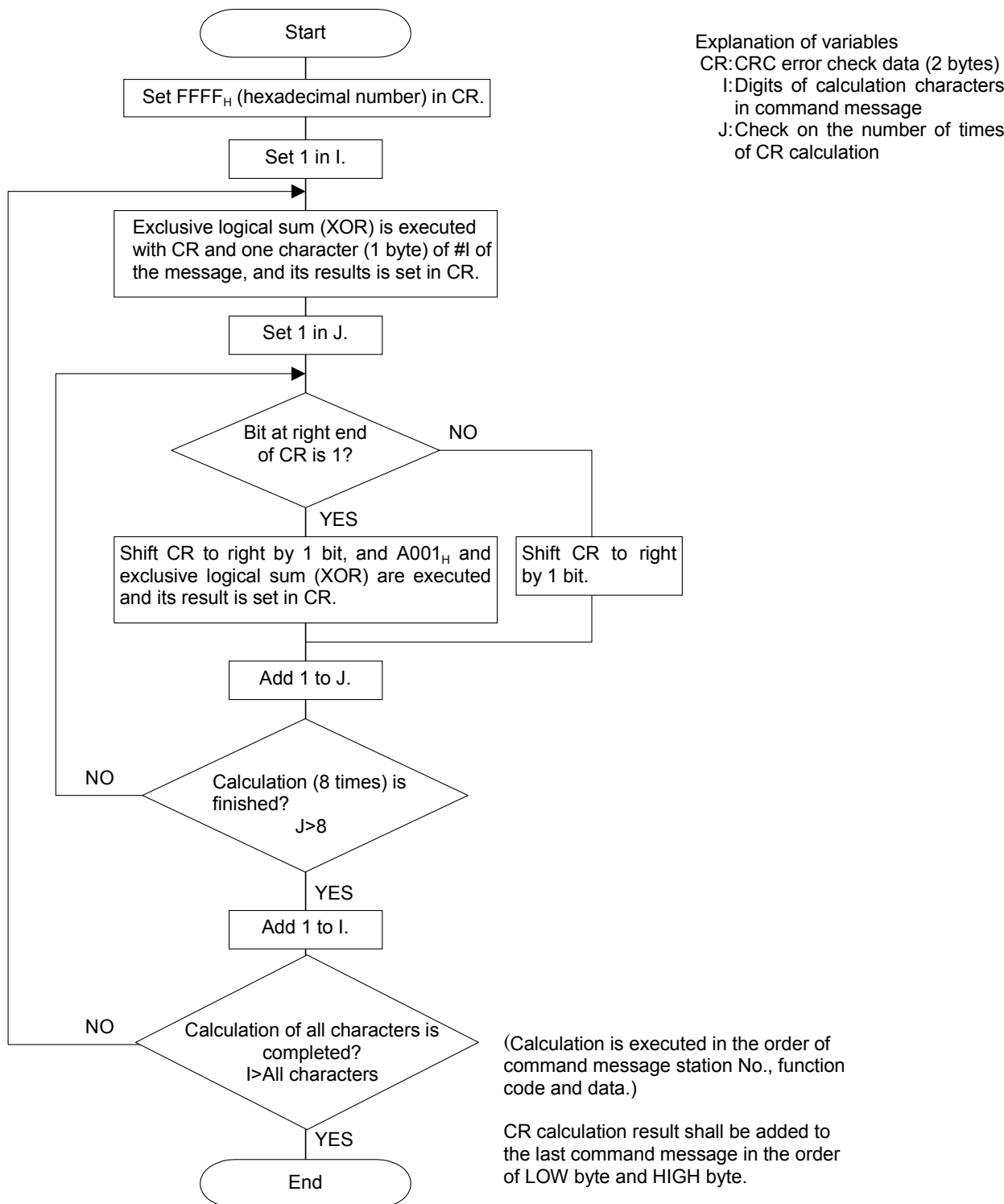

Fig. 5-3 Flow of CRC-16 calculation

5.6 Transmission control procedure

(1) Transmission procedure of master station

The master station must proceed to a communication upon conforming to the following items.

- (1-1) Before sending a command message, provide 48 bits time or more vacant status.
- (1-2) For sending, the interval between bytes of a command message is below 24 bits time.
- (1-3) Within 24 bits time after sending a command message, the receiving status is posted.
- (1-4) Provide 48 bits time or more vacant status between the end of response message reception and beginning of next command message sending [same as in (1-1)].
- (1-5) For ensuring the safety, make a confirmation of the response message and make an arrangement so as to provide 3 times or more retries in case of no response, error occurrence, etc.

Note) The above definition is for most unfavorable value. For ensuring the safety, it's recommended the program of the master to work with safety factors of 2 to 3. Concretely, it is advised to arrange the program for 38400 bps with 5 ms or more for vacant status (1-1), and within 1 ms for byte interval (1-2) and changeover from sending to receiving (1-3).

(2) Description

1) Detection of the message frame

The status on the line of the communication system is one of the 2 below.

- (a) Vacant status (no data on line)
- (b) Communication status (data is existing)

Instruments connected on the line are initially at a receiving status and monitoring the line. When 24 bits time or more vacant status has appeared on the line, the end of preceding frame is assumed and, within following 24 bits time, a receiving status is posted. When data appears on the line, instruments receive it while 24 bits time or more vacant status is detected again, and the end of that frame is assumed. I.e., data which appeared on the line from the first 24 bits time or more vacant status to the next 24 bits time or more vacant status is fetched as one frame.

Therefore, one frame (command message) must be sent upon confirming the following.

- (1-1) 48 bits time or more vacant status precedes before the command message sending.
- (1-2) Interval between bytes of 1 command message is smaller than 24 bits time.

2) Response of this instrument

After a frame detection (24 bits time or more vacant status), this instrument carries out processing with that frame as a command message. If the command message is destined to the own station, a response message is returned. Its processing time is 1 to 30 ms (depends on contents of command message). After sending a command message, therefore, the master station must observe the following.

- (1-3) Receiving status is posted within 24 bits time after sending a command message.

Space time of longer than 2.5ms is needed
(longer than 5ms is recommended)

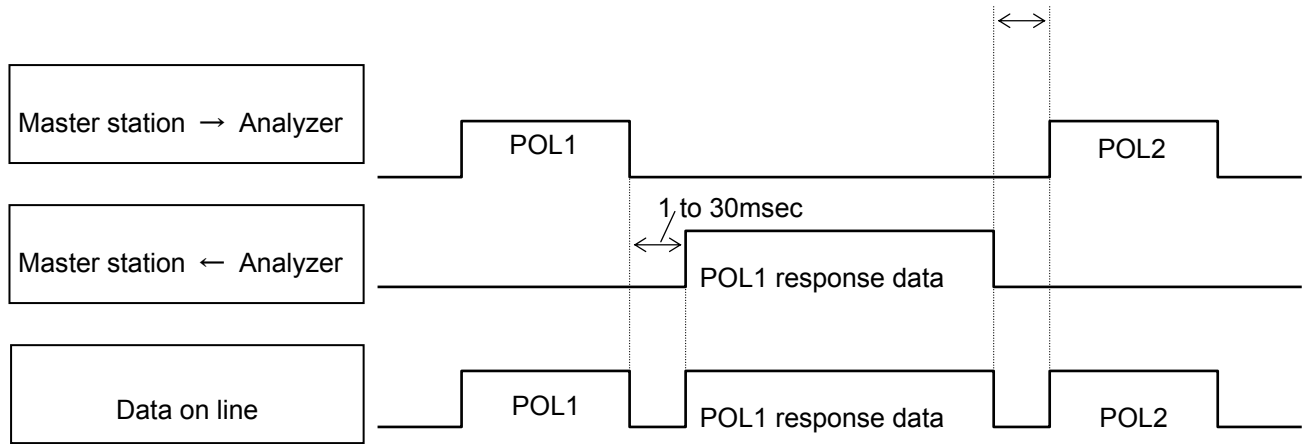

6. DETAILS OF MESSAGE

6.1 Read-out of word data [Function code:03_H]

Function code	Max. word number read-out in one message	Relative data address	Register No.	Contents
03 _H	64 words	0000 _H —009D _H	40001—40158	User setting

(1) Message composition

Command message composition (byte)

Station No.	
Function code	
Read-out start No. (relative address)	Upper
	Lower
Read-out word number	Upper
	Lower
CRC data	Lower
	Upper

} 1 to 64

Response message composition (byte)

Station No.	
Function code	
Read-out byte number	
Contents of the first word data	Upper
	Lower
Contents of the next word data	Upper
	Lower
Contents of the last word data	Upper
	Lower
CRC data	Lower
	Upper

Read-out word number × 2

* Arrangement of read-out word data

MSB	LSB
Upper byte of contents of the first word data	
Lower byte of contents of the first word data	
Upper byte of contents of the next word data	
Lower byte of contents of the next word data	
Upper byte of contents of the last word data	
Lower byte of contents of the last word data	

(2) Function explanations

Word data of continuous word numbers from the read-out start No. can be read. Read-out word data are transmitted from the slave station in the order of upper and lower bytes.

(3) Message transmission (example)

The following shows an example of reading out from No. 1 station the setting Ch2 (2nd component) range-1 zero and span calibration concentration.

Relative address of Ch2 range-1 zero calibration concentration setting: 0004_H Data number: 02_H

Command message composition (byte)

Station No.	01 _H	
Function code	03 _H	
Read-out start No. (relative address)	Upper	00 _H
	Lower	04 _H
Read-out word number	Upper	00 _H
	Lower	02 _H
CRC data	Lower	85 _H
	Upper	CA _H

Response message composition (byte)

Station No.	01 _H	
Function code	03 _H	
Read-out byte number	04 _H	
Contents of the first word data	Upper	00 _H
	Lower	00 _H
Contents of the next word data	Upper	03 _H
	Lower	E8 _H
CRC data	Lower	FA _H
	Upper	8D _H

* Meaning of read-out data

Ch2 range-1 zero calibration concentration setting 00 00_H = 0
(contents of first word data)

Ch2 range-1 span calibration concentration setting 03 E8_H = 1000
(contents of next word data)

Provided decimal point position = 1, measurement unit = 1,
Ch2 range-1 zero calibration concentration setting = 0.0 ppm
Ch2 range-1 span calibration concentration setting = 100.0 ppm

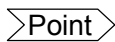

For handling of decimal point and unit, refer to Section 7.1.

6.2 Read-out of read only word data [Function code:04_H]

Function code	Max. word number read-out in one message	Relative data address	Resister No.	Contents
04 _H	64 words	0000 _H —00C1 _H	30001—30194	Measurement value and status
		0425 _H —0469 _H	31062—31130	Fixed setting

(1) Message composition

Command message composition (byte)

Station No.	
Function code	
Read-out start No. (relative address)	Upper
	Lower
Read-out word number	Upper
	Lower
CRC data	Lower
	Upper

Response message composition (byte)

Station No.		Read-out word number × 2
Function code		
Read-out byte number		
Contents of the first word data	Upper	
	Lower	
Contents of the next word data	Upper	
	Lower	
—		
Contents of the last word data	Upper	
	Lower	
CRC data	Lower	
	Upper	

* Arrangement of read-out word data

MSB	LSB
Upper byte of contents of the first word data	
Lower byte of contents of the first word data	
Upper byte of contents of the next word data	
Lower byte of contents of the next word data	
—	
Upper byte of contents of the last word data	
Lower byte of contents of the last word data	

(2) Function explanations

Word data of continuous word numbers from the read-out start No. can be read. Read-out word data are transmitted from the slave station in the order of upper and lower bytes.

(3) Message transmission (example)

The following shows an example of reading out from No. 1 station the Ch5 measurement concentration, decimal point position and measurement unit.

Relative address of Ch5 measurement concentration: 000C_H Data number: 03_H

Command message composition (byte)

Station No.		01 _H
Function code		04 _H
Read-out start No. (relative address)	Upper	00 _H
	Lower	0C _H
Read-out word number	Upper	00 _H
	Lower	03 _H
CRC data	Lower	70 _H
	Upper	08 _H

Response message composition (byte)

Station No.		01 _H
Function code		04 _H
Read-out byte number		06 _H
Contents of the first word data	Upper	04 _H
	Lower	B0 _H
Next word data contents	Upper	00 _H
	Lower	02 _H
Latest word data contents	Upper	00 _H
	Lower	00 _H
CRC data	Lower	81 _H
	Upper	0D _H

* Meaning of read-out data

First word data contents 04 B0_H = 1200
 Next word data contents 00 02_H = 2 (decimal point position)
 Latest word data contents 00 00_H = 0 (vol %)

In the above case, measurement concentration = 12.00 vol%



For handling of decimal point and unit, refer to Section 7.1.

6.3 Write-in of word data (1 word) [Function code:06_H]

Function code	Max. word number write-in in one message	Relative data address	Resister No.	Contents
06 _H	1 word	0000 _H —009D _H	40001—40158	User setting
		07D0 _H —07D4 _H	42001—42005	Operation command

(1) Message composition

Command message composition (byte)

Station No.	
Function code	
Write-in designate No. (relative address)	Upper
	Lower
Write-in word data	Upper
	Lower
CRC data	Lower
	Upper

Response message composition (byte)

Station No.	
Function code	
Write-in designate No. (relative address)	Upper
	Lower
Write-in word data	Upper
	Lower
CRC data	Lower
	Upper

(2) Function explanation

Designated word data is written in write-in designate No. Write-in data are transmitted from master station in the order of upper and lower bytes.

(3) Message transmission (example)

The following shows an example of transmitting the "ZERO" key command to No. 1 station.
Key operation command Relative address: 07D0_H

Command message composition (byte)

Station No.	01 _H	
Function code	06 _H	
Write-in designate No. (relative address)	Upper	07 _H
	Lower	D0 _H
Write-in word data	Upper	00 _H
	Lower	40 _H
CRC data	Lower	88 _H
	Upper	B7 _H

} ZERO key command

Response message composition (byte)

Station No.	01 _H	
Function code	06 _H	
Write-in designate No. (relative address)	Upper	07 _H
	Lower	D0 _H
Write-in word data	Upper	00 _H
	Lower	40 _H
CRC data	Lower	88 _H
	Upper	B7 _H

6.4 Write-in of continuous word data [Function code:10_H]

Function code	Max. word number write-in in one message	Relative data address	Resister No.	Kind of data
10 _H	64 words	0000 _H —009D _H	40001—40158	User setting

(1) Message composition

Command message composition (byte)

Station No.	
Function code	
Write-in start No. (relative address)	Upper
	Lower
Write-in word number	Upper
	Lower
Write-in byte number	
First write-in word data	Upper
	Lower
Next write-in word data	Upper
	Lower
Last write-in word data	Upper
	Lower
CRC data	Lower
	Upper

} 1 to 64

} Write-in word number × 2

Response message composition (byte)

Station No.	
Function code	
Write-in start No. (relative address)	Upper
	Lower
Write-in word number	Upper
	Lower
CRC data	Lower
	Upper

* Arrangement of write-in word data

MSB	LSB
Upper byte of contents of the first word data	
Lower byte of contents of the first word data	
Upper byte of contents of the next word data	
Lower byte of contents of the next word data	
Upper byte of contents of the last word data	
Lower byte of contents of the last word data	

(2) Function explanation

Word data of continuous word number is written from write-in start address. Write-in word data are transmitted from master station in the order of upper and lower bytes.

7. ADDRESS MAP AND DATA FORMAT

7.1 Data format

7.1.1 Transmission data format

The MODBUS protocol used in this instrument is RTU (Remote Terminal Unit) mode. Transmitted data is "numeric value" and not ASCII code".

7.1.2 Handling of decimal point position and measurement unit

When transmitted, the calibration concentration setting, alarm's high and low limits, the data of measurement concentration value and range value have no decimal point nor measurement unit.

Calculate exact values of data upon point positioning as shown below.

- (a) Calibration concentration setting (register No. 40001 to 40020)
 - Alarm setting (register No. 40036 to 40055)
 - Range value (register No. 31077 to 31086)

You can know the point position for each Ch (channel) and each range, and unit upon reading in the decimal point position data (register No. 31087 to 31096), and the unit data (register No. 31067 to 31076).

The decimal point position data has a value of 0, 1, 2 or 3. You can obtain an exact value by the following calculation.

- Case 0: Calibration concentration setting data /1
- Case 1: Calibration concentration setting data /10
- Case 2: Calibration concentration setting data /100
- Case 3: Calibration concentration setting data /1000

The unit data has a value of 0, 1, 2 or 3, that corresponds as follows.

- Case 0: vol%
- Case 1: ppm
- Case 2: mg/m³
- Case 3: g/m³

For example, if:

- Ch1 range-1 span calibration concentration setting (register No. 40002) = 2000,
- Ch1 range-1 decimal point position (register No. 31087) = 1, and
- Ch1 range-1 unit (register No. 31067) = 1,

the value is 200.0 ppm.

For writing-in, proceed in the reverse. To obtain 200.0 ppm, write 2000 as calibration concentration setting.

The decimal point position and unit are unchangeable because fixed to each Ch and each range.

(b) Measurement concentration (register No. 30001 to 30036)

The decimal point position and measurement unit for each concentration are stored in registers following that of concentration, and can be known by reading them in.

The meaning of decimal point position data and measurement unit data values are the same as in (a) above.

For example, if:

Ch3 measurement concentration (register No. 30007) = 1270,

Ch3 decimal point position (register No. 30008) = 2,

Ch3 measurement unit (register No. 30009) = 0,

the value is 12.70 vol%

7.1.3 Handling at measurement data over-range

Even if the measurement data is at over-range, with "— — — —" displayed on the screen, the concentration that stands then is transmitted as read-out measurement concentration.

7.2 Address map

For details of functions and settable ranges of different parameters, refer to the instruction manual for the analyzer.

Word data [read-out/write-in]: Function code [03_H, 06_H, 10_H]

User settings

Relative address	Register No.	Data type	Memory contents	Read-out/write-in data	Remarks or corresponding parameter
0000 _H	40001	Word	Ch1 range-1 zero calibration concentration	0 to 9999	Calibration value
0001 _H	40002	Word	Ch1 range-1 span calibration concentration	Decimal point position depends on range	
0002 _H	40003	Word	Ch1 range-2 zero calibration concentration		
0003 _H	40004	Word	Ch1 range-2span calibration concentration		
0004 _H	40005	Word	Ch2 range-1zero calibration concentration		
0005 _H	40006	Word	Ch2 range-1 span calibration concentration		
0006 _H	40007	Word	Ch2 range-2 zero calibration concentration		
0007 _H	40008	Word	Ch2 range-2 span calibration concentration		
0008 _H	40009	Word	Ch3 range-1 zero calibration concentration		
0009 _H	40010	Word	Ch3 range-1 span calibration concentration		
000A _H	40011	Word	Ch3 range-2 zero calibration concentration		
000B _H	40012	Word	Ch3 range-2 span calibration concentration		
000C _H	40013	Word	Ch4 range-1 zero calibration concentration		
000D _H	40014	Word	Ch4 range-1 span calibration concentration		
000E _H	40015	Word	Ch4 range-2 zero calibration concentration		
000F _H	40016	Word	Ch4 range-2 span calibration concentration		
0010 _H	40017	Word	Ch5 range-1 zero calibration concentration		
0011 _H	40018	Word	Ch5 range-1 span calibration concentration		
0012 _H	40019	Word	Ch5 range-2zero calibration concentration		
0013 _H	40020	Word	Ch5 range-2 span calibration concentration		

Word data [read-out/write-in]: Function code [03_H, 06_H, 10_H]

User settings

Relative address	Register No.	Data type	Memory contents	Read-out/write-in data	Remarks or corresponding parameter
0014 _H	40021	Word	Ch1 auto calibration switch	0, 1	Auto calibration component
0015 _H	40022	Word	Ch2 auto calibration switch	(0: Do not calibrate in auto calibration 1: Calibrate in auto calibration)	
0016 _H	40023	Word	Ch3 auto calibration switch		
0017 _H	40024	Word	Ch4 auto calibration switch		
0018 _H	40025	Word	Ch5 auto calibration switch		
0019 _H	40026	Word	Ch1 zero calibration switch		0,1
001A _H	40027	Word	Ch2 zero calibration switch	(0: Selectable zero calibration, 1: Zero calibration at once)	
001B _H	40028	Word	Ch3 zero calibration switch		
001C _H	40029	Word	Ch4 zero calibration switch		
001D _H	40030	Word	Ch5 zero calibration switch		
001E _H	40031	Word	Ch1 calibration range switch		0,1
001F _H	40032	Word	Ch2 calibration range switch	(0: Calibrate indicated range only, 1: Calibrate both ranges at same time)	
0020 _H	40033	Word	Ch3 calibration range switch		
0021 _H	40034	Word	Ch4 calibration range switch		
0022 _H	40035	Word	Ch5 calibration range switch		
0023 _H	40036	Word	Ch1 range-1 high alarm setting		0 to 9999
0024 _H	40037	Word	Ch1 range-1 low alarm setting	Decimal point position depends on range	
0025 _H	40038	Word	Ch1 range-2 high alarm setting		
0026 _H	40039	Word	Ch1 range-2 low alarm setting		
0027 _H	40040	Word	Ch2 range-1 high alarm setting		
0028 _H	40041	Word	Ch2 range-1 low alarm setting		
0029 _H	40042	Word	Ch2 range-2 high alarm setting		
002A _H	40043	Word	Ch2 range-2 low alarm setting		
002B _H	40044	Word	Ch3 range-1 high alarm setting		
002C _H	40045	Word	Ch3 range-1 low alarm setting		
002D _H	40046	Word	Ch3 range-2 high alarm setting		
002E _H	40047	Word	Ch3 range-2 low alarm setting		
002F _H	40048	Word	Ch4 range-1 high alarm setting		
0030 _H	40049	Word	Ch4 range-1 low alarm setting		
0031 _H	40050	Word	Ch4 range-2 high alarm setting		
0032 _H	40051	Word	Ch4 range-2 low alarm setting		
0033 _H	40052	Word	Ch5 range-1 high alarm setting		
0034 _H	40053	Word	Ch5 range-1 low alarm setting		
0035 _H	40054	Word	Ch5 range-2 high alarm setting		
0036 _H	40055	Word	Ch5 range-2 low alarm setting		

Word data [read-out/write-in]: Function code [03_H, 06_H, 10_H]

User settings

Relative address	Register No.	Data type	Memory contents	Read-out/write-in data	Remarks or corresponding parameter
0037 _H	40056	Word	Ch1 alarm mode	0,1,2,3,4 (0: High limit alarm, 1: Low limit alarm, 2: High or low limit) 3: High-high limit alarm, 4: Low-low limit alarm	Alarm setting
0038 _H	40057	Word	Ch2 alarm mode		
0039 _H	40058	Word	Ch3 alarm mode		
003A _H	40059	Word	Ch4 alarm mode		
003B _H	40060	Word	Ch5 alarm mode		
003C _H	40061	Word	Ch1 alarm switch	0,1 (0: Alarm OFF, 1: Alarm ON)	
003D _H	40062	Word	Ch2 alarm switch		
003E _H	40063	Word	Ch3 alarm switch		
003F _H	40064	Word	Ch4 alarm switch		
0040 _H	40065	Word	Ch5 alarm switch		
0041 _H	40066	Word	Alarm hysteresis	0000H to 0014H (0 to 20%FS)	
0042 _H	40067	Word	Auto calibration start time(day)	00H to 06H (Sun. to Sat.)	Setting of auto calibration (option)
0043 _H	40068	Word	Auto calibration start time(hour)	00H to 23H (BCD code)	
0044 _H	40069	Word	Auto calibration start time(min)	00H to 59H (BCD code)	
0045 _H	40070	Word	Auto calibration cycle		
0046 _H	40071	Word	Auto calibration cycle unit	0,1 (0: h, 1: days)	
0047 _H	40072	Word	Auto calibration switch	0,1 (0: OFF, 1: ON)	
0048 _H	40073		Not used		
0049 _H	40074	Word	Key lock switch	0,1 (0: OFF, 1: ON)	Key lock
004A _H	40075		Not used		
004B _H	40076	Word	Ch1 response time	0000H to 003Ch (0 to 60 sec)	Response time The response time of O ₂ measurement defines register No 40084, regardless of measurement Ch
004C _H	40077	Word	Not used		
004D _H	40078	Word	Ch2 response time		
004E _H	40079	Word	Not used		
004F _H	40080	Word	Ch3 response time		
0050 _H	40081	Word	Not used		
0051 _H	40082	Word	Ch4 response time		
0052 _H	40083	Word	Not used		
0053 _H	40084	Word	O ₂ meter response time		
0054 _H	40085	Word	1st order moving average period	0000H to 003bH (0 to 59 min or 1 to 4 h)	Average period (option)
0055 _H	40086	Word	2nd order moving average period		
0056 _H	40087	Word	3rd order moving average period		
0057 _H	40088	Word	4th order moving average period		
0058 _H	40089	Word	1st order moving average period unit	0,1 (0: h, 1: min)	
0059 _H	40090	Word	2nd order moving average period unit		
005A _H	40091	Word	3rd order moving average period unit		
005B _H	40092	Word	4th order moving average period unit		

Word data [read-out/write-in]: Function code [03_H, 06_H, 10_H]

User settings

Relative address	Register No.	Data type	Memory contents	Read-out/write-in data	Remarks or corresponding parameter
005C _H	40093	Word	Hold switch	0,1 (0: OFF, 1: ON)	Output hold
005D _H	40094	Word	Oxygen conversion reference value	01H to 13H(1% to 19%)	Oxygen conversion reference value
005E _H	40095	Word	Peak alarm switch	0,1 (0: OFF, 1: ON)	Setting of peak alarm
005F _H	40096	Word	Peak alarm concentration	0064H to 03e8H (100 to 1000ppm)	
0060 _H	40097	Word	Peak alarm count	0001H to 0063H (1 to 99 times)	
0061 _H	40098	Word	Peak alarm hysteresis	0000H to 0014H (0 to 20%FS)	
0062 _H	40099	Word	Auto zero calibration start (day)	00H to 06H (Sun. to Sat.)	Setting of auto zero calibration (option)
0063 _H	40100	Word	Auto zero calibration start (hour)	00H to 23H (BCD code)	
0064 _H	40101	Word	Auto zero calibration start (min)	00H to 59H (BCD code)	
0065 _H	40102	Word	Auto zero calibration cycle		
0066 _H	40103	Word	Auto zero calibration cycle unit	0,1 (0: h, 1: days)	
0067 _H	40104	Word	Auto zero calibration switch	0,1 (0: OFF, 1: ON)	
0068 _H	40105	Word	Auto zero calibration gas flow time	003Ch to 0384H (60 to 900 sec)	
0069 _H	40106	Word	Ch1 range change setting	0,1 (0: range-1, 1: range-2)	Range changeover (disabled if remote range ON)
006A _H	40107	Word	Ch2 range change setting		
006B _H	40108	Word	Ch3 range change setting		
006C _H	40109	Word	Ch4 range change setting		
006D _H	40110	Word	Ch5 range change setting		
006E _H	40111	Word	Ch1 range change method	0,1,2 (0:manual, 1:remote, 2:auto)	
006F _H	40112	Word	Ch2 range change method		
0070 _H	40113	Word	Ch3 range change method		
0071 _H	40114	Word	Ch4 range change method		
0072 _H	40115	Word	Ch5 range change method		
0073 _H	40116	Word	Ch1 auto calibration range	0,1 (0:range-1, 1:range-2)	
0074 _H	40117	Word	Ch2 auto calibration range		
0075 _H	40118	Word	Ch3 auto calibration range		
0076 _H	40119	Word	Ch4 auto calibration range		
0077 _H	40120	Word	Ch5 auto calibration range		
0078 _H	40121	Word	Alarm 1 target channel	0,1,2,3,4,5,6	
0079 _H	40122	Word	Alarm 2 target channel		
007A _H	40123	Word	Alarm 3 target channel		
007B _H	40124	Word	Alarm 4 target channel		
007C _H	40125	Word	Alarm 5 target channel		
007D _H	40126	Word	Alarm 6 target channel		
007E _H	40127	Word	alarm-6 range-1 high alarm setting	0 to 9999 Decimal point position depends on range	Alarm-6 setting (option)
007F _H	40128	Word	alarm-6 range-1 low alarm setting		
0080 _H	40129	Word	alarm-6 range-2 high alarm setting		
0081 _H	40130	Word	alarm-6 range-2 low alarm setting		

Word data [read-out/write-in]: Function code [03_H, 06_H, 10_H]

User settings

Relative address	Register No.	Data type	Memory contents	Read-out/write-in data	Remarks or corresponding parameter
0082 _H	40131	Word	alarm-6 alarm mode	same as alarm Ch1 to 5	
0083 _H	40132	Word	alarm-6 alarm switch	same as alarm Ch1 to 5	
0084 _H	40133	Word	auto calibration gas flow time 1	003Ch to 0384H (60 to 900 sec)	
0085 _H	40134	Word	auto calibration gas flow time 2		
0086 _H	40135	Word	auto calibration gas flow time 3		
0087 _H	40136	Word	auto calibration gas flow time 4		
0088 _H	40137	Word	auto calibration gas flow time 5		
0089 _H	40138	Word	auto calibration gas flow time 6		
008A _H	40139	Word	auto calibration gas flow time 7		
008B _H	40140	Word	Hold change	(0: Last value, 1: Setting)	
008C _H	40141	Word	Ch1 hold set value	0 to 100 (%FS)	
008D _H	40142	Word	Ch2 hold set value		
008E _H	40143	Word	Ch3 hold set value		
008F _H	40144	Word	Ch4 hold set value		
0090 _H	40145	Word	Ch5 hold set value		
0091 _H	40146	Word	Blowback start (day)	00H to 06H (Sun. to Sat.)	Blowback setting (Option)
0092 _H	40147	Word	Blowback start (hour)	00H to 23H (BCD code)	
0093 _H	40148	Word	Blowback start (min)	00H to 59H (BCD code)	
0094 _H	40149	Word	Blowback cycle	1 to 99 (h), 1 to 7 (days)	
0095 _H	40150	Word	Blowback cycle unit	0,1 (0:h, 1:days)	
0096 _H	40151	Word	Blowback time	0001H to 0384H (1 to 900 sec)	
0097 _H	40152	Word	Blowback switch	0,1 (0:OFF, 1:ON)	
0098 _H	40153	Word	Gas displacement time after blowback	003Ch to 0384H (60 to 900 sec)	
0099 _H	40154	Word	Measurement point change cycle	1 to 60 (min), 1 to 99 (h)	Measurement point change setting (Option)
009A _H	40155	Word	Measurement point change cycle unit	0,1 (0: h, 1: min)	
009B _H	40156	Word	Measurement point change displacement time	003Ch to 0384H (60 to 900 sec)	
009C _H	40157	Word	Measurement point change setting	0,1,2 (0: Line, 1: Line 2, 2: Change)	
009D _H	40158	Word	O ₂ concentration limit at the time of oxygen correction	01H to 14H (1 to 20%)	

Word data [write-in] : Function code [06_H]**Operation command**

Relative address	Register No.	Data type	Memory contents	Write-in data	Remarks or corresponding parameter
07D0 _H	42001	Word	Keying command	01H:MODE 02H: Side, 04H: Up, 08H: Down 10H: ESC、20H: ENT 40H: ZERO、80H: SPAN	Sending a value simulates keying
07D1 _H	42002	Word	Display change	1: Return to measurement mode display	Force to return to measurement mode
07D2 _H	42003	Word	Auto calibration	1; Execute auto calibration	Auto calibration is executed only once.
07D3 _H	42004	Word	Auto zero calibration	1; Execute auto zero calibration	Auto zero calibration is executed only once.
07D4 _H	42005	Word	Blowback	1; Execute blowback	Blowback is executed only once. (Option)

Word data [read-out only] : Function code[04 H]

Measurement value and status

Relative address	Register No.	Data type	Memory contents	Read-out data	Remarks or corresponding parameter
0000 _H	30001	Word	Ch1 concentration	Concentration: -9999 to 9999 (value corresponding to indication without decimal point) Decimal point position: 0,1,2,3 (0; concentration/1 1; concentration/10 2; concentration/100 3; concentration/1000) Measurement unit: 0, 1, 2, 3 (0; vol% 1; ppm 2; mg/m ³ 3; g/m ³) Transmit values under current measurement conditions	
0001 _H	30002	Word	Ch1 decimal point position		
0002 _H	30003	Word	Ch1 measurement unit		
0003 _H	30004	Word	Ch2 concentration		
0004 _H	30005	Word	Ch2 decimal point position		
0005 _H	30006	Word	Ch2 measurement unit		
0006 _H	30007	Word	Ch3 concentration		
0007 _H	30008	Word	Ch3 decimal point position		
0008 _H	30009	Word	Ch3 measurement unit		
0009 _H	30010	Word	Ch4 concentration		
000A _H	30011	Word	Ch4 decimal point position		
000B _H	30012	Word	Ch4 measurement unit		
000C _H	30013	Word	Ch5 concentration		
000D _H	30014	Word	Ch5 decimal point position		
000E _H	30015	Word	Ch5 measurement unit		
000F _H	30016	Word	Ch6 concentration		
0010 _H	30017	Word	Ch6 decimal point position		
0011 _H	30018	Word	Ch6 measurement unit		
0012 _H	30019	Word	Ch7 concentration		
0013 _H	30020	Word	Ch7 decimal point position		
0014 _H	30021	Word	Ch7 measurement unit		
0015 _H	30022	Word	Ch8 concentration		
0016 _H	30023	Word	Ch8 decimal point position		
0017 _H	30024	Word	Ch8 measurement unit		
0018 _H	30025	Word	Ch9 concentration		
0019 _H	30026	Word	Ch9 decimal point position		
001A _H	30027	Word	Ch9 measurement unit		
001B _H	30028	Word	Ch10 concentration		
001C _H	30029	Word	Ch10 decimal point position		
001D _H	30030	Word	Ch10 measurement unit		
001E _H	30031	Word	Ch11 concentration		
001F _H	30032	Word	Ch11 decimal point position		
0020 _H	30033	Word	Ch11 measurement unit		
0021 _H	30034	Word	Ch12 concentration		
0022 _H	30035	Word	Ch12 decimal point position		
0023 _H	30036	Word	Ch12 measurement unit		

Word data [read-out only] : Function code[04_H]

Measurement value and status

Relative address	Register No.	Data type	Memory contents	Read-out data	Remarks or corresponding parameter
0024 _H	30037	Word	Peak count	0 to 100 times/hour	
0025 _H	30038	Word	Ch1 current range	0, 1 (0; range-1, 1;range-2)	
0026 _H	30039	Word	Ch2 current range		
0027 _H	30040	Word	Ch3 current range		
0028 _H	30041	Word	Ch4 current range		
0029 _H	30042	Word	Ch5 current range		
002A _H	30043	Word	Ch1 high/low limit alarm	0, 1, 2, 3, 4 (0: No alarm, 1: High limit alarm, 2: Low limit alarm 3: High-high limit alarm, 4: Low-low limit alarm)	Whether or how alarm is currently produced.
002B _H	30044	Word	Ch2 high/low limit alarm		
002C _H	30045	Word	Ch3 high/low limit alarm		
002D _H	30046	Word	Ch4 high/low limit alarm		
002E _H	30047	Word	Ch5 high/low limit alarm		
002F _H	30048	Word	Peak count alarm	0,1 (0: No, 1: Yes)	
0030 _H	30049	Word	Auto (Auto zero) calibration in progress	0,1 (0: No, 1: Yes)	
0031 _H	30050	Word	Ch1 zero calibration in progress	0,1 (0: No, 1: Yes)	
0032 _H	30051	Word	Ch2 zero calibration in progress		
0033 _H	30052	Word	Ch3 zero calibration in progress		
0034 _H	30053	Word	Ch4 zero calibration in progress		
0035 _H	30054	Word	Ch5 zero calibration in progress		
0036 _H	30055	Word	Ch1 span calibration in progress		
0037 _H	30056	Word	Ch2 span calibration in progress		
0038 _H	30057	Word	Ch3 span calibration in progress		
0039 _H	30058	Word	Ch4 span calibration in progress		
003A _H	30059	Word	Ch5 span calibration in progress		
003B _H	30060	Word	Instrument error	0,1 (0: No, 1: Yes)	Whether error is produced
003C _H	30061	Word	Calibration error	0,1 (0: No, 1: Yes)	Whether error is produced
003D _H	30062	Word	Latest error No.	-1 to 9 (Error No.-1) * (a) 1 to 31 (date) 0 to 23 (hours) 0 to 59 (min) 0 to 4	Error log contents
003E _H	30063	Word	Latest error DAY		
003F _H	30064	Word	Latest error HOUR		
0040 _H	30065	Word	Latest error MIN		
0041 _H	30066	Word	Latest error TARGET		

Word data [read-out only] : Function code[04_H]

Measurement value and status

Relative address	Register No.	Data type	Memory contents	Read-out data	Remarks or corresponding parameter
0042 _H	30067	Word	The previous error No.	-1 to 9 (Error No.-1)	
0043 _H	30068	Word	The previous error DAY	1 to 31 (date)	
0044 _H	30069	Word	The previous error HOUR	0 to 23 (hours)	
0045 _H	30070	Word	The previous error MIN	0 to 59 (min)	
0046 _H	30071	Word	The previous error TARGET	0 to 4	
007E _H	30127	Word	Oldest error No.	-1 to 9 (Error No.-1)	
007F _H	30128	Word	Oldest error DAY	1 to 31 (date)	
0080 _H	30129	Word	Oldest error HOUR	0 to 23 (hour)	
0081 _H	30130	Word	Oldest error MIN	0 to 59 (min)	
0082 _H	30131	Word	Oldest error TARGET	0 to 4	
0083 _H	30132	Word	Error 1	0,1 (0: No, 1: Yes)	Whether error is currently produced
0084 _H	30133	Word	Error 2		
0085 _H	30134	Word	Error 3		
0086 _H	30135	Word	Error 10		
0087 _H	30136	Word	Ch1 Error 4	0,1 (0: No, 1: Yes)	
0088 _H	30137	Word	Ch1 Error 5		
0089 _H	30138	Word	Ch1 Error 6		
008A _H	30139	Word	Ch1 Error 7		
008B _H	30140	Word	Ch1 Error 8		
008C _H	30141	Word	Ch1 Error 9		
0099 _H	30154	Word	Ch4 Error 4	0,1 (0: No, 1: Yes)	
009A _H	30155	Word	Ch4 Error 5		
009B _H	30156	Word	Ch4 Error 6		
009C _H	30157	Word	Ch4 Error 7		
009D _H	30158	Word	Ch4 Error 8		
009E _H	30159	Word	Ch4 Error 9		
009F _H	30160	Word	Ch5 Error 4	0,1 (0: No, 1: Yes)	
00A0 _H	30161	Word	Ch5 Error 5		
00A1 _H	30162	Word	Ch5 Error 6		
00A2 _H	30163	Word	Ch5 Error 7		
00A3 _H	30164	Word	Ch5 Error 8		
00A4 _H	30165	Word	Ch5 Error 9		

Word data [read-out only] : Function code[04_H]

Measurement value and status

Relative address	Register No.	Data type	Memory contents	Read-out data	Remarks or corresponding parameter
00A5 _H	30166	Word	Ch1 auto zero calibration in progress	0,1 (0: No, 1: Yes)	
00A6 _H	30167	Word	Ch1 auto span calibration in progress		
00A7 _H	30168	Word	Ch1 hold in progress	0,1 (0: No, 1: Yes)	
00AE _H	30175	Word	Ch4 auto zero calibration in progress	0,1 (0: No, 1: Yes)	
00AF _H	30176	Word	Ch4 auto span calibration in progress		
00B0 _H	30177	Word	Ch4 hold in progress	0,1 (0: No, 1: Yes)	
00B1 _H	30178	Word	Ch5 auto zero calibration in progress	0,1 (0: No, 1: Yes)	
00B2 _H	30179	Word	Ch5 auto span calibration in progress		
00B3 _H	30180	Word	Ch5 hold in progress	0,1 (0: No, 1: Yes)	
00B4 _H	30181	Word	Display information (1)	* (b)	
00B5 _H	30182	Word	Display information (2)		
00B6 _H	30183	Word	Display information (3)		
00B7 _H	30184		(Do not use)		
00B8 _H	30185		(Do not use)		
00B9 _H	30186		(Do not use)		
00BA _H	30187		(Do not use)		
00BB _H	30188		(Do not use)		
00BC _H	30189	Word	Manual calibration channel	Cursor Ch-1 * (c)	
00BD _H	30190		(Do not use)		
00BE _H	30191	Word	High/Low limit alarm (6)		
00BF _H	30192		(Do not use)		
00C0 _H	30193		(Do not use)		
00C1 _H	30194		(Do not use)		

Word data [read-out only] : Fuction code[04_H]

Fixed setting

Relative address	Register No.	Data type	Memory contents	Read-out data	Remarks or corresponding parameter	
0425 _H	31062	Word	Ch1 range numbers	1, 2		
0426 _H	31063	Word	Ch2 range numbers	(1: 1 range, 2: 2 ranges)		
0427 _H	31064	Word	Ch3 range numbers			
0428 _H	31065	Word	Ch4 range numbers			
0429 _H	31066	Word	Ch5 range numbers			
042A _H	31067	Word	Ch1 range-1 unit	0,1,2,3		
042B _H	31068	Word	Ch1 range-2 unit	(0;vol%		
042C _H	31069	Word	Ch2 range-1 unit	1; ppm		
042D _H	31070	Word	Ch2 range-2 unit	2; mg/m3		
042E _H	31071	Word	Ch3 range-1 unit	3; g/m3)		
042F _H	31072	Word	Ch3 range-2unit			
0430 _H	31073	Word	Ch4 range-1 unit			
0431 _H	31074	Word	Ch4 range-2 unit			
0432 _H	31075	Word	Ch5 range-1 unit			
0433 _H	31076	Word	Ch5 range-2 unit			
0434 _H	31077	Word	Ch1 range-1 value	1 to 9999		The actual range value is calculated with the decimal point position taken into consideration. Actual range value = Read range value / X (X is 1 when 0 is selected, 10 when 1 is selected, and 100 when 2 is selected, and 1000 when 3 is selected for decimal point position.)
0435 _H	31078	Word	Ch1 range-2 value			
0436 _H	31079	Word	Ch2 range-1 value			
0437 _H	31080	Word	Ch2 range-2 value			
0438 _H	31081	Word	Ch3 range-1 value			
0439 _H	31082	Word	Ch3 range-2 value			
043A _H	31083	Word	Ch4 range-1 value			
043B _H	31084	Word	Ch4 range-2 value			
043C _H	31085	Word	Ch5 range-1 value			
043D _H	31086	Word	Ch5 range-2 value			
043E _H	31087	Word	Ch1 range-1 decimal point position	0,1,2,3		
043F _H	31088	Word	Ch1 range-2 decimal point position	(0: Nothing below decimal point, 1: 1 digit below decimal point, 2: 2 digits below decimal point, 3: 3 digits below decimal point.		
0440 _H	31089	Word	Ch2 range-1 decimal point position			
0441 _H	31090	Word	Ch2 range-2 decimal point position			
0442 _H	31091	Word	Ch3 range-1 decimal point position			
0443 _H	31092	Word	Ch3 range-2 decimal point position			
0444 _H	31093	Word	Ch4 range-1 decimal point position			
0445 _H	31094	Word	Ch4 range-2 decimal point position			
0446 _H	31095	Word	Ch5 range-1 decimal point position			
0447 _H	31096	Word	Ch5 range-2 decimal point position			

Word data [read-out only] : Fuction code[04_H]

Fixed setting

Relative address	Register No.	Data type	Memory contents	Read-out data	Remarks or corresponding parameter
0448 _H	31097	Word	Type: 1st digit	Z	
0449 _H	31098	Word	Type: 2nd digit		
044A _H	31099	Word	Type: 3rd digit	E	
044B _H	31100	Word	Type: 4th digit	0 to 9, A to Z	
044C _H	31101	Word	Type: 5th digit	0 to 9, A to Z	
044D _H	31102	Word	Type: 6th digit	0 to 9, A to Z	
044E _H	31103	Word	Type: 7th digit	0 to 9, A to Z	
044F _H	31104	Word	Type: 8th digit	1	
0450 _H	31105	Word	Type: 9th digit	0 to 9, A to Z	
0451 _H	31106	Word	Type: 10th digit	0 to 9, A to Z	
0452 _H	31107	Word	Type: 11th digit	0 to 9, A to Z	
0453 _H	31108	Word	Type: 12th digit	0 to 9, A to Z	
0454 _H	31109	Word	Type: 13th digit	0 to 9, A to Z	
0455 _H	31110	Word	Type: 14th digit	0 to 9, A to Z	
0456 _H	31111	Word	Type: 15th digit	0 to 9, A to Z	
0457 _H	31112	Word	Type: 16th digit	0 to 9, A to Z	
0458 _H	31113	Word	Type: 17th digit	0 to 9, A to Z	
0459 _H	31114	Word	Type: 18th digit	0 to 9, A to Z	
045A _H	31115	Word	Type: 19th digit	0 to 9, A to Z	
045B _H	31116	Word	Type: 20th digit	0 to 9, A to Z	
045C _H	31117	Word	Type: 21st digit	0 to 9, A to Z	
045D _H	31118	Word	Type: 22nd digit	0 to 9, A to Z	
045E _H	31119	Word	Type: 23rd digit	0 to 9, A to Z	
045F _H	31120	Word	Type: 24th digit	0 to 9, A to Z	
0460 _H	31121	Word	Type: 25th digit	0 to 9, A to Z	
0461 _H	31122	Word	Type: 26th digit	0 to 9, A to Z	
0462 _H	31123	Word	Board: 1st digit	0 to 9, A to Z	
0463 _H	31124	Word	Board: 2nd digit	0 to 9, A to Z	
0464 _H	31125	Word	Board: 3rd digit	0 to 9, A to Z	
0465 _H	31126	Word	Board: 4th digit	0 to 9, A to Z	
0466 _H	31127	Word	Board: 5th digit	0 to 9, A to Z	
0467 _H	31128	Word	Board: 6th digit	0 to 9, A to Z	
0468 _H	31129	Word	Board: 7th digit	0 to 9, A to Z	
0469 _H	31130	Word	Board: 8th digit	0 to 9, A to Z	

Notes

1. Set "0" for accessing to the area not used within address map.
2. For contents of *(a) to *(c), refer to Section 7.3 "Supplements to address map".

7.3 Supplement to address map

* (a) Register No. 30062 to 30131 (error log)

Up to 14 errors logged can be read in the order from the latest to older ones.

The contents are as follows.

Error No.: No. of produced error. Stored value is error number minus 1.

Error DAY: Date

Error HOUR: Indicates at what o'clock error occurred.

Error MIN: Indicates at what minutes error occurred.

Error TARGET: No. of Ch where error occurred.

Ch No. minus 1 is stored.

0 at error No. 3 or 10.

* (b) Register numbers 30181, 30182, 30183 (display information (1), (2), (3))

The display information is values for knowing the current display status of the instrument.

• Contents of values of display information (1) (status of each setting panel)

0: Measurement mode display (manual calibration display included)

1: Menu mode display

2: Changeover of range display

3: Calibration setting display

4: Alarm setting display

5: Automatic calibration setting display

6: Peak alarm setting display

7: Parameter setting display

8: Maintenance mode display

9: Factory mode display

10: Auto zero calibration setting display

• Contents of values of display information (2) (status at manual calibration)

0: Measurement mode display

4: Channel selection display at manual zero calibration

5: Zero calibration wait display at manual zero calibration

6: Zero calibration in progress display at manual zero calibration

7: Channel selection display at manual span calibration

8: Span calibration wait display at manual span calibration

9: Span calibration in progress display at manual span calibration

10: Error contents indication display

• Contents of values of display information (3)

Correspond to value of Ch (channel) from which the measurement mode is displayed.

Top channel number minus 1 is stored.

* (c) Register number 30189 (manual calibration channel)

Data for knowing a channel (component) which the cursor is positioned at to carry out a calibration at when a manual calibration is under way.

Channel number to carry out a calibration at minus 1 is stored.

8. TROUBLESHOOTING

If the communication is unavailable, check the following items.

- Whether all devices related to communication are turned on.
- Whether connections are correct.
- Whether the number of connected instruments and connection distance are as specified
- Whether communication conditions coincide between the master station (host computer) and slave stations (instrument)
 - Transmission speed : 38400bps
 - Data length : 8 bits
 - Stop bit : 1 bit
 - Parity : None

- Whether send/receive signal timing conforms to Section 5.6 in this manual.
- Whether the station No. designated as send destination by the master station coincides with the station No. of the connected instrument.
- Whether more than one instrument connected on the same transmission line shares the same station No.
- Whether the station No. of instruments is set at other than 0.
If it's 0, the communication function does not work.

Fuji Electric Co., Ltd.

International Sales Div

Sales Group

Gate City Ohsaki, East Tower, 11-2, Osaki 1-chome,
Shinagawa-ku, Tokyo 141-0032, Japan

<http://www.fujielectric.com>

Phone: 81-3-5435-7280, 7281 Fax: 81-3-5435-7425

<http://www.fujielectric.com/products/instruments/>
