



Service Manual

**INFRARED GAS
ANALYZER**

TYPE: ZRE

PREFACE

This service manual describes the infrared gas analyzer (Type: ZRE).

This service manual is intended for use with the instruction manual to help you in understanding maintenance and inspection for the infrared gas analyzer (ZRE). However, the basic operation of the analyzer is not covered in this manual.

This manual provides information about the parameter settings in the factory mode, adjustment and precautions for parts replacement, and troubleshooting for the infrared gas analyzer (ZRE) which are not covered in the instruction manual.

This service manual gives you useful hints to take immediate remedy for after-sales service.

- First read the instruction manual and service manual carefully until an adequate understanding is acquired, and then proceed to installation, operation and maintenance of the gas analyzer. Wrong handling may cause an accident or injury.
- The specifications of this analyzer will be changed without prior notice for further product improvement.
- Modification of this gas analyzer is strictly prohibited unless a written approval is obtained from the manufacturer. Fuji Electric will not bear any responsibility for a trouble caused by such a modification.

Manufacturer: Fuji Electric Co., Ltd.
Type: Described in Fuji Electric's company nameplate on main frame
Date of manufacture: Described in Fuji Electric's company nameplate on main frame
Product nationality: Japan

©Fuji Electric Co., Ltd. 2008

Request

- It is prohibited to transfer part or all of this manual without Fuji Electric's permission in written format.
- Description in this manual will be changed without prior notice for further improvement.

Issued in February, 2008
Rev. 1st edition April, 2011
Rev. 2nd edition June, 2013
Rev. 3rd edition October, 2013

CONTENTS



| | |
|---|----|
| PREFACE..... | i |
| CONTENTS | ii |
| CAUTION ON SAFETY | iv |
| 1. STRUCTURE OF ANALYZER AND NAMES OF PARTS | 1 |
| (1) Analyzer main unit (External/internal) | 1 |
| (2) Optical unit..... | 3 |
| (3) Connection of parts | 4 |
| 1) Wiring diagram..... | 4 |
| 2) Internal piping diagram and optical layout..... | 5 |
| 2. MAINTENANCE AND INSPECTION, AND REPAIR AND ADJUSTMENT AT REPLACEMENT OF MEASURING UNITS | 6 |
| (1) Light source..... | 6 |
| (2) Sector motor and sector..... | 6 |
| (3) Cell, cell window and O-ring | 7 |
| (4) Detector unit (except for O ₂ sensor)..... | 7 |
| (5) Built-in O ₂ sensor (paramagnetic)..... | 8 |
| (6) Built-in O ₂ sensor (galvanic cell type) | 8 |
| (7) Printed circuit board (see printed board diagram at the back of the manual)..... | 9 |
| 1) Main board..... | 9 |
| 2) AIO board..... | 9 |
| (8) Liquid crystal display (LCD) | 9 |
| (9) Power supply | 10 |
| (10) Operation Parts..... | 11 |
| 3. FACTORY MODE..... | 12 |
| (1) How to go to factory mode..... | 12 |
| (2) Setting change items | 13 |
| 1) Zero limit | 13 |
| 2) Range limit | 14 |
| 3) Calibration coefficient | 15 |
| (3) Setting value reference items | 16 |
| 1) A/D data..... | 16 |
| 4. ERROR JUDGEMENT CRITERIA FOR ERROR CODES | 17 |
| 5. TROUBLESHOOTING AND DATA COLLECTION | 19 |
| (1) Countermeasures against trouble | 19 |
| 1) Zero calibration can not be performed..... | 19 |
| 2) Span calibration can not be performed..... | 19 |
| 3) Drift | 19 |
| 4) Readings are high or low too much. | 19 |
| 5) Readings are not increased | 19 |
| (2) Data sampling at trouble | 20 |
| 6. ADJUSTMENT IN HEAT TREATMENT FURNACE | 21 |
| (1) Method for span calibration by standard gas with the same composition as plant gas | 21 |
| (2) Method for span calibration by check gas..... | 22 |
| 7. Moisture interference adjustment (NO, SO ₂ only) | 23 |

| | |
|---|-----|
| APPENDIX 1. MEASURING PRINCIPLE DIAGRAM | A-1 |
| APPENDIX 2. SOFT FLOW DIAGRAM | A-2 |
| APPENDIX 3. PRINTED BOARD DIAGRAM..... | A-3 |
| Main board..... | A-3 |
| AIO board..... | A-4 |
| Amplifier board | A-4 |



CAUTION ON SAFETY

First of all, read this “Caution on safety” carefully, and then use the analyzer in the correct way.

- The cautionary descriptions listed here contain important information about safety, so they should always be observed. Those safety precautions are ranked in 3 levels, “DANGER”, “CAUTION” and “PROHIBITION”.



| | |
|--|---|
|  DANGER | Wrong handling may cause a dangerous situation, in which there is a risk of death or heavy injury. |
|  CAUTION | Wrong handling may invite a dangerous situation, in which there is a possibility of medium-level trouble or slight injury or only physical damage is predictable. |
|  PROHIBITION | Items which must not be done are noted. |

Caution on installation and transport of gas analyzer



| | |
|--|--|
|  DANGER | <ul style="list-style-type: none"> • This unit is not explosion-proof type. Do not use it in a place with explosive gases to prevent explosion, fire or other serious accidents. |
|  CAUTION | <ul style="list-style-type: none"> • For installation, observe the rule on it given in the instruction manual and select a place where the weight of gas analyzer can be endured. Installation at an unsuited place may cause turnover or fall and there is a risk of injury. • For lifting the gas analyzer, be sure to wear protective gloves. Bare hands may invite an injury. • Before transport, fix the casing so that it will not open. Otherwise, the casing may be separated and fall to cause an injury. • During installation work, care should be taken to keep the unit free from cable chips or other foreign objects. Otherwise, it may cause fire, trouble or malfunction of the unit. |

| Caution on piping | |
|---|---|
|  DANGER | <p>In piping, the following precautions should be observed. Wrong piping may cause gas leakage.</p> <p>If the leaking gas contains a toxic component, there is a risk of serious accident being induced.</p> <p>Also, if combustible gas is contained, there is a danger of explosion, fire or the like occurring.</p> <ul style="list-style-type: none"> • Connect pipes correctly referring to the instruction manual. • Exhaust should be led outdoors so that it will not remain in the locker and installation room. • Exhaust from the analyzer should be relieved in the atmospheric air in order that an unnecessary pressure will not be applied to the analyzer. Otherwise, any pipe in the analyzer may be disconnected to cause gas leakage. • For piping, use a pipe and a pressure reducing valve to which oil and grease are not adhering. If such a material is adhering, a fire or the like accident may be caused. |

| Caution on wiring | |
|--|---|
|  CAUTION | <ul style="list-style-type: none"> • Wiring work must be performed with the main power set to OFF to prevent electric shocks. • Enforce construction of class-3 grounding wire by all means. If the specified grounding construction is neglected, a shock hazard or fault may be caused. • Wires should be the proper one meeting the ratings of this analyzer. If using a wire which cannot endure the ratings, a fire may occur. • Be sure to use a power supply of correct rating. Connection of power supply of incorrect rating may cause fire. |

| Caution on use | |
|--|--|
|  DANGER | <ul style="list-style-type: none"> • For correct handling of calibration gas or other reference gases, carefully read their instruction manuals beforehand. Otherwise, carbon monoxide or other hazardous gases may cause an intoxication particularly. |
|  CAUTION | <ul style="list-style-type: none"> • Before leaving unused for a long time or restarting after left at such a status for an extended length of time, follow the directions of each instruction manual because they are different from normal starting or shutdown. Otherwise, the performance may be poor and accidents or injuries may be caused. • Do not operate the analyzer for a long time with its door left open. Otherwise, dust, foreign matter, etc. may stick on internal walls, thereby causing faults. |

| Caution on use | |
|--|--|
|  PROHIBITION | <ul style="list-style-type: none"> • Do not allow metal, finger or others to touch the input/output terminals in the analyzer. Otherwise, shock hazard or injury may occur. • Do not smoke nor use a flame near the gas analyzer. Otherwise, a fire may be caused. • Do not allow water to go into the gas analyzer. Otherwise, hazard shock or fire in the analyzer may be caused. |

| Caution on maintenance and check | |
|--|--|
|  DANGER | <ul style="list-style-type: none"> • When doors are open during maintenance or inspection, be sure to purge sufficiently the inside of the gas analyzer as well as the measuring gas line with nitrogen or air, in order to prevent poisoning, fire or explosion due to gas leak. |
|  CAUTION | <p>Be sure to observe the following for safe operation avoiding the shock hazard and injury.</p> <ul style="list-style-type: none"> • Remove the watch and other metallic objects before work. • Do not touch the analyzer with wet-handed. • If the fuse is blown, eliminate the cause, and then replace it with the one of the same capacity and type as before. Otherwise, shock hazard or fault may be caused. • Do not use a replacement part other than specified by the analyzer maker. Otherwise, adequate performance will not be provided. Besides, an accident or fault may be caused. • Replacement parts such as a maintenance part should be disposed of as incombustibles. • Please be sure to check about the gas analyzer being in a safe state after the end of work. (Piping, Wiring, Screws etc.) |

| Others | |
|--|--|
|  CAUTION | <ul style="list-style-type: none"> • If the cause of any fault cannot be determined despite reference to the instruction manual, be sure to contact your dealer or Fuji Electric's technician in charge of adjustment. If the analyzer is disassembled carelessly, you may have a shock hazard or injury. |

1. STRUCTURE OF ANALYZER AND NAMES OF PARTS

(1) Analyzer main unit (External/internal)

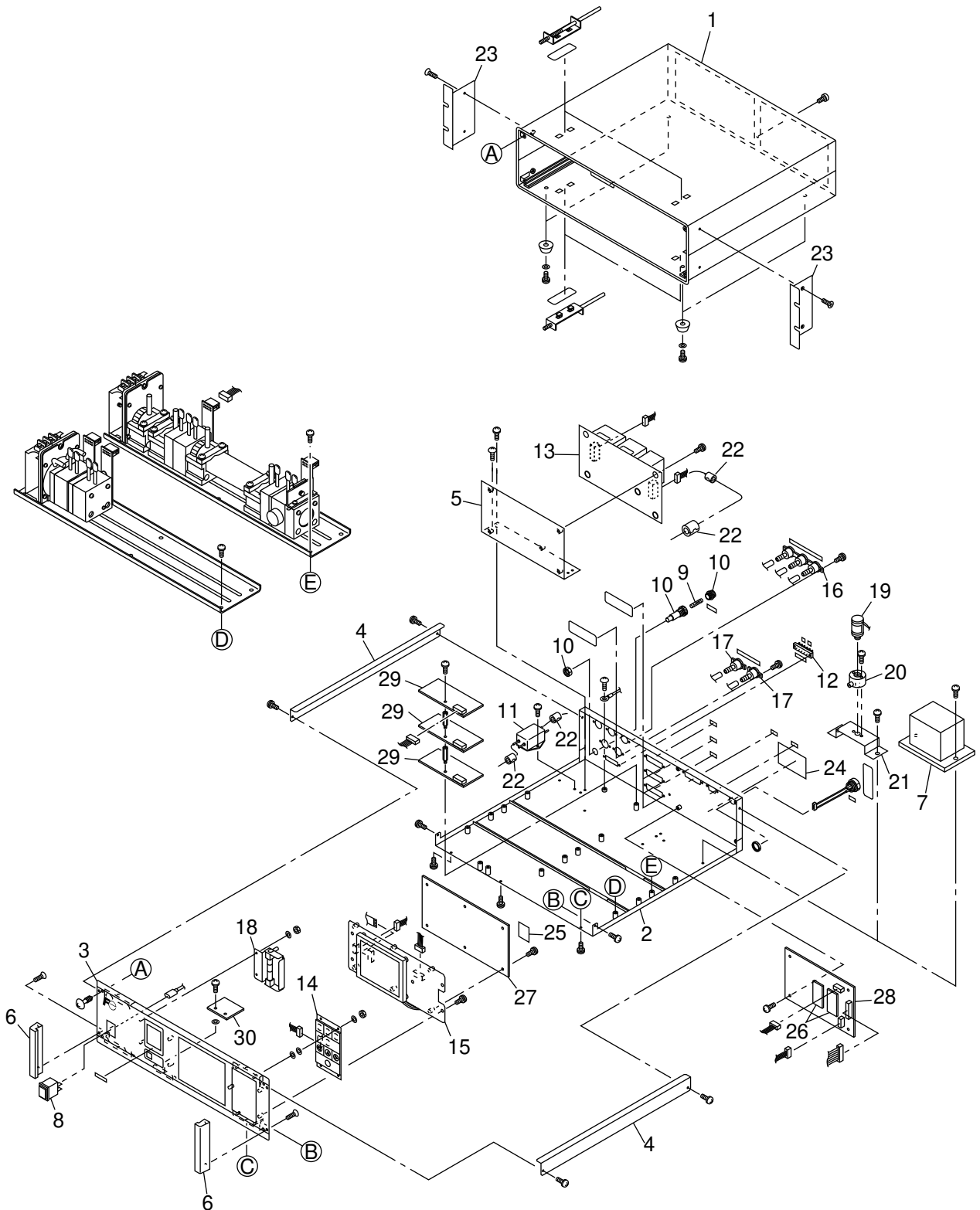

| Part No. | Part name | Part No. | Part name |
|----------|--|----------|---------------------------------------|
| 1 | Case ass'y | 16 | Triple gas port unit |
| 2 | Base | 17 | Gas port unit |
| 3 | Front panel ass'y | 18 | Flow checker ass'y |
| 4 | Angle | 19 | Galvanic O ₂ sensor unit |
| 5 | Power supply mounting plate | 20 | Galvanic O ₂ sensor socket |
| 6 | Grip | 21 | Galvanic O ₂ sensor plate |
| 7 | Magnetic force type O ₂ sensor unit | 22 | Ferrite core |
| 8 | Power switch | 23 | 19 -inch mounting bracket |
| 9 | Pipe fuse | 24 | Specification name plate |
| 10 | Fuse holder | 25 | ROM historical name plate |
| 11 | Noise filter | 26 | AO board |
| 12 | Power supply terminal block | 27 | Main board |
| 13 | Power supply | 28 | AIO board |
| 14 | Key unit | 29 | DIO board |
| 15 | LCD | 30 | USB board |

(2) Optical unit

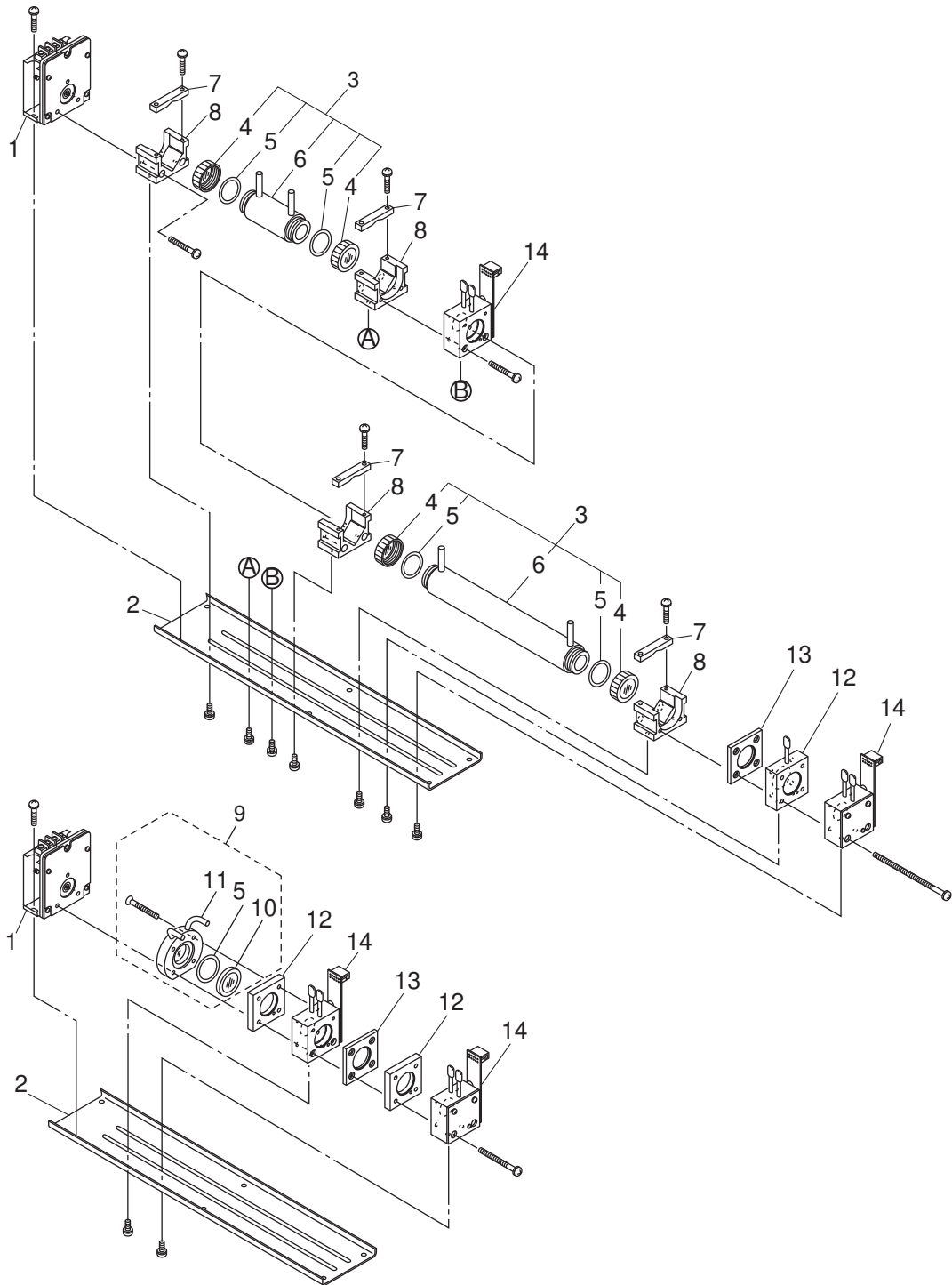

| Part No. | Part name | Part No. | Part name |
|----------|-------------------|----------|-------------------|
| 1 | Light source unit | 8 | Cell fixing block |
| 2 | Base plate | 9 | Block cell ass'y |
| 3 | Pipe cell ass'y | 10 | Window |
| 4 | Window ass'y | 11 | O ring |
| 5 | O ring | 12 | Gas filter |
| 6 | Pipe cell | 13 | Filter |
| 7 | Cell mounting | 14 | Detector unit |

(3) Connection of parts

1) Wiring diagram

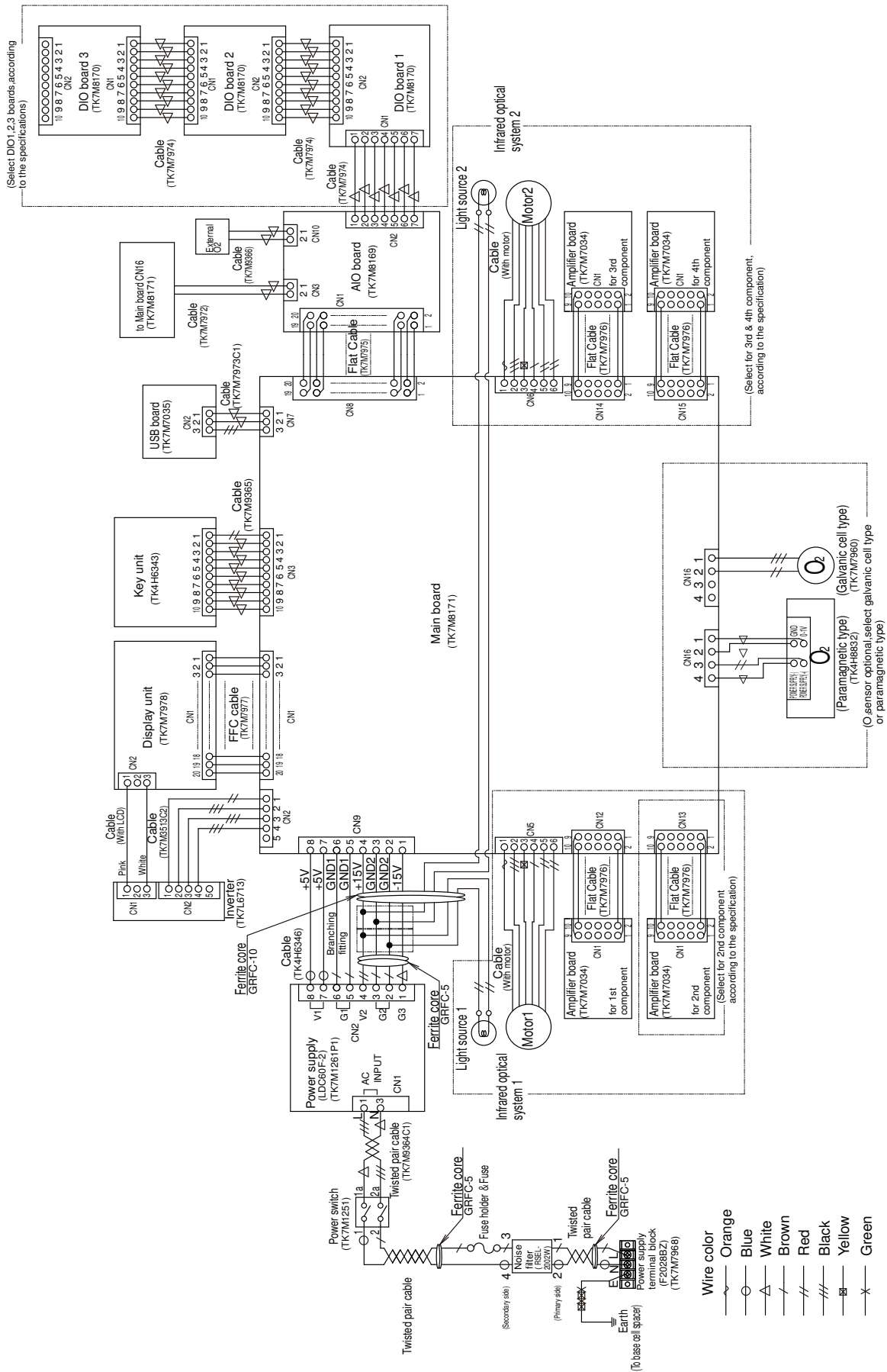

2) Internal piping diagram and optical layout

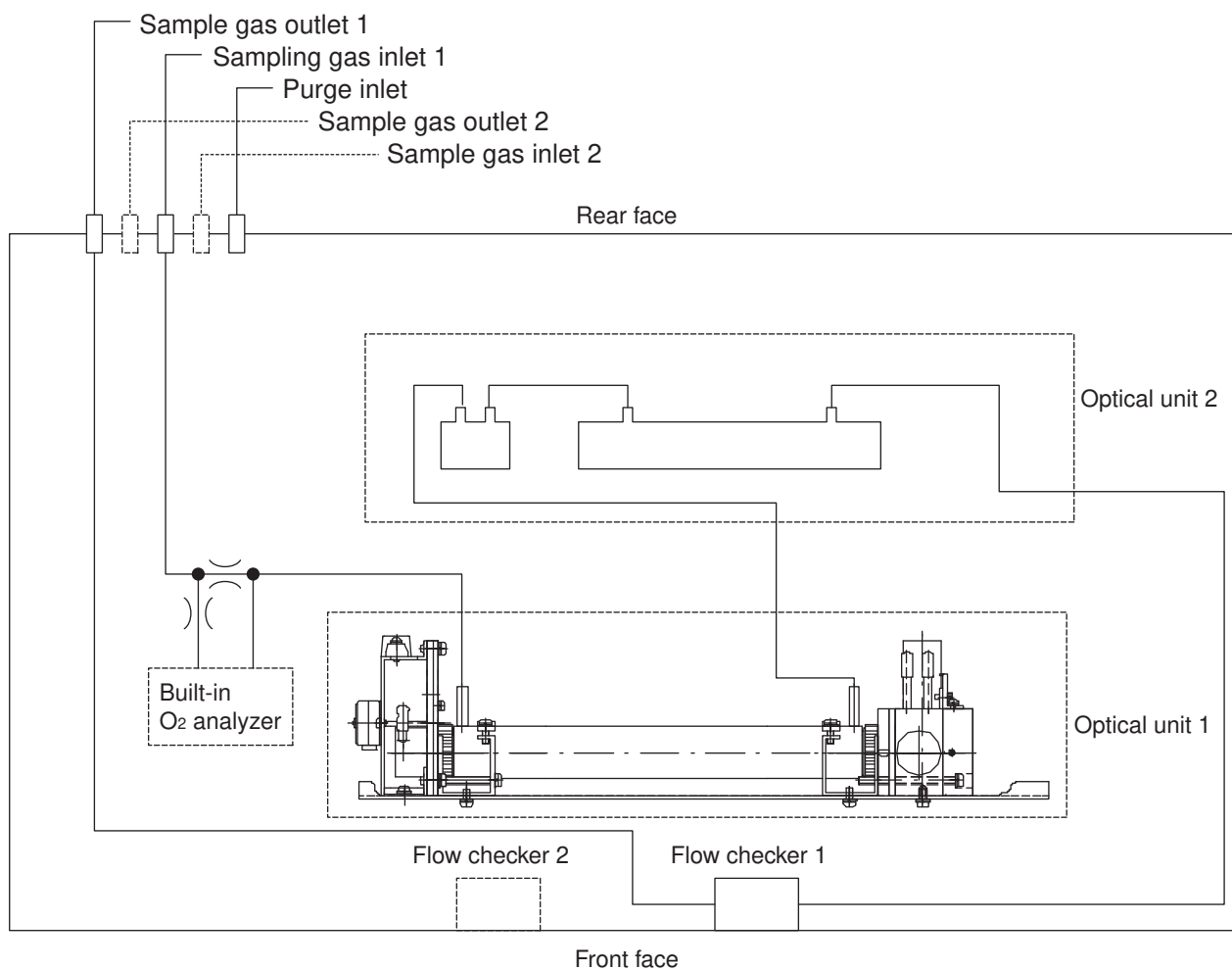

Correspondence of measurable components and Optical units

| Measurable components | Optical unit 1 | Optical unit 2 |
|---|---------------------------|----------------------------------|
| Single-component (NO, SO ₂ , CO ₂ , CO, CH ₄) | Each measurable component | None |
| Double-component (CO ₂ /CO) | CO ₂ /CO | None |
| Double-component (NO/CO, NO/SO ₂) | NO NO | CO SO ₂ |
| Three-component (NO/SO ₂ /CO) | NO | SO ₂ /CO |
| Four-component (NO/SO ₂ /CO ₂ /CO) | NO/CO | SO ₂ /CO ₂ |

2. MAINTENANCE AND INSPECTION, AND REPAIR AND ADJUSTMENT AT REPLACEMENT OF MEASURING UNITS

(1) Light source

- Recommended period of replacement : 5 years

- 1) Error mode

Error mode (1) : Short circuit in and disconnection from the light source electrically heated wire.

Phenomena : Scale-out indication of analyzer , Error-1 occurs.

Check : Turn OFF the power of the analyzer and remove the power cable connected to the light source.
Measure resistance between 2-pin terminals at the light source, and the resistance value must be $37\Omega \pm 2\Omega$. If resistance values are infinite, the light source may be broken. As the resistance value is decreased, the indication will be drifted in the minus direction.

Error mode (2) : Sealed gas in light source leaks.

Phenomena : Fluctuated Indication

Check : If the analyzer output is drifted due to ambient conditions around the analyzer and other units are normal except for the light source, sealed gas may leak.

- 2) Measures : If the light source is found defective, replace the light source motor unit.
- 3) Replacement : To replace the motor unit, remove the cable between 2-pin terminals and motor connector.
Loosen 2 screws that fasten the light source motor unit to the optical base plate .
- 4) Adjustment after replacement :
Perform zero and span calibration.

< Motor unit for light source >

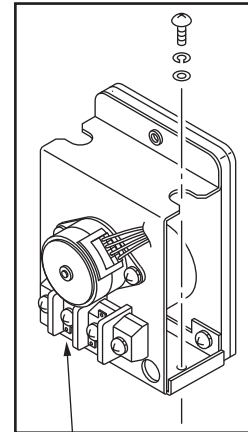

Measure the resistance between terminals with cables disconnected.

(2) Sector motor and sector

- Recommended period of replacement : 5 years

- 1) Error mode

Error mode (1) : Motor rotation stop

Phenomena : Scale-out indication of analyzer , Error- 1 occurs.

Check : With the analyzer power ON, check that the shaft is normally rotating as viewed from the motor.

Error mode (2) : Unstable rotation of a sector

Phenomena : Scale-out indication of analyzer: Error- 1 occurs.
Indication is fluctuated.

Check : With the analyzer power ON, check if unusual noise is generated from the motor due to metal contact. If no noise is heard, remove the light source motor unit.
Turn ON the power of the analyzer and check the rotation of motor shaft and sector

- 2) Measures : If the sector motor is found defective, replace the light source motor unit.
- 3) Replacement : To replace the motor unit, remove the cable between 2-pin terminals and motor connector.
Loosen 2 screws that fasten the light source motor unit to the optical base plate.
- 4) Adjustment after replacement :
Perform zero and span calibration.

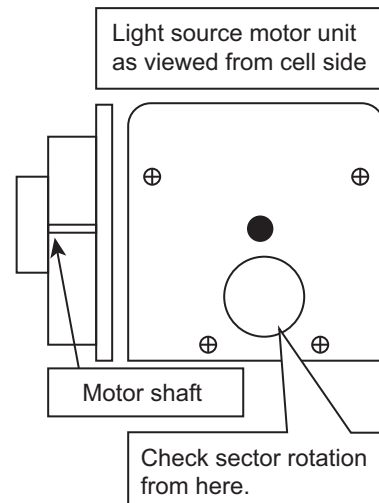

(3) Cell, cell window and O-ring

- Service life : Usable unless contamination or corrosion is excessive.
- Recommended period of replacement : 2 years with O-ring
- 1) Error mode
 - Error mode (1) : Contamination of cell, mixture of foreign matter, and contamination of cell window
 - Phenomena : Scale-out indication, drift and calibration error occurred to analyzer
 - Check : Disassemble the cell to assure that the inside is clean.
 - Error mode (2) : Crack in cell window
 - Phenomena : No change in indication, slow response, calibration error, and indication fluctuation
 - Check : Perform a visual check of the cell window.
- 2) Measures : Cell : Clean the inside of the cell (refer to the instruction manual for details).
 Replace if the inside is exposed to excessive contamination or corrosion.
 Cell window : Clean the cell window. Replace if the inside is exposed to excessive contamination.
- 3) Replacement : For replacement, refer to the instruction manual.
- 4) Adjustment after clean and replacement :
 Perform zero and span calibration and check response time for each component.

(4) Detector unit (except for O₂ sensor)

- Recommended period of replacement : 5 years
- 1) Error mode
 - Error mode (1) : Sensitivity deterioration due to sealed gas leak
 - Phenomena : Calibration error and fluctuation in indication
 - Check : Check indication value at zero point
 Check the indication value for each component on the “Sensor Input Value” screen in the “Maintenance” mode. If the light source is in normal condition and the cell is free of contamination, the counter value indicates 35,000 to 55,000 when zero gas is supplied. If the counter value is below the range, sensitivity can be degraded.
 - Error mode (2) : Damage to mass-flow detector
 - Phenomena : Scale-out indication of analyzer , Error- 1 occurs
 - Check : Turn OFF the power of the analyzer and disconnect the connector connected from the detector to PC board. Measure resistance between J1 – J4 and J2 – J3 of the amplifier board on the detector. The measure values must be between 25Ω and 60Ω. If the resistance value is fluctuated beyond the specified range, the detector element may be damaged.

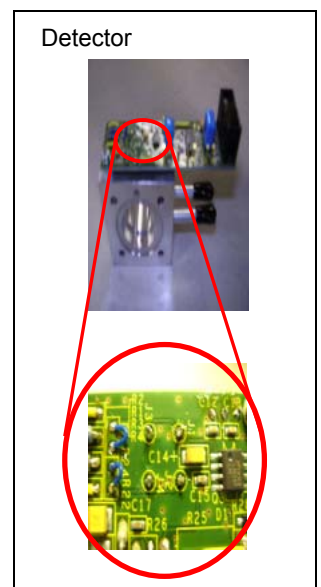

Note : Do not use measurement analyzer that allows a current of 2mA or more to be supplied when measuring resistance, otherwise the element can be damaged.

- Error mode (3) : Detector voltage, control failure
 - Phenomena : Calibration error and fluctuation in indication
 - Check : Check amplifier board and measure voltage between DV1 – GND of the terminal.
 It is normal if the value is within ± 0.4 of the voltage specified on the label.
- 2) Measures : Replace detector.
- Precautions on replacement:
 - The Amplifier board is set according to the specifications of each detector. When ordering, notify analyzer serial number, detector serial number and the detector type (ex. “NO-H”). So the Amplifier board has suitable gain in it.

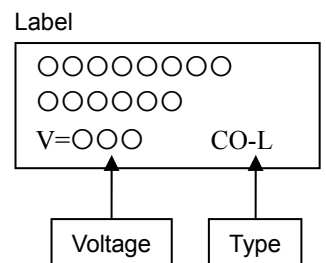

- 3) Replacement :
 - When a cell is a block cell, remove the light source motor unit. The light source motor unit and block cell are screwed to the detector. Unscrew the detector and then the light source motor unit and block cell can be separated from the detector. After that, unscrew the block cell side, the block cell can be separated from the detector. Install a new detector in reverse procedure of removal.

Caution: Mount the detector in parallel with the cell window and the block cell so as not to cause poor sealing.
 - When a cell is a pipe cell, the detector is screwed to the rear of the optical base plate. First, remove the base plate and then unscrew the detector. Install a new detector in reverse procedure of removal.
- 4) Adjustment after replacement :

After replacement, check next three subjects.

 - 1) check the voltage (DV1-GND on Amplifier board) shown above.
 - 2) check the counter value indicates shown above (with zero gas supply).
 - 3) check resistance (J1-J4, J2-J3 on Amplifier board) shown above.

And, perform zero and span calibration.

(5) Built-in O₂ sensor (paramagnetic)

- Error mode : Damage to O₂ detector
- Phenomena : O₂ detector indication is at 0 and O₂ detector will not even respond to span gas.
- Check : Check of O₂ input voltage

Remove the O₂ sensor cable (CN16) on the main board and apply a digital voltage meter between the connector (1) – (2) and then check that it reads about 0 V with zero gas and 0.5V to 1V with span gas. If no change in voltage is made with zero and span gases, O₂ detector can be damaged.
- Measures : Replace O₂ detector
- Replacement : Turn OFF the analyzer main unit

Since the O₂ detector case is common to the 0V line, be careful when installing it avoid contacting the analyzer main unit case and O₂ detector case. Generally, an insulation mounting plate is supplied.
- Adjustment after replacement : Perform zero and span calibration.

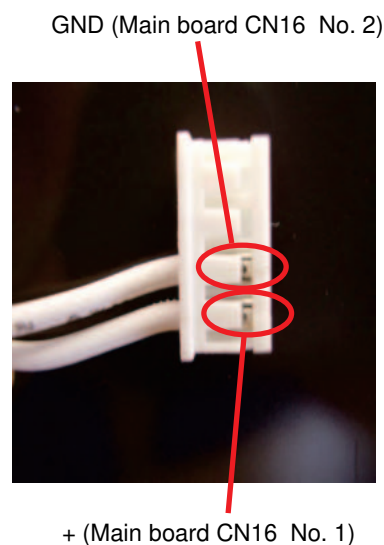

(6) Built-in O₂ sensor (galvanic cell type)

- Recommended period of replacement : 2 years
- Error mode : Sensor deterioration.
- Phenomena : Span drift and fluctuation in indication by sensitivity deterioration.
- Check : Same as Built-in O₂ sensor (paramagnetic type). Refer to (5) Check shown above.
- Measures : Same as Built-in O₂ sensor (paramagnetic type).
- Replacement : Turn OFF the analyzer main unit. Disconnect the connector, piping and replace it with a new one.
- Adjustment after replacement: Perform zero and span calibration.

(7) Printed circuit board (see printed board diagram at the back of the manual)

1) Main board (see Appendix 3)

- Check : Voltage check

| Check terminal | Check voltage | Contents |
|----------------|---------------|---------------|
| TPVC1-TPVS1 | +5 ±0.3 V | Digital 5 V |
| TP15-TPG1 | +15 ±0.5 V | Analog 15 V |
| TPN15-TPG1 | -15 ±0.5 V | Analog -15 V |
| TPVH1-TPVS1 | +3.3 ±0.2 V | Digital 3.3 V |
| TPVL1-TPVS1 | +1.25 ±0.1 V | Digital 1.25V |

- Precautions on replacement:
 - The main board is set according to the specifications of each analyzer. When ordering, notify analyzer serial number. So the main P.C.B has suitable parameter in it.
 - Do not remove or plug the connector from or into the board with the power ON, or electronic parts may be damaged. Before replacement, be sure to turn OFF the analyzer.
- Adjustment after replacement :

After replacement, check for the voltage shown above.
Perform contrast adjustment while viewing the LCD. Determine an easy-to-see height and adjust contrast.
“Menu mode” ⇒ “Parameter” ⇒ “contrast” (Refer to the instruction manual for details of operating method.)
Press the switch to check that all keys are normally operated.

2) AIO board (see Appendix 3)

- Adjustment after replacement :

Output check (Adjust if output is offset.)
(Refer to the instruction manual for details of operating method.)

(8) Liquid crystal display (LCD)

- Service life of parts : 30,000 hours Lighting continuously
- Error mode : Deterioration
- Phenomena : LCD is not displayed, or the display is dim or flickers.
- Check : Adjust contrast (remove or plug the connector). Check connection to the main board.
- Countermeasures against error : Replace LCD.
- Replacement : Turn OFF the power. Disconnect the connector and replace it with a new one.
- Adjustment after replacement :

Adjust the contrast (refer to the instruction manual for details of operating method.).

(9) Power supply

- Recommended period of replacement : 5 years
- Error mode : Power-down
- Phenomena : No display and no output
- Check : Check if short circuit occurs.
 Disconnect the secondary SW power connector. Turn ON the power and check the voltage at the connector. If no voltage is applied to it, replace.
- Measures : Replace the power supply
- Replacement : Turn OFF the analyzer power. Disconnect the cable from the Main board and replace it with a new one.
- Check after replacement :
 Check the power supply voltage on the Main board.

LDA60F-2

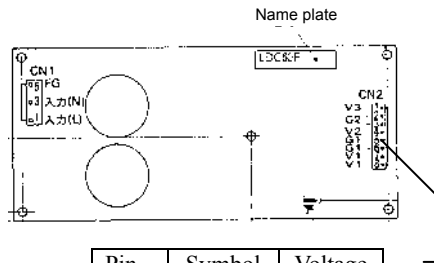

| Pin | Symbol | Voltage |
|-----|--------|------------------|
| 1 | V3 | -15V |
| 2 | G2 | Ground (±15V) |
| 3 | G2 | Ground (±15V) |
| 4 | V2 | +15V |
| 5 | G1 | Ground (+15V) |
| 6 | G1 | Ground (+15V) |
| 7 | V1 | +5V |
| 8 | V1 | +5V |

(10) Operation Parts

- Error mode : Wear on switching
- Phenomena : Faulty operation
- Check : Be sure to turn OFF the main unit power supply before inspecting.
 - 1) Remove the cable.
 - 2) Measure the resistance for connector pin No. of switch that does not function with a tester (see Allocation of Connector Table).
 - 3) Press the switch that does not function to check the continuity.
 Normally it is conductive when pressing the switch and opens when releasing the switch.

Allocation of Connector

| Connector pin No. | Switch name |
|-------------------|-------------|
| 2-10 | MODE |
| 3-10 | ▶ |
| 4-10 | ▲ |
| 5-10 | ▼ |
| 6-10 | ESC |
| 7-10 | ENTER |
| 8-10 | ZERO |
| 9-10 | SPAN |

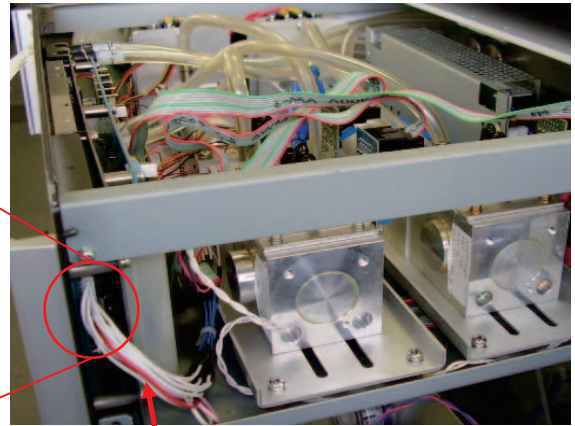
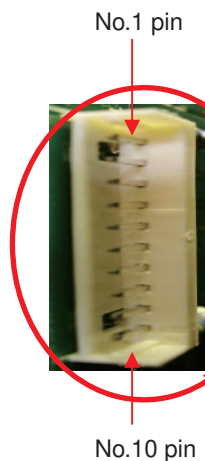

Cable

- Measures : Replace the operation unit.
- Replacement : Remove the main board and the main board mounting plate. Remove the nut, spring washer, washer at 4 corners of the operation unit. You can now remove the operation unit and replace it with a new one.
Assemble all the parts in reverse order of disassembly. Finally insert the cable into the connector.
- Check after replacement :
Check that all keys function.

3. FACTORY MODE

(1) How to go to factory mode

Point the cursor to “6. To Factory Mode” by using the ▲ or ▼ key on the Maintenance Mode screen and enter the ENT key. Then, the password input screen appears.

| | |
|--|-----------------------|
| Maintenance Mode | Select operating item |
| 1. Sensor Input Value 2. Error Log 3. Cal. Log 4. Output Adj. 5. Other Parameter 6. To Factory Mode | |



Enter the password.
 To select setting items, set “4 0 4 3”. (“4. Option”, “5. Pressure”, “12. Others”, “14. Coefficient” are settable with “4 0 4 3”. Items 1, 2, 3, 6, 7, 8, 9, 11, 13 and 15 can be viewed).
 Select digits by the ► key.
 Change numerical values by using ▲ or ▼ key.

| |
|----------------------|
| Input Password: 4043 |
|----------------------|



After password entry has been completed, press the ENT key, and the Factory Mode initial screen appears

- How to select setting item from Factory Mode screen

On the Factory Mode screen that appears, point the cursor to the item you want by using the ►, ▲ or ▼ key. To get access to each setting screen, press the ENT key.

| | |
|--|---|
| Factory Mode | Select operating item |
| 1. PILC Code 2. Ch No. 3. Ch Data 4. Option 5. Pressure 6. Linearization 7. Temperature 8. Output SW 9. DIO SW | 10. Memory Access 11. A/D Data 12. Others 13. Interference 14. Coefficient 15. Calculation |



To return from each setting screen to the initial screen, press the ESC key.

When escaping from the Factory Mode screen to the Maintenance Mode screen, press the ESC key.

Into each parameter screen



(2) Setting change items

1) Zero limit

- Function: Switches measured concentration values below zero to either display or no display mode.
- Operation method:

Changes the setting in “Factory mode”, “12. Others” and “Zero limit”.

Set values are inverted by pressing the  key, when the cursor is aligned with the “Zero limit”.

Switch between “ON” and “OFF” by the  or  key.

Establish the setting contents by pressing the  key.

If you don't want to establish the contents, press the  key.

- Setting contents:
 - OFF: does not display and output values below zero
 - ON: displays and outputs values below zero.
- Initial value: “OFF” (default: Disappear)

Factory mode initial screen
The cursor is in 12.



| Factory Mode Others | Select an item |
|--|----------------|
| <input checked="" type="checkbox"/> ZERO limit | OFF |
| Range limit | ON |
| AO No. | 12 |
| Language | ENG |
| ZERO gas | Cylinder |
| Protocol | MO |
| Varied Range | ON |
| DIO No. | 0 |







| Factory Mode Others | The value under zero is disappeared |
|------------------------|--|
| ZERO limit | OFF |
| Range limit | ON |
| AO No. | 12 |
| Language | ENG |
| ZERO gas | Cylinder |
| Protocol | MO |
| Varied Range | ON |
| DIO No. | 0 |

* This mode is used at the time of adjustment in order to check a display. If the minus display (Zero limit) is set to Appear, be sure to return the setting to “OFF” after adjustment.

2) Range limit

- Function : Measured concentration values used for O₂ correction or moving average computation can be switched to either with limiter (upper limit 110%F.S.) or without limiter (the graph within the panel).
- Operation method:
Changes the setting in “Factory mode”, “12. Others” and “Zero limit”.

When the cursor is in front of the “Range limit”, press the  key, and the setting value is highlighted.

Switch between “ON” and “OFF” by the  or  key, and establish the setting contents by pressing the  key.

- Setting contents:
ON: Displays and outputs values up to 110%F.S.
OFF: Displays and outputs values up to the graph is within the panel.
- Initial value: “ON”

Factory mode initial screen
The cursor is in 12.



| Factory Mode | Select an item |
|---|----------------|
| Others | |
| ZERO limit | OFF |
| <input checked="" type="checkbox"/> Range limit | ON |
| AO No. | 12 |
| Language | ENG |
| ZERO gas | Cylinder |
| Protocol | MO |
| Varied Range | ON |
| DIO No. | 0 |



| Factory Mode | Range limit is usable |
|--------------|-----------------------|
| Others | |
| ZERO limit | OFF |
| Range limit | ON |
| AO No. | 12 |
| Language | ENG |
| ZERO gas | Cylinder |
| Protocol | MO |
| Varied Range | ON |
| DIO No. | 0 |

3) Calibration coefficient

Function: Displays calibration coefficient.

Operation: The coefficient initial screen is as shown at right.

Factory mode initial screen
The cursor is in 14.



R1 and R2 represent range 1 and 2.

Zero calibration coefficient is displayed on the left side of screen, and span calibration coefficient is displayed on the right side.

| Factory Mode coefficient | | | |
|--------------------------|----|----------|--------|
| Ch1 | R1 | 01.00000 | 1.0000 |
| N0x | R2 | 01.00000 | 1.0000 |
| Ch2 | R1 | 01.00000 | 1.0000 |
| S02 | R2 | 01.00000 | 1.0000 |
| Ch3 | R1 | 01.00000 | 1.0000 |
| C02 | R2 | 01.00000 | 1.0000 |
| Ch4 | R1 | 01.00000 | 1.0000 |
| C0 | R2 | 01.00000 | 1.0000 |
| Ch5 | R1 | +0000 | 1.0000 |
| O2 | R2 | +0000 | 1.0000 |



How to change numeric value;

Select a desired item using the ▲ and ▼ keys.

Press the ENT key to enter the screen of the item selected.

Move the cursor in front of the value to be changed using the ►, ▲ or ▼ key and then press the ENT key, and the value is highlighted.

Change the numeric value and move the digits using the ►, ▲ or ▼ key. Establish the setting contents by pressing the ENT key. If you don't want to establish the contents, press the ESC key.

| Factory Mode coefficient | | | |
|--------------------------|----|----------|--------|
| Ch1 | R1 | 01.00000 | 1.0000 |
| N0x | R2 | 01.00000 | 1.0000 |
| Ch2 | R1 | 01.00000 | 1.0000 |
| S02 | R2 | 01.00000 | 1.0000 |
| Ch3 | R1 | 01.00000 | 1.0000 |
| C02 | R2 | 01.00000 | 1.0000 |
| Ch4 | R1 | 01.00000 | 1.0000 |
| C0 | R2 | 01.00000 | 1.0000 |
| Ch5 | R1 | +0000 | 1.0000 |
| O2 | R2 | +0000 | 1.0000 |

(3) Setting value reference items

1) A/D data

- Function : Measures the counter readings immediately after A/D conversion.
- Operation : To measure the counter readings, press the **(ENT)** key on the “Factory Mode” initial screen.

| No | Count | No | Count | No | Count |
|----|----------------------|----|----------------------|----|------------|
| 0 | Ch1 input value | 8 | Temperature sensor 4 | 16 | Ground |
| 1 | Ch2 input value | 9 | Temperature sensor 5 | 17 | Gitter 1-2 |
| 2 | Ch3 input value | 10 | Gitter 1-1 | 18 | Gitter 2-2 |
| 3 | Ch4 input value | 11 | Gitter 2-1 | 19 | Gitter 3-2 |
| 4 | Ch5 input value | 12 | Gitter 3-1 | 20 | Gitter 4-2 |
| 5 | Temperature sensor 1 | 13 | Gitter 4-1 | | |
| 6 | Temperature sensor 2 | 14 | Pressure | | |
| 7 | Temperature sensor 3 | 15 | Reference voltage | | |

Factory mode initial screen
The cursor is in 11.



| Factory Mode A/D Data | | | | | |
|-----------------------|-------|----|-------|----|-------|
| NO | Count | NO | Count | NO | Count |
| 0 | 65444 | 8 | 44857 | 16 | 7645 |
| 1 | 56779 | 9 | 45667 | 17 | 47888 |
| 2 | 66982 | 10 | 37889 | 18 | 47893 |
| 3 | 85663 | 11 | 37465 | 19 | 47261 |
| 4 | 6855 | 12 | 37897 | 20 | 47893 |
| 5 | 44939 | 13 | 37665 | | |
| 6 | 44756 | 14 | 42367 | | |
| 7 | 44869 | 15 | 40029 | | |

When supplying zero gas (dry);

No. 0 (Infrared ray component 1) 35,000 to 55,000

No. 1 (Infrared ray component 2) 35,000 to 55,000

No. 2 (Infrared ray component 3) 35,000 to 55,000

No. 3 (Infrared ray component 4) 35,000 to 55,000

No. 4 (O₂ sensor input) 18,000 to 22,000

If A/D counts are within the range, there is no problem. If infrared ray composition 2, 3, 4 and O₂ sensor do not exist, ignore No. 1, 2, 3 and 4.

4. ERROR JUDGEMENT CRITERIA FOR ERROR CODES

* This section covers the error judgement criteria for error codes.

For the contents of errors, refer to Instruction Manual.

| Error No. | Contents | Criteria |
|-----------|--|---|
| Error 1 | Light source and data are faulty | Detector signals generated due to motor chopping are converted into rectangular waves and rectangular waves are monitored. If waves are not generated or irregular, an error occurs. |
| Error 2 | Monitor gitter resistance (voltage). | When the gitter resistance (voltage) is outside the following range after A/D conversion, error occurs. A/D conversion value (count) can be checked on the "A/D Data" of the Factory mode. Monitoring can be performed for No.17 (Gitter 1-2), No.18 (Gitter 2-2), No.19 (Gitter 3-2) and No.20 (Gitter 4-2) only. $10,000 \leq \text{No.17 to 20} \leq 59,999$ |
| Error 3 | A/D conversion signal is faulty. | Monitor A/D conversion reference voltage (main printed circuit board). When the reference voltage is outside the following range after A/D conversion, error occurs. A/D conversion values (counter values) can be checked by the counter indication when the Factory mode screen is displayed. $35,000 \leq \text{No. 15} \leq 55,000$ |
| Error 4 | Zero calibration is not within the allowable range. | Infrared component: $0.5 \leq \text{zero calibration coefficient} \leq 5$ Other than infrared component: $-2,000 \leq \text{zero calibration coefficient} \leq 12,000$ |
| Error 5 | A amount of zero calibration is over 50% of full scale. | This error occurs in the following condition. $50\% \text{ of FS} <$ $(\text{Zero calibration concentration set value}) - (\text{current display})$ |
| Error 6 | Span calibration is not within the allowable range. | When span calibration coefficient is not within the following range, error occurs. Infrared component: $0.1 \leq \text{span calibration coefficient} \leq 10$ External input type O ₂ / built-in galvanic cell type O ₂ / built-in paramagnetic O ₂ : $0.5 \leq \text{span calibration coefficient} \leq 16$ Zirconia O ₂ : $6,000 \leq \text{span calibration coefficient} \leq 32,000$ |
| Error 7 | An amount of span calibration is over 50% of full scale. | This error occurs in the following condition. $50\% \text{ of FS} <$ $(\text{Span calibration concentration set value}) - (\text{current display})$ |
| Error 8 | Measured values fluctuate to much during zero and span calibration | Check if measured values fluctuate excessively during calibration. Infrared component, built-in paramagnetic type O ₂ : If measured values are not stabilized in 60 seconds (change of more than 100 counts is continued) Built-in galvanic cell type O ₂ , Zirconia O ₂ : If measured values are not stabilized in 60 seconds (change of input voltage is continued by more than 100mV) |
| Error 9 | Calibration is abnormal during auto calibration | Error corresponding to No. 4 to No.8 occurs during auto calibration. |
| Error 10 | Output cable connection is improper. | Error occurs if no response is made from the digital output IC. |

Main portions to be checked during error

| Error No. | Main portions to be checked |
|-----------|---|
| Error 1 | Sector rotation, light source, and detector signal on amplifier printed circuit board. |
| Error 2 | See service manual No.17 to 20 in “1) A/D data” on the page 16. Connecting part between detector amplifier board and Main board (cable connector). |
| Error 3 | No. 15 of A/D data in factory mode Voltage between TPVH1- TPVS1 on main printed circuit board |
| Error 4 | See service manual “5. (1) Zero calibration can not be performed”. |
| Error 5 | |
| Error 6 | See service manual “5. (1) Span calibration can not be performed”. |
| Error 7 | |
| Error 8 | See service manual “5. (1) Zero calibration and span calibration can not be performed”. |
| Error 9 | |
| Error 10 | Contact portions between DIO boards (plug-in connector). Contact portions of DIO board and AIO board (cable). |

5. TROUBLESHOOTING AND DATA COLLECTION

(1) Countermeasures against trouble

1) Zero calibration can not be performed

- Check that a specified amount of zero gas is supplied to the analyzer main unit
⇒ Locate a gas leaked portion and remedy.
- Check if detector signal is as specified (see Detector unit.).
⇒ Check the voltage of detector.
 - (1) Record voltage when zero gas is supplied. (Amplifier board TP1 - SC)
 - (2) Check the detector voltage. (Amplifier board DV1 - GND)
- Check the A/D data against the display (see Factory mode and A/D data).
⇒ Check voltage at the Main board. Check the power supply voltage. Record the A/D data when zero gas is supplied.

2) Span calibration can not be performed

- Check that span gas concentration and span concentration value settings are the same.
- Check that specified amount of span gas is supplied to the analyzer main unit.
⇒ Locate a gas leaked portion and remedy.
- Check that zero calibration can be properly performed.
⇒ If zero calibration can not be performed, repeat the procedure “1) Zero calibration can not be performed”.
- Check if detector signal is as specified (see Detector unit.).
⇒ Record voltage when span gas is supplied (to compare with the voltage when zero gas is supplied).
- Check the A/D data against the display (see Factory mode and A/D data).
⇒ Check voltage at the Main board. Check the power supply. Record the A/D data when span gas is supplied.

3) Drift

- Check that specified amount of sampling gas is supplied to the analyzer main unit.
⇒ Locate a gas leaked portion and remedy.
- Check that the cell window, O-ring, detector window and cell inside are not contaminated.
⇒ Clean the cell and window. Replace parts.

4) Readings are high or low too much.

- Check that a large quantity of interference components (moisture and CO₂) is not contained in sampling gas.
⇒ Check the components contained in sampling gases (Ask the user what components are contained in sampling gas).

5) Readings are not increased

- Check that specified amount of sampling gases are supplied to the analyzer main unit.
⇒ Locate a gas leaked portion and remedy.
- Check that zero and span calibration can be performed.
⇒ If possible, check for sampling gas (related to sampling gas) and take remedies.
⇒ If not possible, check the item 1) and 2).

(2) Data sampling at trouble

When trouble occurs, be sure to sample the following data.

In the case of the trouble in connection with the characteristic, please sample data (please surely sample data to a factory at the time of an inquiry).

Supply the gas given in Table and sample the measured value of measurement screen, sensor input values in maintenance mode.

| Supply gas | Gas concentration, composition | | Span calibration concentration set value | Measurement display | Sensor input value in maintenance mode |
|-------------|--------------------------------|--|--|---------------------|--|
| Zero gas | Range 1 | | | | |
| | Range 2 | | | | |
| Span gas | Range 1 | | | | |
| | Range 2 | | | | |
| 2°C Wet gas | | | | | |
| Sample gas | | | _____ | Range 1 | |
| | | | | Range 2 | |

- If there is no Range 2, the part of a Range 2 is entry needlessness.
- If trouble occurs to other components, sample data for each component.
- If trouble occurs to O₂ sensor, sample zero calibration concentration set values together with span calibration concentration set value.

Check each coefficient by “Coefficient” in the factory mode.

| Coefficient | Component | Range value | | Zero coefficient | Span coefficient |
|-------------|-----------|-------------|--|------------------|------------------|
| Ch1 | | Range 1 | | | |
| | | Range 2 | | | |
| Ch2 | | Range 1 | | | |
| | | Range 2 | | | |
| Ch3 | | Range 1 | | | |
| | | Range 2 | | | |

- Sampling system diagram
If sampling system diagram is prepared, report the drawing number.
If sampling system diagram is not prepared, report the sketch.

For other troubles, sample various data about necessary setting items.

6. ADJUSTMENT IN HEAT TREATMENT FURNACE

What is the adjustment in heat treatment furnaces?

If, in plant gases to be measured actually, a large amount of other lower-molecular-weight gases than nitrogen (N_2) such as hydrogen (H_2), or a large amount of other higher-molecular-weight gases than nitrogen (N_2) such as argon (Ar) are contained, including the measuring components, it is known that the calibration curve (output performance to gas concentration) of gas analyzers will be affected (pressure broadening).

In such a case, analyzer is adjusted with gases similar to plant gas compositions in manufacturing (adjustment by scale gas). After this adjustment, the analyzer is checked the calibration curve with N_2 balance gas (calibration curve by check gas). Graphs with these calibration curves drawn are attached to products to be supplied.

Since measurement in a heat treatment furnace has much gas of such composition, it is considering as the adjustment for heat treatment furnaces.

In order to perform exact measurement, there are two methods in span calibration:

Composition of the standard gas for span calibration used for each method and its method are explained using an example:

For the standard gas for zero calibration, use dry N_2 in any case so that zero point will not be affected.

<Example>

Assume that a 0 – 1% CO_2 meter of the infrared ray gas analyzer measures CO_2 contained in plant gases.

When plant gases are composed of 0.5% CO_2 , 23% CO, 30% H_2 , 0.2% CH_4 and 46.3% N_2 , either of the following is used as the span calibration standard gas.

| | Standard gas type | Composition of standard gas | Method for span adjustment |
|---|---|--|-------------------------------------|
| 1 | Standard gas with the same composition as plant gases (scale gas) | 0.9% to 1% CO_2 23% CO, 30% H_2 , remainder is N_2 * | Perform span calibration directly. |
| 2 | Check gas | 0.9% to 1% CO remainder is N_2 | Perform span calibration indirectly |

* A small amount of gas like 0.2% CH_4 with little effect on span calibration may be excluded from the standard gas.

(1) Method for span calibration by standard gas with the same composition as plant gas

When using the standard gas with the same composition as plant gases given in 1, calibration can be performed without correction, as an error in calibration curve does not occur.

- 1) Set CO_2 concentration to span calibration concentration set value.
- 2) Perform span calibration by using the operation key.

(2) Method for span calibration by check gas

The method for span calibration by use of check gas (give in 2) is explained based on the example.

(Since span calibration has an error of calibration curve, preset a calibration indication on the calibration curve graph attached to this analyzer for indirect calibration.)

- 1) The following calibration curve graph is attached to the test results for the product. In graph, the calibration curve by the scale gas (that is similar to plant gas and determines scales of this analyzer) and the calibration curve by the check gas that is adjusted by the scale gas (gas of simple composition of N₂ balance gas to facilitate the analyzer check) are drawn.

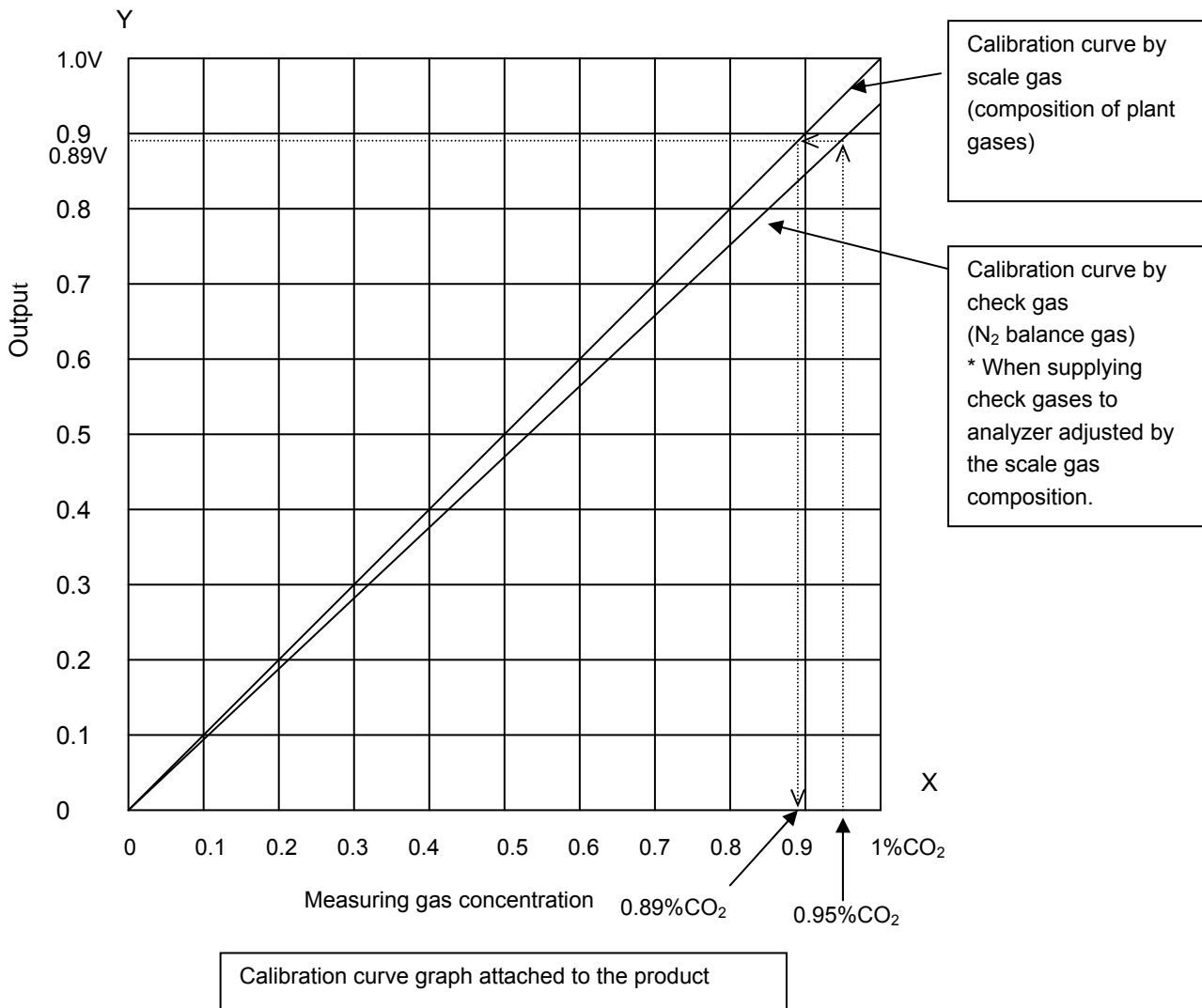

- 2) When using 0.95% CO₂ and remainder N₂ (check gas) as calibration gas, In graph, a point of 0.95% on X-axis should be stretched to upward, draw a line toward Y-axis from the cross point with the check gas calibration curve. From the cross point with calibration curve on the scale gas composition, 0.89% or equivalent values can be obtained.
- 3) Set this point (0.89%) to the span calibration concentration of the calibration concentration set value.
- 4) Supply 0.95% check gas to perform span calibration. Then, the concentration value is corrected to 0.89%. Measurement suited to actual plants can be performed by this error correction of calibration curve.

7. Moisture interference adjustment (NO, SO₂ only)

Purpose : Adjust the light control plate in between the three layer detector so that moisture interference becomes close to zero.

Procedure : (1) To start adjustment, set the light control plate at the same height (10 to 15mm upper than (c): upper end of the fixing plate) as in the right figure (a).

- (2) Enter "Maintenance mode", "1.Sensor Input".
- (3) Flow zero gas and gas contained water of 2°C (N₂ balance) to read the count value of each gas. Respectively replace the read values (in NO, SO₂ component) of Zero with Z_a and Moisture with H_a.

(4) Set the light control plate at the same height (1 to 6mm lower than (c): upper end of the fixing plate) as in the right figure (b).

- (5) Flow the gas in the same manner in (3) to read the count value of each gas. Respectively replace the read values of Zero with Z_b and Moisture with H_b.

(6) Calculate the Zero point, Z_x (count value) as following.

$$Z_x = \left(\frac{(Z_b \times H_a) - (Z_a \times H_b)}{(Z_b - Z_a) - (H_b - H_a)} \right)$$

(7) Move the light control plate up and down while flowing zero gas, and adjust its position so that the value becomes equal to Z_x calculated in (6).

When the position of the panel is set, fasten it with fixing screw.

- (8) After Zero/Span calibration, flow water of 2°C, and check that a deviation is within 1%FS.
- (9) After confirmation in (8), perform paint lock of the fixing screw of the light control panel.

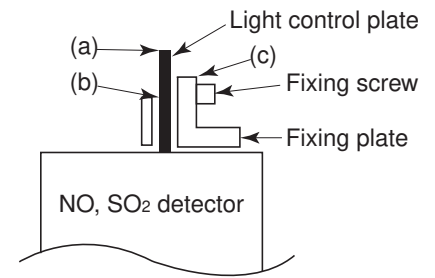

APPENDIX 1. MEASURING PRINCIPLE DIAGRAM

Principle Diagram of Infrared Type Measurement (NO, SO₂, CO₂, CO, CH₄)

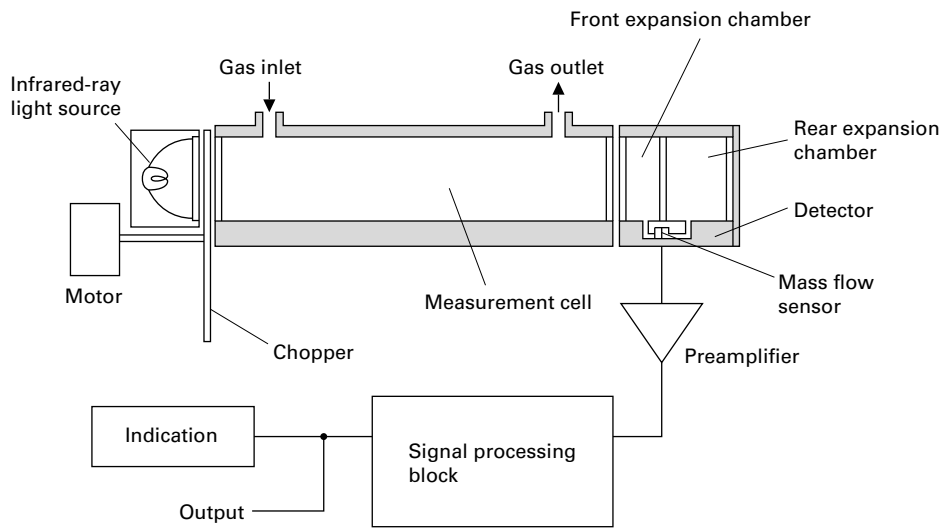

Principle Diagram of Magnetic Force Type Measurement (O₂)

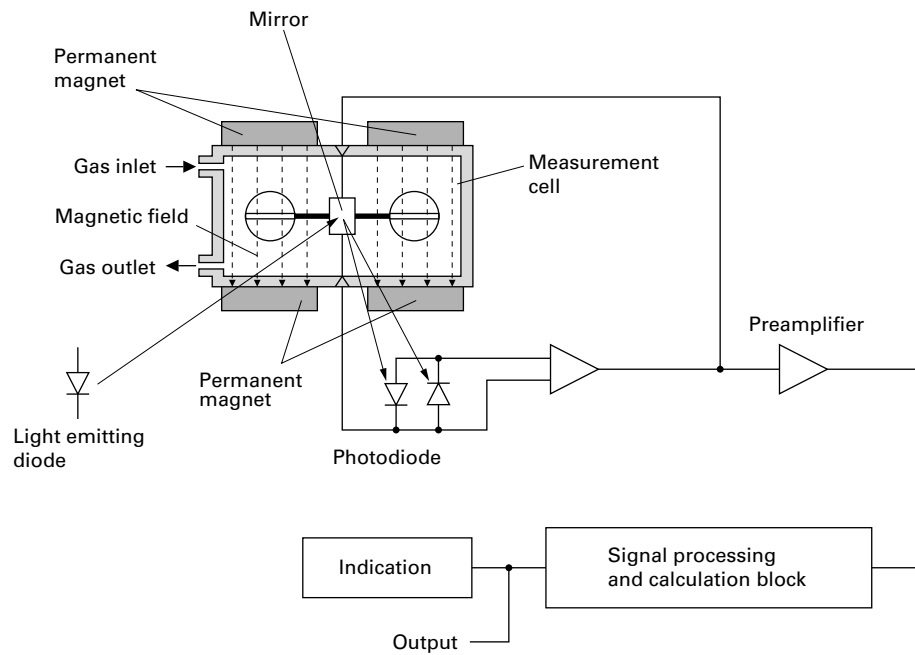

Principle Diagram of Galvanic cell Type Measurement (O₂)

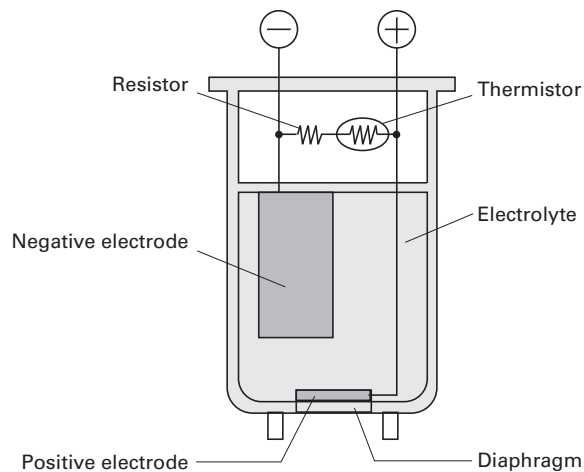

APPENDIX 2. SOFT FLOW DIAGRAM

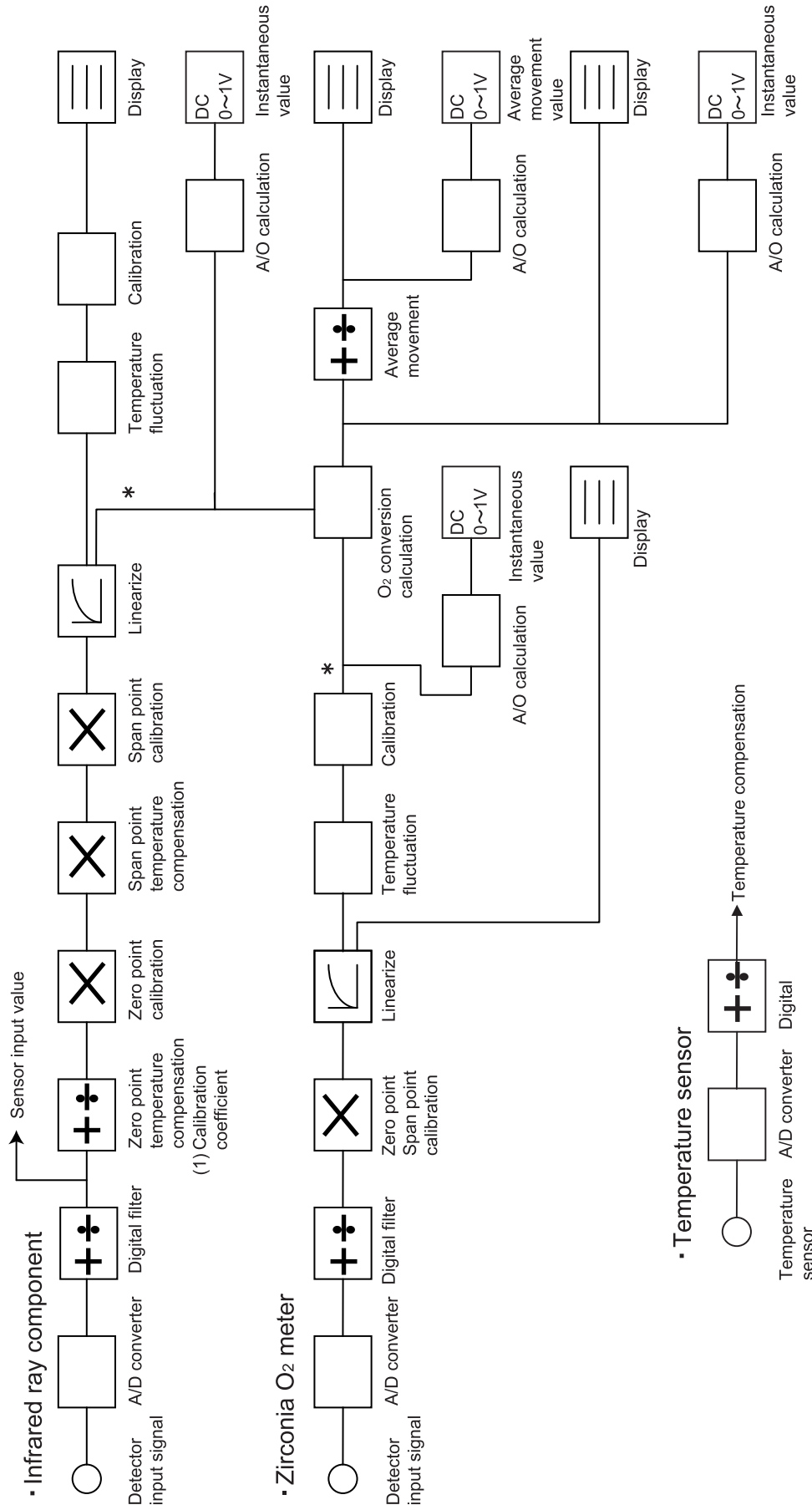

Note 1) Asterisk mark * indicates "Hold point".
Computation is stopped during the hold.

APPENDIX 3. PRINTED BOARD DIAGRAM

Main board

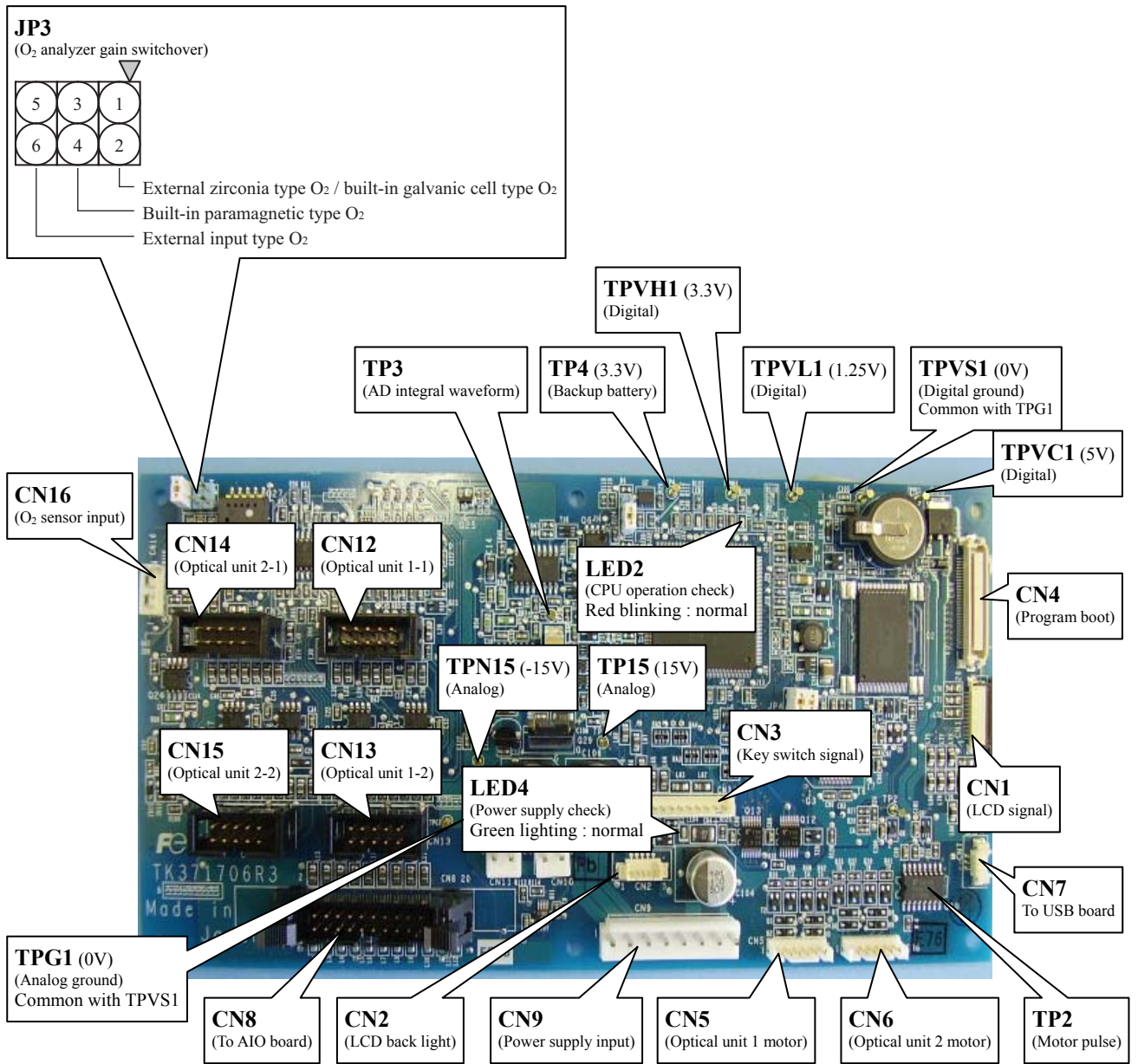

AIO board

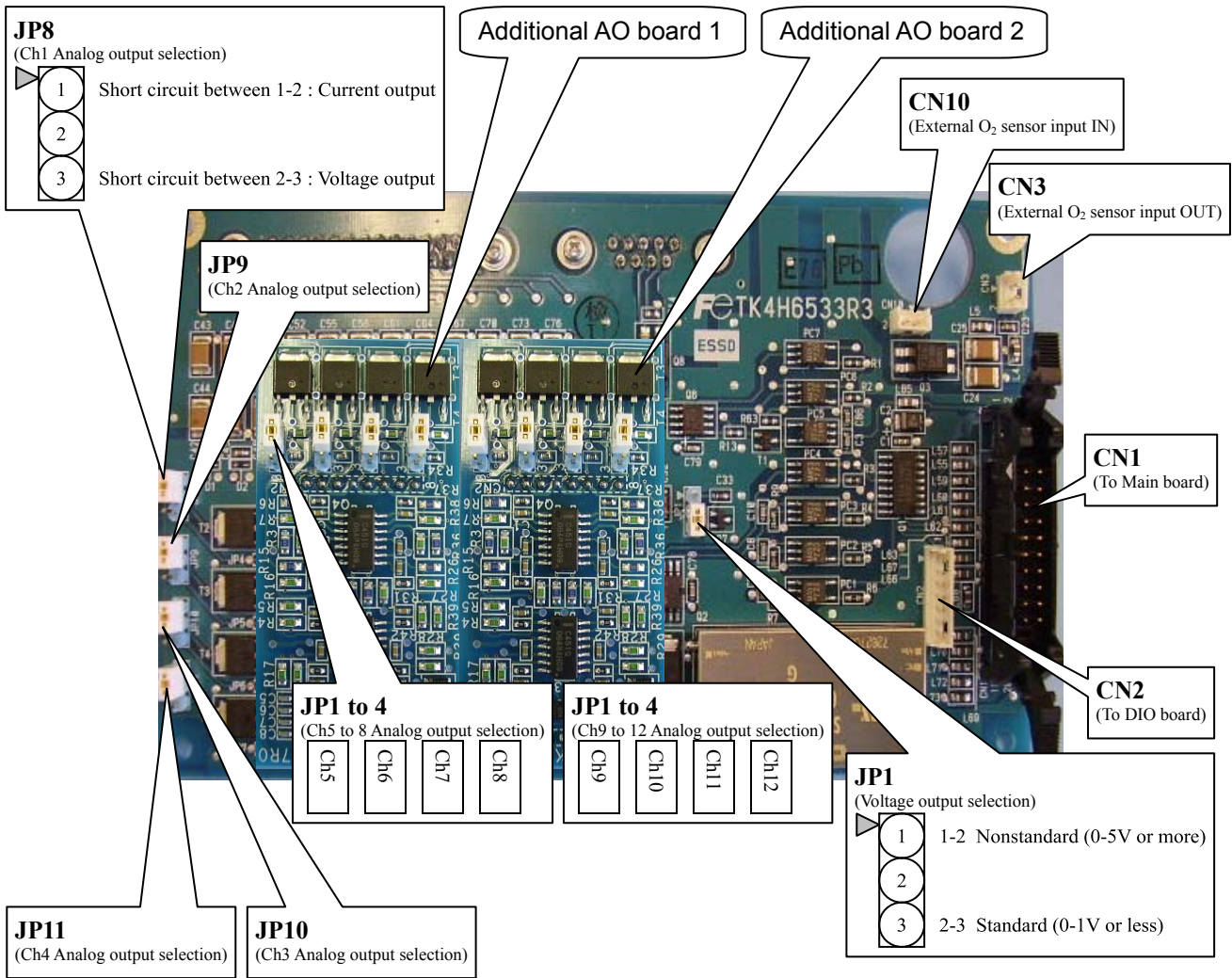

Amplifier board

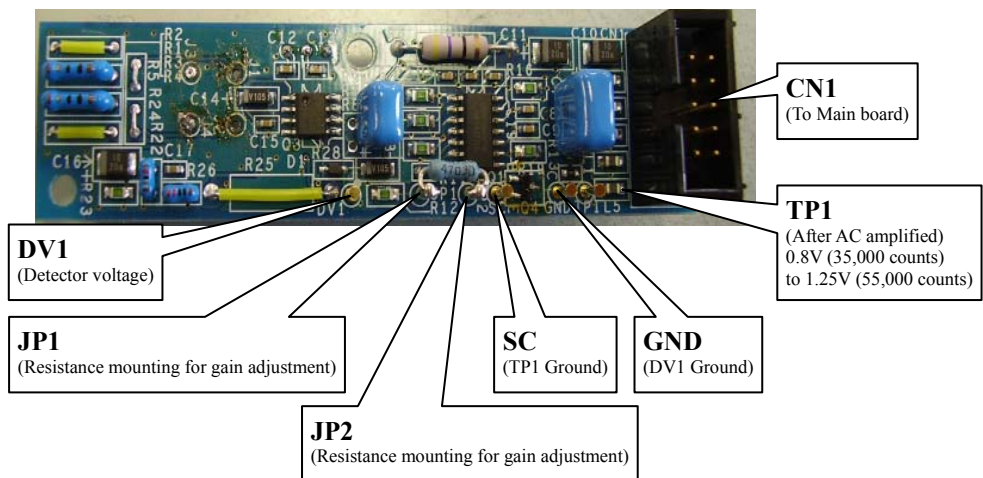

 Fuji Electric Co., Ltd.

**International Sales Div
Sales Group**

Gate City Ohsaki, East Tower, 11-2, Osaki 1-chome,
Shinagawa-ku, Tokyo 141-0032, Japan
<http://www.fujielectric.com>
Phone: 81-3-5435-7280, 7281 Fax: 81-3-5435-7425
<http://www.fujielectric.com/products/instruments/>
