



Service Manual

# INFRARED GAS ANALYZER

TYPE: ZPA, ZPB, ZPG

# PREFACE

---

This service manual describes the infrared gas analyzer (Type: ZPA, ZPB, ZPG).

This service manual is intended for use with the instruction manual to help you in understanding maintenance and inspection for the infrared gas analyzer (ZPA, ZPB, ZPG). However, the basic operation of the analyzer is not covered in this manual.

This manual provides information about the parameter settings in the factory mode, adjustment and precautions for parts replacement, and troubleshooting for the infrared gas analyzer (ZPA, ZPB, ZPG) which are not covered in the instruction manual.

This service manual gives you useful hints to take immediate remedy for after-sales service.

- First read the instruction manual and service manual carefully until an adequate understanding is acquired, and then proceed to installation, operation and maintenance of the gas analyzer. Wrong handling may cause an accident or injury.
- The specifications of this analyzer will be changed without prior notice for further product improvement.
- Modification of this gas analyzer is strictly prohibited unless a written approval is obtained from the manufacturer. Fuji Electric will not bear any responsibility for a trouble caused by such a modification.

Manufacturer: Fuji Electric Co., Ltd.  
Type: Described in Fuji Electric's company nameplate on main frame  
Date of manufacture: Described in Fuji Electric's company nameplate on main frame  
Product nationality: Japan

©Fuji Electric Co., Ltd. 2013

## Request

- It is prohibited to transfer part or all of this manual without Fuji Electric's permission in written format.
- Description in this manual will be changed without prior notice for further improvement.

Issued in June, 2013  
Rev. 1st edition October, 2013  
Rev. 2nd edition July, 2018

# CONTENTS

---

PREFACE.....	i
TABLE OF CONTENTS .....	ii
SAFETY INSTRUCTIONS .....	iv
1. STRUCTURE.....	1
1.1 Analyzer* .....	1
1.2 Optical unit.....	3
1.3 Wiring diagram .....	5
1) ZPA.....	5
2) ZPB.....	6
3) ZPG.....	7
1.4 Internal piping diagram .....	8
1) ZPA.....	8
2) ZPB.....	9
3) ZPG.....	10
2. MAINTENANCE AND INSPECTION .....	11
2.1 Light source unit* .....	11
2.2 Sector motor and sector.....	12
2.3 Cell, cell window, and O-ring .....	12
2.4 Detector unit (excluding O <sub>2</sub> sensor)* .....	13
2.5 Built-in O <sub>2</sub> sensor (magnetic type).....	14
2.6 Built-in O <sub>2</sub> sensor (galvanic type).....	15
2.7 PCB .....	15
1) Main board.....	15
2) AIO board.....	16
3) Main power supply board .....	16
4) Light source power supply board .....	16
2.8 LCD.....	16
2.9 Switched-mode power supply (SMPS) .....	17
2.10 Operation keys .....	18
2.11 Solenoid valve* .....	19
2.12 Filter .....	19
3. FACTORY MODE.....	20
3.1 How to go to factory mode.....	20
3.2 Zero limit.....	21
3.3 Range limit.....	22
3.4 Calibration coefficient.....	23
3.5 A/D conversion value* .....	24
4. ERROR CRITERIA* .....	25
5. TROUBLESHOOTING .....	27
6. ADJUSTMENT FOR HEAT TREATMENT FURNACES .....	29
6.1 Method for span calibration by standard gas with the same composition as plant gas .....	29
6.2 Method for span calibration by check gas.....	30
7. MOISTURE INTERFERENCE ADJUSTMENT* .....	31

---



APPENDIX 1. MEASURING PRINCIPLE DIAGRAM .....	32
APPENDIX 2. DATA FLOW DIAGRAM .....	33
APPENDIX 3. PCB COMPONENT LAYOUT .....	34
Main board .....	34
AIO board.....	35
Amplifier board .....	35
Main power board.....	36
Light source power board* .....	36



\* Those marked with asterisk are the items of which detail is not common among ZPA, ZPB, and ZPG. Other items are common.

# SAFETY INSTRUCTIONS

First of all, read this “Caution on safety” carefully, and then use the analyzer in the correct way.



- The cautionary descriptions listed here contain important information about safety, so they should always be observed. Those safety precautions are ranked in 3 levels, “DANGER”, “CAUTION” and “PROHIBITION”.



 <b>DANGER</b>	Wrong handling may cause a dangerous situation, in which there is a risk of death or heavy injury.
 <b>CAUTION</b>	Wrong handling may invite a dangerous situation, in which there is a possibility of medium-level trouble or slight injury or only physical damage is predictable.
 <b>PROHIBITION</b>	Items which must not be done are noted.

<b>Installation and Transport</b>	
 <b>DANGER</b>	<ul style="list-style-type: none"> <li>• This unit is not explosion-proof type. Do not use it in a place with explosive gases to prevent explosion, fire or other serious accidents.</li> </ul>
 <b>CAUTION</b>	<ul style="list-style-type: none"> <li>• For installation, observe the rule given in the instruction manual and select a place where the weight of gas analyzer can be endured. Installation at an unsuited place may cause turnover or fall and there is a risk of injury.</li> <li>• For lifting the gas analyzer, be sure to wear protective gloves. Bare hands may invite an injury.</li> <li>• Before transport, fix the casing so that it will not open. Otherwise, the casing may be separated and fall to cause an injury.</li> <li>• During installation work, care should be taken to keep the unit free from cable chips or other foreign objects. Otherwise, it may cause fire, trouble or malfunction of the unit.</li> <li>• As the analyzer is heavy, the carry of the gas analyzer should be done by at least two person to avoid pain or injury.</li> </ul>

<b>Piping</b>	
 <b>DANGER</b>	<p><b>In piping, the following precautions should be observed. Wrong piping may cause gas leakage.</b></p> <p><b>If the leaking gas contains a toxic component, there is a risk of serious accident being induced.</b></p> <p><b>Also, if combustible gas is contained, there is a danger of explosion, fire or the like occurring.</b></p> <ul style="list-style-type: none"> <li>• Connect pipes correctly referring to the instruction manual.</li> <li>• Exhaust should be led outdoors so that it will not remain in the locker and installation room.</li> <li>• Exhaust from the analyzer should be relieved in the atmospheric air in order that an unnecessary pressure will not be applied to the analyzer. Otherwise, any pipe in the analyzer may be disconnected to cause gas leakage.</li> <li>• For piping, use a pipe and a pressure reducing valve to which oil and grease are not adhering. If such a material is adhering, a fire or the like accident may be caused.</li> </ul>

<b>Wiring</b>	
 <b>CAUTION</b>	<ul style="list-style-type: none"> <li>• Wiring work must be performed with the main power set to OFF to prevent electric shocks.</li> <li>• Enforce construction of class-3 grounding wire by all means. If the specified grounding construction is neglected, a shock hazard or fault may be caused.</li> <li>• Wires should be the proper one meeting the ratings of this analyzer. If using a wire which cannot endure the ratings, a fire may occur.</li> <li>• Be sure to use a power supply of correct rating. Connection of power supply of incorrect rating may cause fire.</li> </ul>

<b>Operation</b>	
 <b>DANGER</b>	<ul style="list-style-type: none"> <li>• For correct handling of calibration gas or other reference gases, carefully read their instruction manuals beforehand. Otherwise, carbon monoxide or other hazardous gases may cause an intoxication particularly.</li> </ul>
 <b>CAUTION</b>	<ul style="list-style-type: none"> <li>• Before leaving unused for a long time or restarting after left at such a status for an extended length of time, follow the directions of each instruction manual because they are different from normal starting or shutdown. Otherwise, the performance may be poor and accidents or injuries may be caused.</li> <li>• Do not operate the analyzer for a long time with its door left open. Otherwise, dust, foreign matter, etc. may stick on internal walls, thereby causing faults.</li> <li>• Stop the gas analyzer while the analyzer is slid out from the rack. Otherwise, the gas analyzer may drop and cause injury.</li> <li>• Do not open the cover of the gas analyzer during operation. If you touch something inside, you may get burned or electrical shock.</li> </ul>
 <b>PROHIBITION</b>	<ul style="list-style-type: none"> <li>• Do not allow metal, finger or others to touch the input/output terminals in the analyzer. Otherwise, shock hazard or injury may occur.</li> <li>• Do not smoke nor use a flame near the gas analyzer. Otherwise, a fire may be caused.</li> <li>• Do not allow water to go into the gas analyzer. Otherwise, hazard shock or fire in the analyzer may be caused.</li> </ul>

<b>Maintenance and Check</b>	
 <b>DANGER</b>	<ul style="list-style-type: none"> <li>• When doors are open during maintenance or inspection, be sure to purge sufficiently the inside of the gas analyzer as well as the measuring gas line with nitrogen or air, in order to prevent poisoning, fire or explosion due to gas leak.</li> </ul>
 <b>CAUTION</b>	<p><b>Be sure to observe the following for safe operation avoiding the shock hazard and injury.</b></p> <ul style="list-style-type: none"> <li>• Remove the watch and other metallic objects before work.</li> <li>• Do not touch the analyzer with wet-handed.</li> <li>• If the fuse is blown, eliminate the cause, and then replace it with the one of the same capacity and type as before. Otherwise, shock hazard or fault may be caused.</li> </ul>

---

**Others**



**CAUTION**

- If the cause of any fault cannot be determined despite reference to the instruction manual, be sure to contact your dealer or Fuji Electric's technician in charge of adjustment. If the analyzer is disassembled carelessly, you may have a shock hazard or injury.
- Do not use a replacement part other than specified by the analyzer maker. Otherwise, adequate performance will not be provided. Besides, an accident or fault may be caused.
- Replacement parts such as a maintenance part should be disposed of as incombustibles.

# 1. STRUCTURE

## 1.1 Analyzer

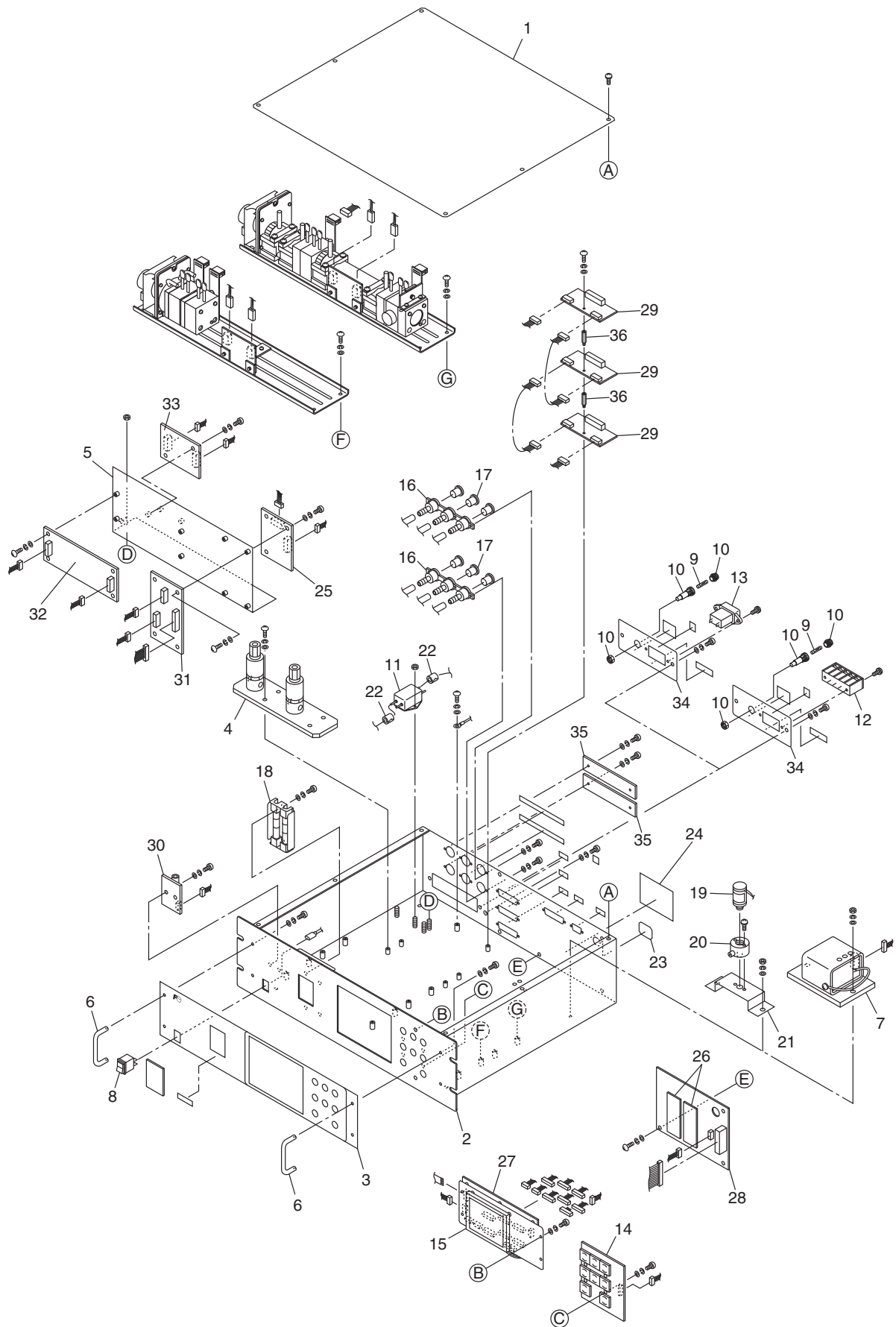

Part No.	Part name	Mount or not		
		ZPA	ZPB	ZPG
1	Case ass'y			
2	Base			
3	Front panel ass'y			
4	Solenoid Valve (SV) ass'y	none		
5	Power supply mounting plate			
6	Handle			
7	Paramagnetic type O <sub>2</sub> sensor unit			
8	Power switch			
9	Pipe fuse			
10	Fuse holder			
11	Noise filter			
12	Power inlet terminal			
13	Power inlet			
14	Key board			
15	LCD			
16	Triple gas port unit			
17	Dust cap			
18	Flow checker ass'y	none		
19	Galvanic cell type O <sub>2</sub> sensor unit			
20	Galvanic cell type O <sub>2</sub> sensor socket			
21	Galvanic cell type O <sub>2</sub> sensor plate			
22	Ferrite core			
23	Filling seal			
24	Specification name plate			
25	SSW board	none		
26	AO board			
27	Main board			
28	AIO board			
29	DIO board			
30	Commu board			
31	Main power board			
32	Power supply 1			
33	Power supply 2	none		
34	Power inlet (terminal) mounting plate			
35	Filling plate		none	none
36	Hexagnal spacer			

## 1.2 Optical unit

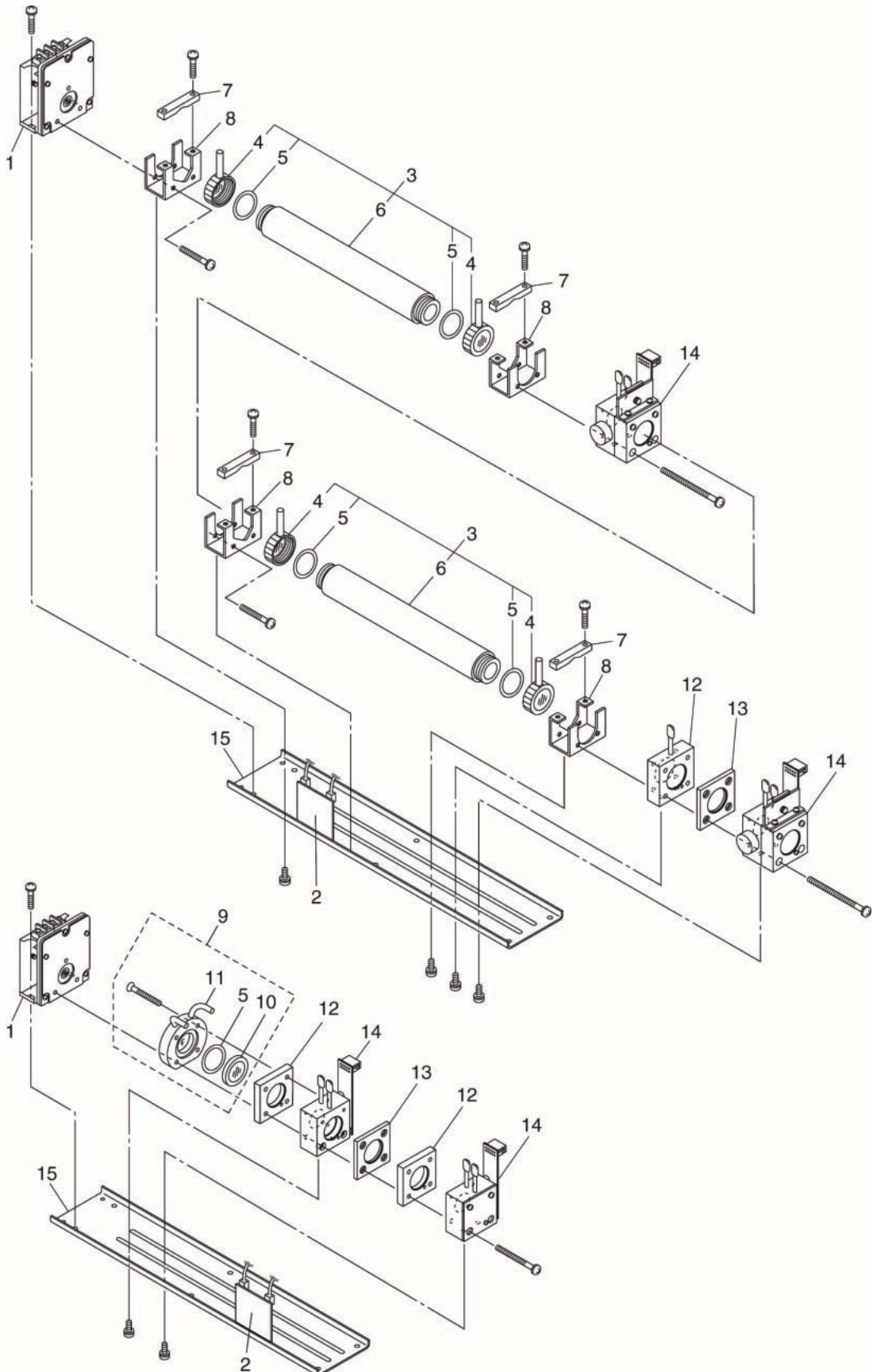

---

Part No.	Part name	Part No.	Part name
1	Light source unit	8	Cell fixing block
2	LS power board	9	Block cell ass'y
3	Pipe cell ass'y	10	Window ass'y
4	Window ass'y	11	Block cell
5	O ring	12	Gas filter
6	Pipe cell	13	Filter
7	Cell mounting	14	Detector unit
		15	Base plate



## 2) ZPB

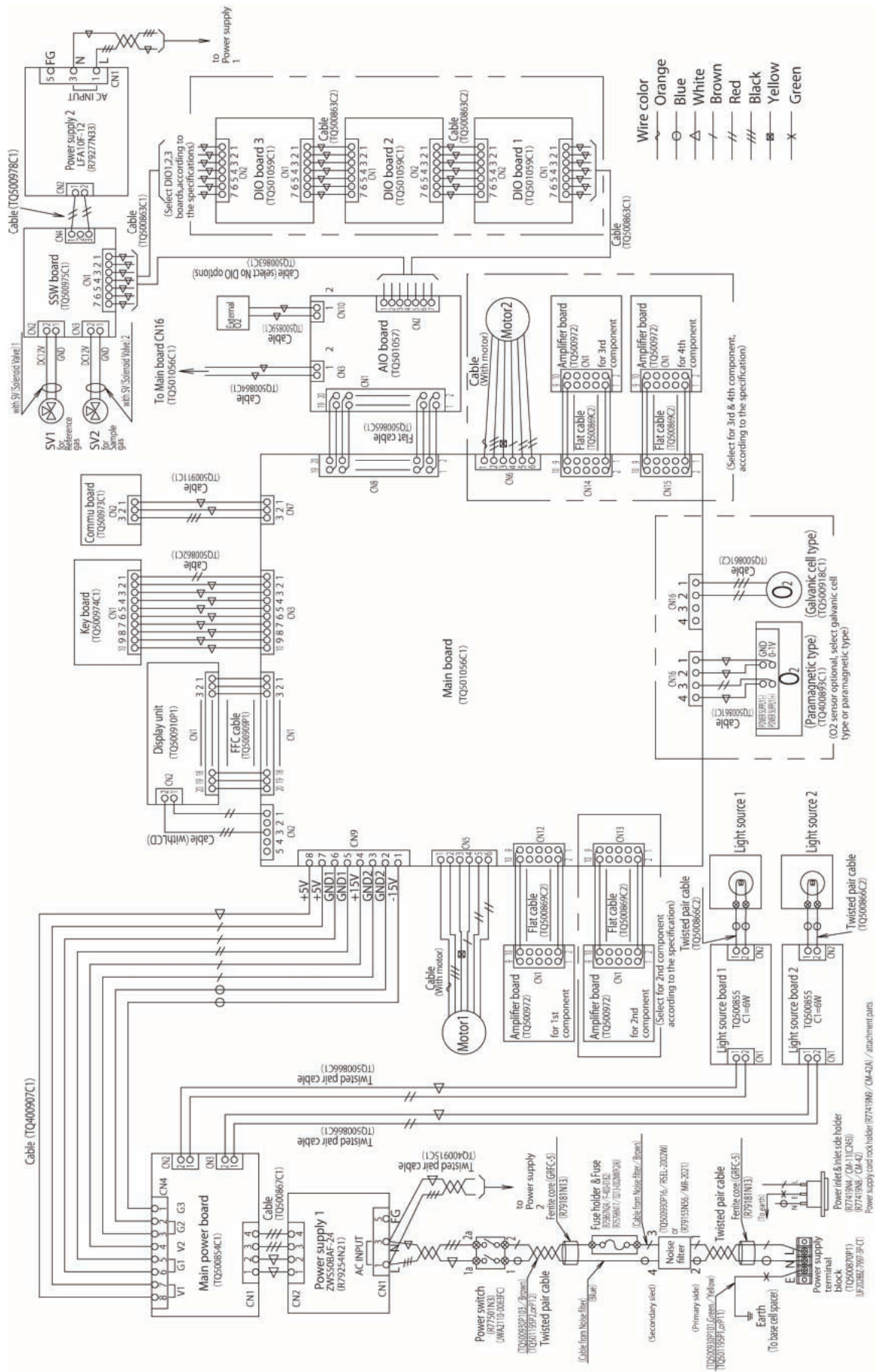

### 3) ZPG

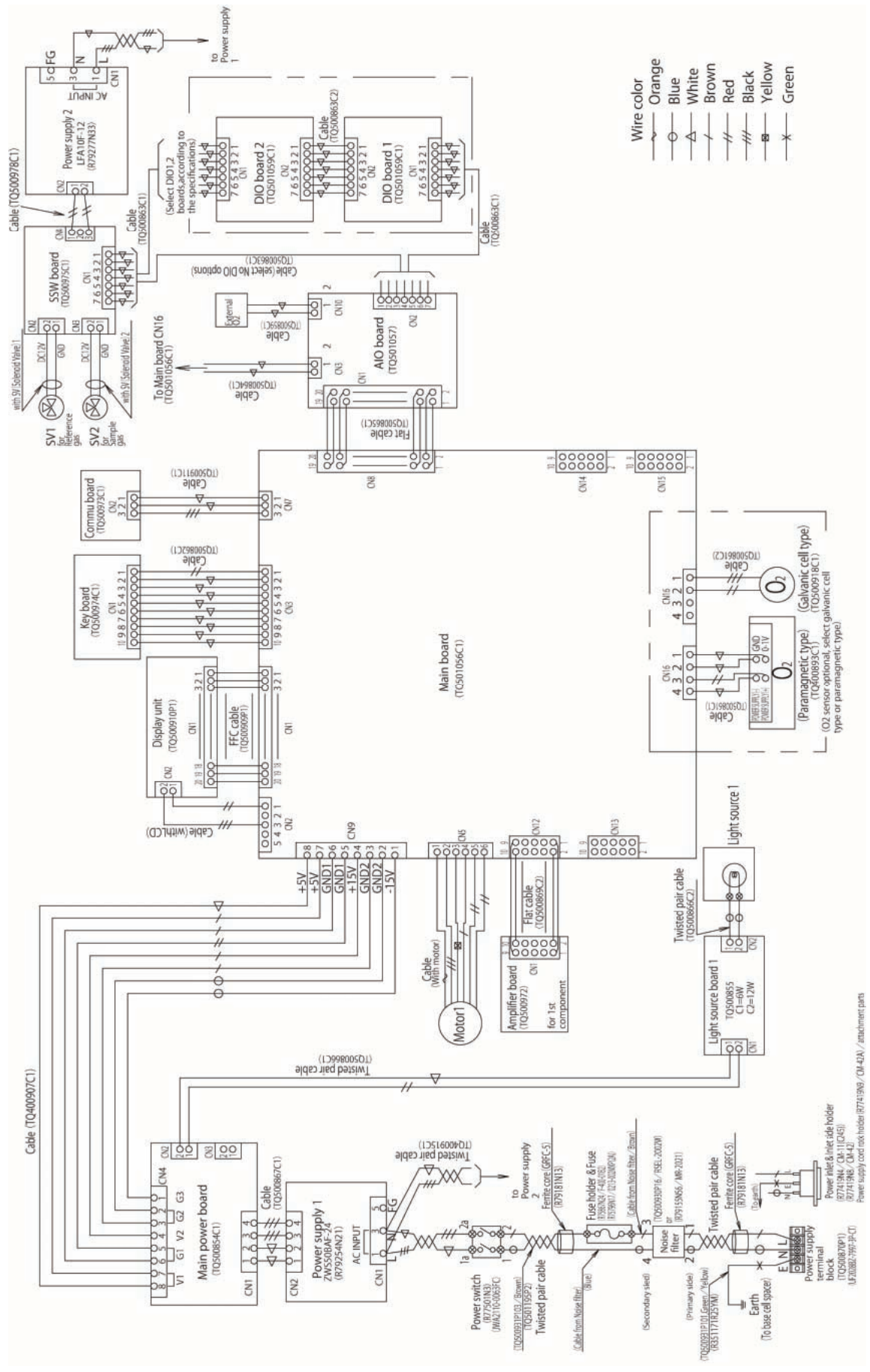

# 1.4 Internal piping diagram

## 1) ZPA

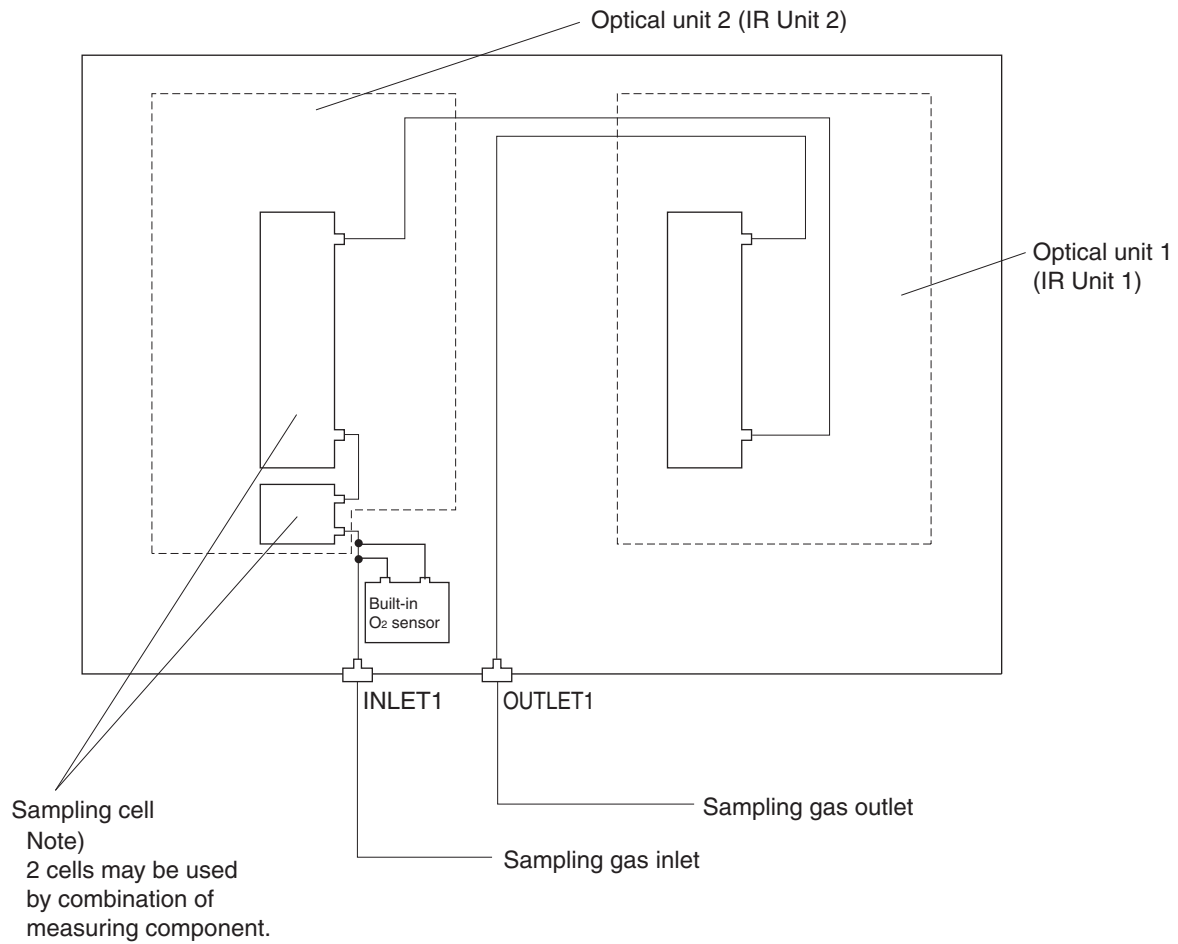

Gas components measured by each optical unit

No. of gases to be measured	Gases to be measured	Optical unit 1	Optical unit 2
1	NO, SO <sub>2</sub> , CO <sub>2</sub> , CO, or CH <sub>4</sub>	One of the left	None
2	CO <sub>2</sub> and CO	CO <sub>2</sub> and CO	None
2	NO and CO	NO	CO
2	NO and SO <sub>2</sub>	NO	SO <sub>2</sub>
3	NO, SO <sub>2</sub> , and CO	NO	SO <sub>2</sub> and CO
4	NO, SO <sub>2</sub> , CO <sub>2</sub> , and CO	NO and CO	SO <sub>2</sub> and CO <sub>2</sub>

## 2) ZPB

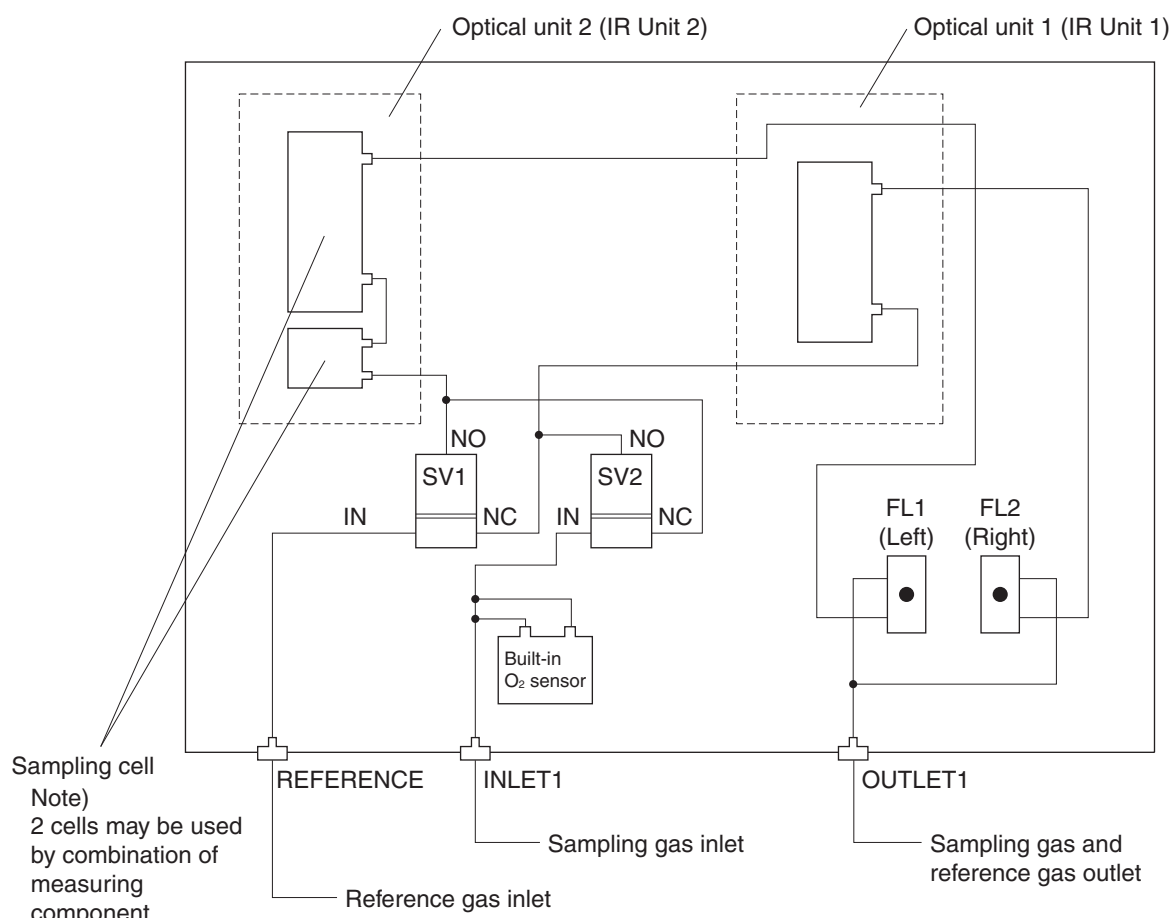

Gas components measured by each optical unit

No. of gases to be measured	Gases to be measured	Optical unit 1	Optical unit 2
1	NO, SO <sub>2</sub> , CO <sub>2</sub> , or CO	One of the left	None
2	CO <sub>2</sub> and CO	CO <sub>2</sub> and CO	None
2	NO and CO	NO	CO
2	NO and SO <sub>2</sub>	NO	SO <sub>2</sub>
3	NO, SO <sub>2</sub> , and CO	NO	SO <sub>2</sub> and CO
4	NO, SO <sub>2</sub> , CO <sub>2</sub> , and CO	NO	SO <sub>2</sub> , CO <sub>2</sub> , and CO

### 3) ZPG

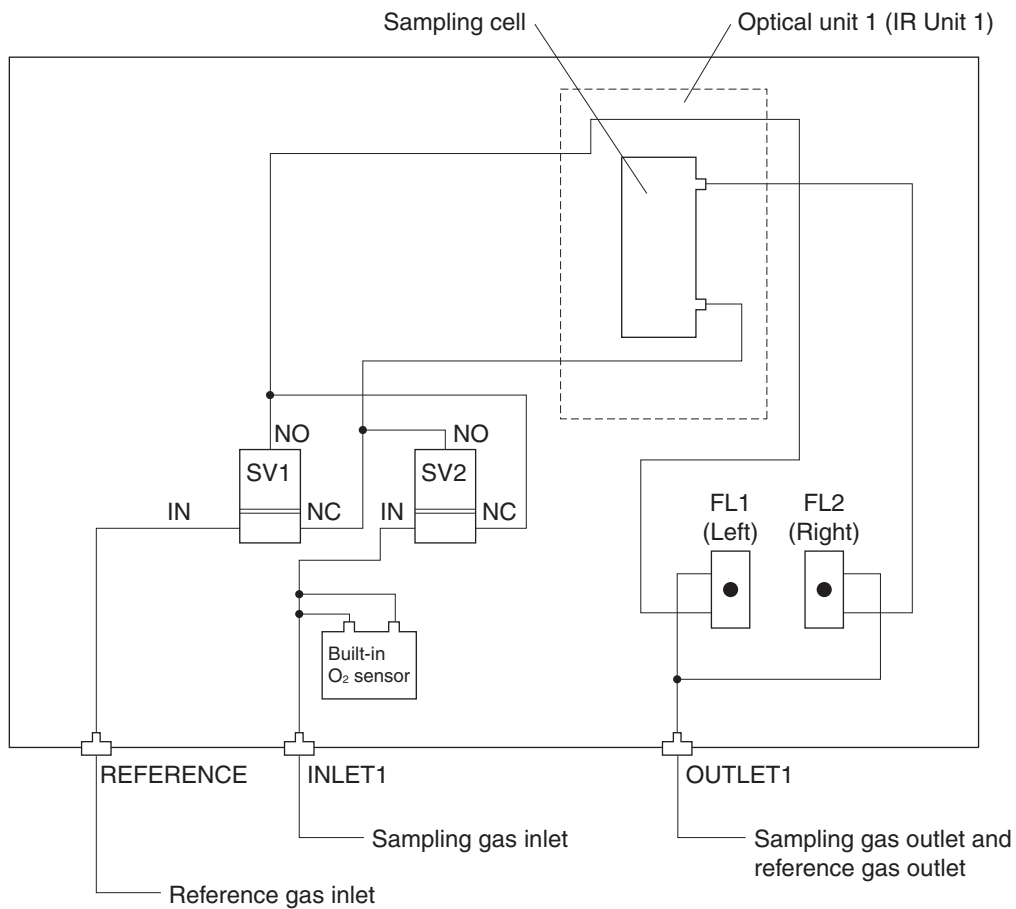

Gas components measured by each optical unit

No. of gases to be measured	Gases to be measured	Optical unit 1	Optical unit 2
1	NO, SO <sub>2</sub> , CO <sub>2</sub> , or CO	One of the left	None

## 2. MAINTENANCE AND INSPECTION

### 2.1 Light source unit

- Recommended replacement cycle:
  - ZPA and ZPB : 5 years
  - ZPG : 2 years
- Possible errors caused by the deterioration of this part:

- a) Short circuit or disconnection of the hot wires of the light source unit

Symptom: Error 1, display of dashes (----)

Check:

1. Turn off the analyzer.
2. Disconnect the power cables from of the light source unit.
3. Measure the resistance between two-pin terminals of the light source unit.

If the resistance meets the following requirements, the light source unit is normal.

ZPA, ZPB, ZPG (CO <sub>2</sub> analyzer only)	36.5±2 Ω
ZPG (excluding CO <sub>2</sub> analyzer)	6.2±0.3 Ω

If the resistance is infinite, the wires are damaged.

Note that if the resistance is smaller than the above criteria, the reading drifts towards minus direction.

- b) Filler gas leakage from the light source unit

Symptom: Unstable indication

Check: If, regardless there is no abnormality in any parts other than the light source, the measured value output greatly fluctuates or drifts affected by the ambient air, it may be caused by the leakage of the filler gas of the light source.

- Replacement

1. Disconnect a) the wires from two-pin terminals and b) the motor connector.
2. Remove two screws used to join the light source unit and the base plate.
3. Replace the light source unit.
4. Carry out zero calibration and span calibration.

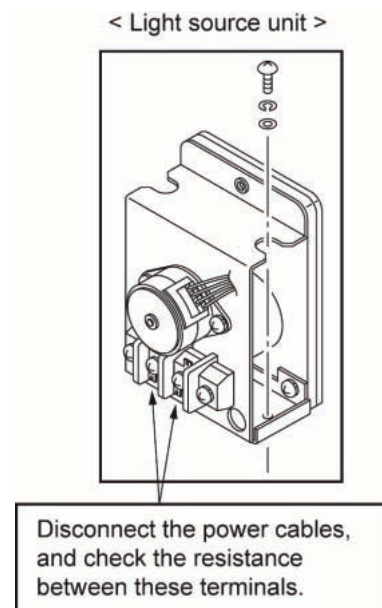

---

## 2.2 Sector motor and sector

- Recommended replacement cycle:
  - ZPA and ZPB : 5 years
  - ZPG : 2 years
- Possible errors caused by the deterioration of this part:
  - a) Stop of motor rotation
    - Symptoms: Error 1, display of dashes (----)
    - Check: Turn on the analyzer, and check that the motor shaft rotates.
  - b) Unstable rotation
    - Symptoms: Error 1, reading fluctuation, or display of dashes (----)
    - Check: Turn on the analyzer, and check that you hear no abnormal noise from the motor, for example, metallic rubbing noise or rattling noise. If there is no abnormal noise, remove the light source unit from the base plate, and turn on the analyzer to directly check that the motor shaft and the sector rotate.
- Replacement
  1. Disconnect a) the wires from two-pin terminals and b) the motor connector.
  2. Remove two screws used to join the light source unit and the base plate.
  3. Replace the light source unit.
  4. Carry out zero calibration and span calibration.

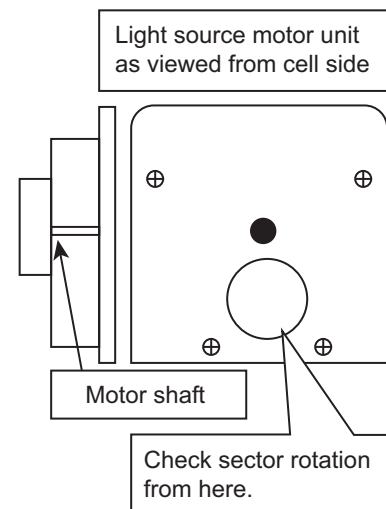

## 2.3 Cell, cell window, and O-ring

- Lifespan and recommended replacement period:

Cell and cell window can be used for years unless they are seriously contaminated or corroded. O-ring should be replaced every two years.
- Possible troubles occur on this part:
  - a) Contamination of cell and/or cell window
    - Symptoms: display of dashes (---), drift, calibration error
    - Check: Disassemble the cell, and check the contamination inside the cell.
  - b) Break of the cell window
    - Symptoms: the reading won't change, slow response, calibration error, reading fluctuation
    - Check: visually check the cell window.
- Remedies:

Cell: clean the cell. Refer to the instruction manual on how to clean the cell. If the deposits are not removed or the cell is heavily corroded, replace the cell.

Cell window: clean the window. If the window is heavily contaminated or broken, replace it.
- Replacement:

Refer to the instruction manual. After cleaning, carry out zero and span calibration, and check the response speed.

## 2.4 Detector unit (excluding O<sub>2</sub> sensor)

- Recommended replacement cycle:  
5 years

- Possible troubles occur on this part:

- a) Degraded sensitivity due to filler gas leakage

Symptoms: calibration error, large fluctuation of the reading

Check: Access Maintenance Mode > Sensor Input Value. Check the count for each component. If the light source works properly and the cell is not contaminated, the count during zero gas flow should be between 35,000 and 80,000 (ZPA) or between 350,000 and 800,000 (ZPB and ZPG). If the count is lower than 30,000 (ZPA) or 300,000 (ZPB and ZPG), the sensitivity of the analyzer may be degraded.

- b) Damage of the mass flow sensor

Symptoms: display of dashes (----), Error 1

Check:

1. Turn off the analyzer.
2. Disconnect the connector on the detector unit.
3. Measure the resistance J1–J4 and the resistance J2–J3 of the amp board on the detector unit.

The resistances shall be between 57 ohm and 63 ohm. If the resistance is greater than the above range, it means the sensor element is damaged.

Do not use an ohmmeter through which an electric current of 2 mA or greater passes. The element may be damaged.

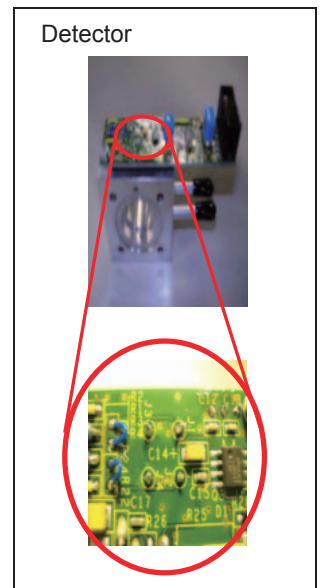

- c) Detector voltage control error

Symptoms: calibration error, large fluctuation of the reading

Check: Measure the voltage between the terminals DV1 and GND on the AMP board.

The following table shows the allowable voltages for each detector.

Check terminal	Check voltage	Detector type(*1)
DV1-GND (detector voltage)	+6.5±0.05 V	CO-L, CO-M (for ZPA & ZPB), CO-F, CO-H CO <sub>2</sub> -L, CO <sub>2</sub> -M, CO <sub>2</sub> -H
	+8.08±0.1 V	CH <sub>4</sub> -L, C H <sub>4</sub> -M, C H <sub>4</sub> -H
	+12±0.1 V	NO-H, CO-M (for ZPG)
	+9.05±0.1 V	SO <sub>2</sub> -BH

\*1: The type of detector is indicated on the label on the detector.

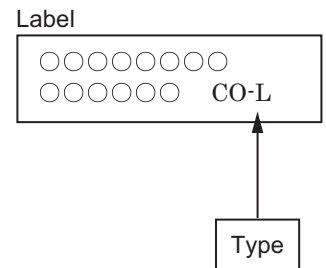

---

- Replacement

- Notes

- The AMP board is populated with components necessary for each detector. When you order the detector unit for replacement, therefore, inform a) the serial number of the gas analyzer, b) the serial number of the detector, and c) the detector type.
    - Turn off the analyzer before replacing the detector unit. Otherwise, the electronic components may get damaged.

- a) Block cell:

- 1. Remove the screws on the detector unit side to separate the block cell assy and the detector unit from the light source unit.
    - 2. Remove the screws on the block cell assy side to separate it from the detector unit.
    - 3. Replace the detector unit, and set up the three parts again.

When re-assembling, set the window assy into the block cell parallelly to ensure the airtightness.

- b) Pipe cell:

- 1. Remove the screws on the base plate to remove the detector unit.
    - 2. Fix the new detector on the base plate with the screws.

- After replacement

- 1. Check that the following three values meet the requirements shown in the Table on the previous page.
    - Voltage between the terminals DV1 and GND on the AMP board
    - Count value while flowing the zero gas
    - Resistance J1–J4 and the resistance J2–J3 of the amp board
  - 2. Carry out the zero calibration and the span calibration.

## 2.5 Built-in O<sub>2</sub> sensor (magnetic type)

- Possible troubles occur on this part:

- Damage of the O<sub>2</sub> sensor

- Symptoms: the reading for O<sub>2</sub> is zero, and it does not change when the span gas is fed.

- Check the O<sub>2</sub> input voltage

- 1. Disconnect the O<sub>2</sub> sensor cable (CN16) on the main board.
    - 2. By using a digital voltmeter, measure the voltage between the connectors 1–2. Check if the voltage is 0 V for zero gas, and 0.5–1 V for span gas. If there is no difference in voltage between zero gas and span gas, the O<sub>2</sub> sensor is failed.

- Replacement

- 1. Turn off the analyzer before replacing the sensor.
  - 2. Pay attention not to let the O<sub>2</sub> sensor case contact the analyzer case because the O<sub>2</sub> sensor case is used as 0V line of the power supply although the power supply mounting plate is attached for insulation.
  - 3. Carry out zero calibration and span calibration.

GND (Main board CN16 No. 2)

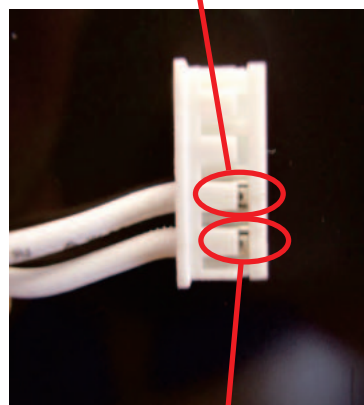

+ (Main board CN16 No. 1)

---

## 2.6 Built-in O<sub>2</sub> sensor (galvanic type)

- Recommended replacement cycle:  
2 years
- Possible troubles occur on this part:  
Sensor deterioration  
Symptoms: span drift or unstable readings  
Check: Disconnect the cable from CN16 on the main board. Connect a digital voltmeter on the both ends of the connector of the O<sub>2</sub> sensor side. If the voltage while flowing the atmospheric air is 10 mV or less, the sensor needs to be replaced.
- Replacement:  
Refer to the instruction manual. Carry out the zero and span calibration for O<sub>2</sub> sensor.
- Sensor life:  
The sensor deteriorates with age, regardless if it is used or not. The sensor can be used until the output under the atmospheric air of normal temperature and pressure becomes less than 70% of the initial value.  
The design life of the sensor is expressed as multiplication of the O<sub>2</sub> concentration (vol%) and the time (h).  
Where: temperature: 20°C, humidity: 60 vol%RH, atmospheric pressure: 1013 hPa  
Theoretically estimated replacement cycle of the galvanic O<sub>2</sub> sensor (KE-25) used in this gas analyzer is 450,000 vol%h. Based on this estimate, if you continuously measure the oxygen of 25 vol%, the replacement cycle should be:  
$$450,000 \text{ vol\%h} \div 25 \text{ vol\%} \div 24 \text{ h/day} \div 365 \text{ days/year} \approx 2.05 \text{ year}$$

## 2.7 PCB

\* Refer to Appendix 3: PCB component layout.

### 1) Main board

- Voltage check

Check terminal	Check voltage	Contents
TPVC1-TPVS1	+5 ±0.3 V	Digital 5 V
TP15-TPG1	+15 ±0.5 V	Analog 15 V
TPN15-TPG1	-15 ±0.5 V	Analog -15 V
TPVH1-TPVS1	+3.3 ±0.2 V	Digital 3.3 V
TPVL1-TPVS1	+1.25 ±0.1 V	Digital 1.25V

#### Notes

- The main board is programmed according to the ordered specification. When you order the replacement PCB, provide the serial number of the analyzer so that you can get the one properly programmed.
  - Turn off the analyzer before replacement. Otherwise, the electronic components may get damaged.
- 
- After replacement:
    1. Carry out the voltage check as shown above.
    2. Adjust the contrast of the display.  
Menu mode > Parameters > Contrast  
Refer to the instruction manual for the detail.
    3. Check if all the keys work properly.

---

## 2) AIO board

- After replacement:  
Check the output. Adjust the output as needed. Refer to the instruction manual for the detail.

## 3) Main power supply board

- Recommended replacement cycle:  
5 years  
Check: a) leak of electrolyte from the electrolytic capacitor, b) voltage

Check terminal	Check voltage	Contents
+24V-GND	+24.0±0.3 V	Input
VCC-VSS	+5.0±0.3 V	digital
+15V-GND	+15.0±0.5 V	analog
-15V-GND	-15.0±0.5 V	analog

- After replacement:  
Carry out the voltage check as shown above.

## 4) Light source power supply board

Check: voltage

Check terminal	Check voltage	Contents
VIN-GND1 (Input voltage)	+24.0±1.0 V	common for ZPA, ZPB and ZPG
VOUT-GND2 (Output voltage)	+15.0±0.5 V	for ZPA and ZPB
	+9.0±0.5 V	for ZPG

- After replacement:  
Carry out the voltage check as shown above.

## 2.8 LCD

- Service life:  
30,000 hours (when continuously used)
- Possible troubles occur on this part:  
Display deterioration, backlight failure  
Symptoms: black screen, dim screen, flickering screen  
Check: Adjust the contrast of the display.  
Check the connection with the main board. (Disconnect the cable and then connect it again.)
- Replacement:  
Turn off the analyzer. Disconnect the cable and replace the LCD.
- After replacement:  
Adjust the contrast. Refer to the instruction manual for the detail.

## 2.9 Switched-mode power supply (SMPS)

- Recommended replacement cycle:  
5 years
- Possible troubles occur on this part:  
Power failure  
Symptoms: black screen, no output  
Check: Check if there are any short circuit. Disconnect the connectors from the output terminals. Turn on the analyzer and measure the voltages on each terminal. If the voltage does not meet the rated value shown in the table below, the power supply is failed.
- Replacement:  
Turn off the analyzer before replacement. Disconnect the cables from the main board and the power switch, and replace the power supply.
- After replacement:  
Check the power supply voltage on the main board.

ZWS50BAF-24 (common for ZPA, ZPB & ZPG)

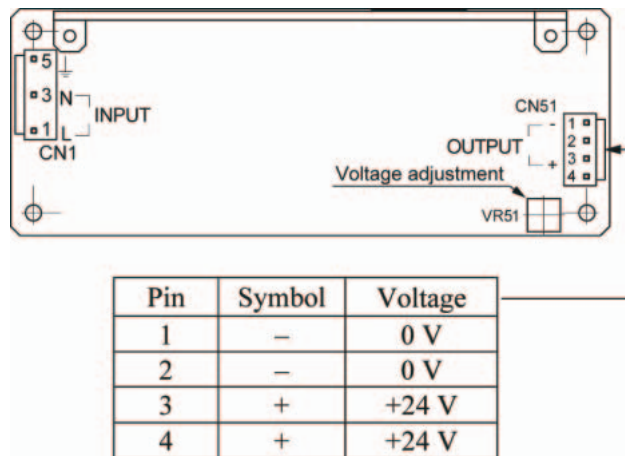

LFA10F-12 (only for ZPB & ZPG)

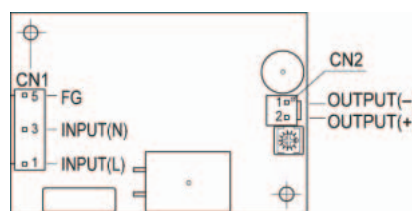

Pin	Voltage
1	0 V
2	+12 V

## 2.10 Operation keys

- Possible troubles occur on this part:

Abrasion of the switches

Symptoms: no response to key operation

Check:

1. Turn OFF the power.
2. Disconnect the cables.
3. Measure the resistance of the connector of the key that does not work.
4. Check the electrical connection. If the switch is normal, the connection is made by pressing the switch, and broken by releasing the switch.

- Replacement:

1. Detach the main board and the main board mounting plate from the base of the front panel.
2. Remove two screws on the key board.
3. Replace the key board.
4. Set up the parts.
5. Connect the cables.

- After replacement:

Check that all the keys work properly.

Allocation of Connector

Connector pin No.	Key name
2-10	MODE
3-10	>
4-10	^
5-10	∨
6-10	ESC
7-10	ENTER
8-10	ZERO
9-10	SPAN

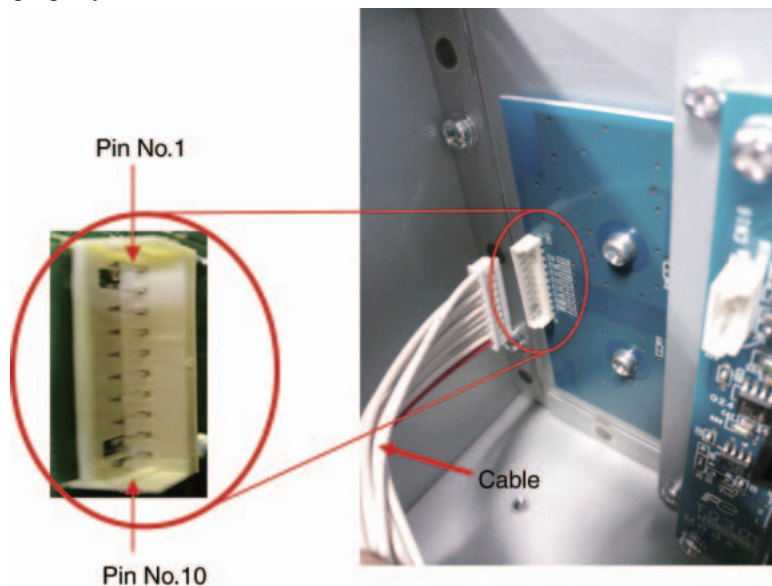

---

## 2.11 Solenoid valve

- Recommended replacement cycle:  
3 years  
Symptoms: short-circuit or disconnection due to the solenoid coil burn out, or wear of the core
- Replacement:  
Turn off the analyzer before replacing the sensor. Disconnect the wires and tubes. Replace the solenoid valve.
- After replacement:  
Carry out zero calibration and span calibration.

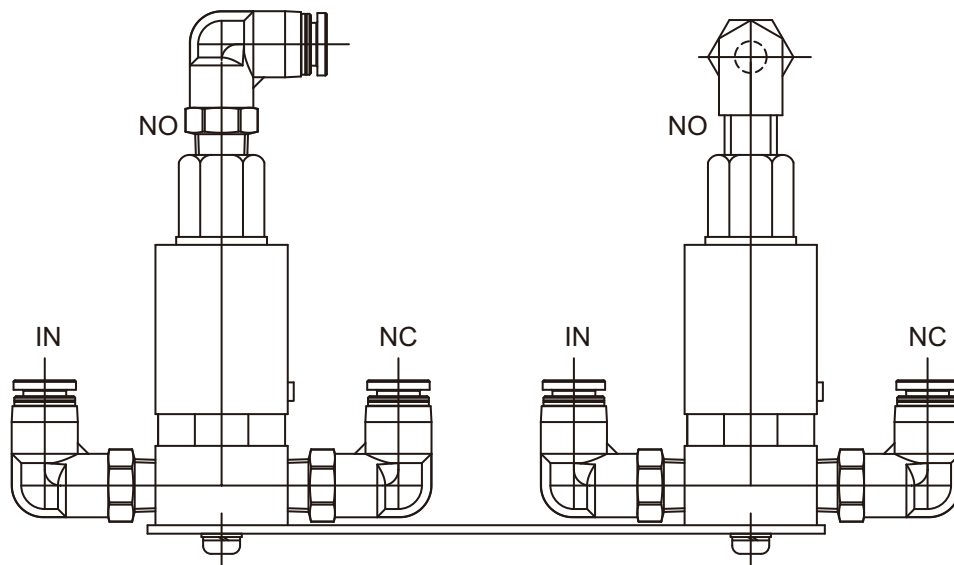

## 2.12 Filter

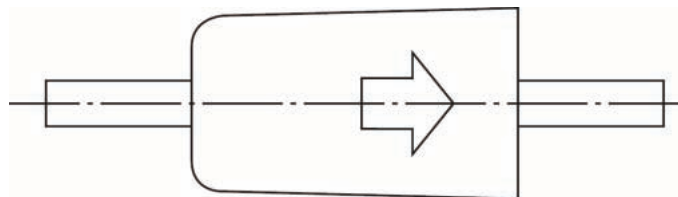

\*When you replace the solenoid valve, be sure to replace the filter as well.

- Recommended replacement cycle:  
3 years  
Symptom: filter get clogged and gas won't pass through
- Replacement:
  1. Turn off the analyzer before replacement.
  2. Remove the hose clamp, and then pull out the hose from the filter.
  3. Put the hose through the new filter, and then attach the hose clamp.
- After replacement:  
Carry out zero calibration and span calibration.







# 3. FACTORY MODE

## 3.1 How to go to factory mode

Point the cursor to “6. To Factory Mode” by using the  or  key on the Maintenance Mode screen and press the  key. Then, the password input screen appears.

Maintenance Mode	Select operating item
1. Sensor Input Value 2. Error Log 3. Cal. Log 4. Output Adj. 5. Other Parameter 6. To Factory Mode	



By using  or  key for numerical value editing and the  key for digit selection, enter the password “4043”, and press the  key. The Factory Mode initial screen appears.

Input Password: 4043
----------------------



The items you can edit are:

- 4. Option
- 5. Pressure
- 12. Others
- 14. Coefficient
- 16. Sample Switch

All the other items can only be viewed.

Factory Mode	Select operating item
1. PILC Code 2. Ch No. 3. Ch Data 4. Option 5. Pressure 6. Linearization 7. Temperature 8. Output SW 9. DIO SW	10. Memory Access 11. A/D Data 12. Others 13. Interference 14. Coefficient 15. Calculation 16. Sample Switch



Point the cursor to the item you want to edit or view, and press the  key.

If you want to return to the Factory Mode initial screen, press the  key.

Pressing the  key again allows you to return to the maintenance mode screen.

Into each parameter screen

## 3.2 Zero limit

- You can switch whether or not to show the values below zero of the measured value.
  - OFF: Values below zero are not displayed
  - ON: Values below zero are displayed
- The default setting is “OFF”.

**If you turn “ON” the zero limit to check the indication during analyzer adjustment, do not forget to turn it “OFF” after adjustment.**

Factory mode > 12. Other parameters > Zero limit

Factory mode initial screen  
The cursor is in 12.



Point the cursor to “Zero limit” and press the <sup>ENT</sup> key.  
The setpoint (ON or OFF) is inverted.

Factory Mode Others	Select an item
<input checked="" type="checkbox"/> ZERO limit	OFF
Range limit	ON
AO No.	12
Language	ENG
ZERO gas	Cylinder
Protocol	MO
Varied Range	ON
DIO No.	0



By using the <sup>^</sup> or <sup>v</sup> key, switch between ON and OFF, and press the <sup>ENT</sup> key. If you want to cancel the change, press the <sup>ESC</sup> key before pressing the <sup>ENT</sup> key.

Factory Mode Others	The value under zero is disappeared
ZERO limit	<b>OFF</b>
Range limit	ON
AO No.	12
Language	ENG
ZERO gas	Cylinder
Protocol	MO
Varied Range	ON
DIO No.	0

### 3.3 Range limit

- You can switch on and off of the limiter applied on the measured value used for O<sub>2</sub> correction and for calculating the moving average.
  - ON: indication and output of the measured value is limited up to 110% of FS
  - OFF: the measured value is indicated and transmitted up to limit of the display.
- The default setting is “ON”.

Factory mode > 12. Other parameters > Range limit

Factory mode initial screen  
The cursor is in 12.



Point the cursor to “Range limit” and press the <sup>ENT</sup> key.  
The setpoint (“ON” or “OFF”) is inverted.

Factory Mode	Select an item
Others	
ZERO limit	OFF
<input checked="" type="checkbox"/> Range limit	ON
AO No.	12
Language	ENG
ZERO gas	Cylinder
Protocol	MO
Varied Range	ON
DIO No.	0



By using the <sup>^</sup> or <sup>v</sup> key, switch between “ON” and “OFF”, and press the <sup>ENT</sup> key. If you want to cancel the change, press the <sup>ESC</sup> key before pressing the <sup>ENT</sup> key.

Factory Mode	Range limit is usable
Others	
ZERO limit	OFF
Range limit	<b>ON</b>
AO No.	12
Language	ENG
ZERO gas	Cylinder
Protocol	MO
Varied Range	ON
DIO No.	0

### 3.4 Calibration coefficient

- This menu allows you to change the coefficient for zero calibration and for span calibration.

Factory mode > 14. Coefficient

Factory mode initial screen  
The cursor is in 14.



- “R1 and R2” means the range 1 and the range 2 respectively.
- The third column from left shows the zero calibration coefficient, and the fourth shows the span coefficient.

Factory Mode coefficient			
Ch1	R1	01.00000	1.0000
	R2	01.00000	1.0000
Ch2	R1	01.00000	1.0000
	R2	01.00000	1.0000
Ch3	R1	01.00000	1.0000
	R2	01.00000	1.0000
Ch4	R1	01.00000	1.0000
	R2	01.00000	1.0000
Ch5	R1	+0000	1.0000
	R2	+0000	1.0000



Select the component and range you want edit, and press the key. Use the and key to change the value, and the key to select the digit, and press the key. If you want to cancel the change, press the key before pressing the key.

Factory Mode coefficient			
Ch1	R1	01.00000	1.0000
	R2	01.00000	1.0000
Ch2	R1	01.00000	1.0000
	R2	01.00000	1.0000
Ch3	R1	01.00000	1.0000
	R2	01.00000	1.0000
Ch4	R1	01.00000	1.0000
	R2	01.00000	1.0000
Ch5	R1	+0000	1.0000
	R2	+0000	1.0000

### 3.5 A/D conversion value

Factory mode > 11. A/D data

No	Count	No	Count	No	Count
0	Ch1 input value	8	Temperature sensor 4	16	Ground
1	Ch2 input value	9	Temperature sensor 5	17	Resistance 1-2
2	Ch3 input value	10	Resistance 1-1	18	Resistance 2-2
3	Ch4 input value	11	Resistance 2-1	19	Resistance 3-2
4	Ch5 input value	12	Resistance 3-1	20	Resistance 4-2
5	Temperature sensor 1	13	Resistance 4-1		
6	Temperature sensor 2	14	Pressure		
7	Temperature sensor 3	15	Reference voltage		

Factory mode initial screen  
The cursor is in 11.



Factory Mode A/D Data					
NO	Count	NO	Count	NO	Count
0	65444	8	44857	16	7645
1	56779	9	45667	17	47888
2	66982	10	37889	18	47893
3	85663	11	37465	19	47261
4	6855	12	37897	20	47893
5	44939	13	37665		
6	44756	14	42367		
7	44869	15	40029		

Check that the A/D values during dry zero gas flow fall under the following range.

- No. 0 (Infrared ray component 1)      35,000 to 80,000 (ZPA) or 350,000 to 800,000 (ZPB & ZPG)
- No. 1 (Infrared ray component 2)      35,000 to 80,000 (ZPA) or 350,000 to 800,000 (ZPB & ZPG)
- No. 2 (Infrared ray component 3)      35,000 to 80,000 (ZPA) or 350,000 to 800,000 (ZPB & ZPG)
- No. 3 (Infrared ray component 4)      35,000 to 80,000 (ZPA) or 350,000 to 800,000 (ZPB & ZPG)
- No. 4 (O<sub>2</sub> sensor input)                18,000 to 22,000

Ignore the values for the channels (components) you do not use.

## 4. ERROR CRITERIA

\* This section covers the error judgement criteria for error codes.

For the contents of errors, refer to Instruction Manual.

Error No.	Contents	Criteria
Error 1	Light source or motor is faulty	The optical chopper (sector motor) interrupts the detector signal to generate the rectangular wave. The analyzer emits the error 1 when rectangular wave is not generated or the waveform is irregular.
Error 2	Detector failure	When the hot wire resistances (voltage) after A/D conversion is out of the following range, the analyzer emits the error 2. $10,000 \leq \text{No. 17-20} \leq 59,999$ The resistances monitored are: No.17 (1-2), No. 18 (2-2), No. 19 (3-2), and No.20 (4-2). You can check their A/D converted value in "A/D data" of the Factory Mode.
Error 3	A/D conversion signal is faulty.	When the A/D conversion value of the reference voltage is out of the following range, the analyzer emits the error 3. $35,000 \leq \text{No. 15} \leq 80,000$ (ZPA) or $350,000 \leq \text{No. 15} \leq 800,000$ (ZPB and ZPG)
Error 4	Zero calibration is not within the allowable range.	Infrared component: $0.5 \leq \text{zero calibration coefficient} \leq 5$ $\text{O}_2$ : $-2,000 \leq \text{zero calibration coefficient} \leq 12,000$
Error 5	A amount of zero calibration is over 50% of full scale.	This error occurs in the following condition. $50\% \text{ of FS} <$ $(\text{Zero calibration concentration set value}) - (\text{current display})$
Error 6	Span calibration is not within the allowable range.	When span calibration coefficient is not within the following range, error occurs. Infrared component: $0.1 \leq \text{span calibration coefficient} \leq 10$ External $\text{O}_2$ / built-in galvanic cell type $\text{O}_2$ / built-in paramagnetic type $\text{O}_2$ : $0.5 \leq \text{span calibration coefficient} \leq 16$ Zirconia $\text{O}_2$ : $6,000 \leq \text{span calibration coefficient} \leq 32,000$
Error 7	An amount of span calibration is over 50% of full scale.	This error occurs in the following condition. $50\% \text{ of FS} <$ $(\text{Span calibration concentration set value}) - (\text{current display})$
Error 8	Measured values fluctuate to much during zero and span calibration	Infrared component, built-in paramagnetic type $\text{O}_2$ : If measured values are not stabilized in 60 seconds (change of more than 100 counts is continued) Built-in galvanic cell type $\text{O}_2$ , Zirconia $\text{O}_2$ : If measured values are not stabilized in 60 seconds (when the fluctuation of Input voltage by 100 mV or larger continues)
Error 9	Calibration is abnormal during auto calibration	Error corresponding to No. 4 to No.8 occurs during auto calibration.
Error 10	Output cable connection is improper.	Error occurs if no response is made from the digital output IC.

Points to be checked upon errors

Error No.	Points to be checked	page
Error No. 1	Sector rotation, light source, and detector signal on amplifier board	—
Error No. 2	<ul style="list-style-type: none"> <li>• Factory mode &gt; 11. A/D data &gt; No. 17 to No. 20</li> <li>• Connection between the amp board and the main board</li> </ul>	24
Error No. 3	Factory mode > 11. A/D data > No. 15 (the voltage between TPVH1-TPVS1 on the main board)	24
Error No. 4	5. TROUBLESHOOTING > Zero calibration error	27
Error No. 5		
Error No. 6	5. TROUBLESHOOTING > Span calibration error	27
Error No. 7		
Error No. 8	5. TROUBLESHOOTING > Zero calibration error and Span calibration error	27
Error No. 9		
Error No. 10	<ul style="list-style-type: none"> <li>• Connection between DIO boards</li> <li>• Connection between the DIO boards and the AIO board</li> </ul>	—

## 5. TROUBLESHOOTING

---

- Zero calibration error
  - Check that a specified amount of zero gas is supplied to the analyzer.
    - ⇒ If the gas amount is deficient, check the piping for leaks and repair them.
  - Detector check
    1. Check if the voltage DV1-GND of the AMP board are as specified (p.13).
    2. Record the voltage TP1-SC of the AMP board during the zero gas flow.
    3. Check the count values (“sensor input value” in the maintenance mode) during the zero gas flow. (p. 13)
  - Check the voltages on the main board (p. 15) and the voltages on the switched-mode power supply (p.17).
  
- Span calibration error
  - Check that the span gas concentration and span calibration setting value agree with each other.
  - Check that a specified amount of span gas is supplied to the analyzer.
    - ⇒ If the gas amount is deficient, check the piping for leaks and repair them.
  - Check if the zero calibration can be properly performed.
    - ⇒ If not, follow the instructions in “Zero calibration error” above.
  - Detector check
    1. Record the voltage TP1-SC of the AMP board during the span gas flow.
    2. Check the count values (“sensor input value” in the maintenance mode) during the span gas flow. (p. 13)
  
- Drift
  - Check that specified amount of gas is supplied to the analyzer.
    - ⇒ If the gas amount is deficient, check the piping for leaks and repair them.
  - Check that the cell window, O-ring, detector window and cell inside are not contaminated.
    - ⇒ Clean the cell and window. Replace parts.
  
- Readings are too high or too low.
  - Check that a large quantity of interference components (moisture and/or CO<sub>2</sub>) is not contained in the sample gas.
    - ⇒ Ask the user what components are contained in sampling gas.
  
- Readings does not increase
  - Check that specified amount of gases are supplied to the analyzer.
    - ⇒ If the gas amount is deficient, check the piping for leaks and repair them.
  - Check that zero and span calibration can be performed.
    - ⇒ If possible, sample the gas and check for the cause of the problem.
      - If not possible, follow the instructions in “Zero calibration error” and “Span calibration error” above.

● Recording the values at error

When trouble occurs, be sure to sample the following data.

Supply the gas given in Table and sample the measured value of measurement screen, sensor input values in maintenance mode.

Supplied gas	Gas concentration, composition		Span calibration concentration set value	Measurement display		Sensor input value in maintenance mode
Zero gas	Range 1					
	Range 2					
Span gas	Range 1					
	Range 2					
2°C Wet gas						
Sample gas			_____	Range 1		
				Range 2		

- If you do not use the second range, leave the cells for the Range 2 blank.
- If troubles occur in multiple components, take a record for each component.
- If troubles occur in the O<sub>2</sub> analyzer, add a column for the “zero calibration concentration set value” that corresponds to the "span calibration concentration set value".

“Coefficient” in the factory mode

Channel No.	Component	Range value		Zero coefficient	Span coefficient
Ch1		Range 1			
		Range 2			
Ch2		Range 1			
		Range 2			
Ch3		Range 1			
		Range 2			

- Sampling system diagram  
If sampling system diagram is prepared, report the drawing number.  
If sampling system diagram is not prepared, report the sketch.

**If there are any other items you think necessary for solving the trouble, provide their data as well.**

## 6. ADJUSTMENT FOR HEAT TREATMENT FURNACES

### What is the adjustment for heat treatment furnaces?

If, in plant gases to be measured, a large amount of other lower-molecular-weight gases than nitrogen ( $N_2$ ) such as hydrogen ( $H_2$ ), or a large amount of other higher-molecular-weight gases than nitrogen ( $N_2$ ) such as argon (Ar) are contained, it is known that the calibration curve (output performance to gas concentration) of gas analyzers will be affected (pressure broadening).

In such a case, analyzer is adjusted with gases similar to plant gas compositions in manufacturing (adjustment by scale gas). After this adjustment, the analyzer is checked the calibration curve with  $N_2$  balance gas (calibration curve by check gas). Graphs with these calibration curves drawn are attached to products to be supplied.

Since measurement in a heat treatment furnace has much gas of such composition, it is the adjustment for heat treatment furnaces.

In order to perform exact measurement, there are two methods in span calibration:

Composition of the standard gas for span calibration used for each method and its method are explained using an example:

For the standard gas for zero calibration, use dry  $N_2$  in any case so that zero point will not be affected.

#### <Example>

Assume that a 0 – 1%  $CO_2$  meter of the infrared ray gas analyzer measures  $CO_2$  contained in plant gases.

When plant gases are composed of 0.5%  $CO_2$ , 23% CO, 30%  $H_2$ , 0.2%  $CH_4$  and 46.3%  $N_2$ , either of the following is used as the span calibration standard gas.

	Standard gas type	Composition of standard gas	Method for span adjustment
1	Standard gas with the same composition as plant gases (scale gas)	0.9% to 1% $CO_2$ 23% CO, 30% $H_2$ , $N_2$ *	Directly
2	Check gas	0.9% to 1% CO balance is $N_2$	Indirectly

\* A small amount of gas like 0.2%  $CH_4$  with little effect on span calibration may be excluded from the standard gas.

### 6.1 Method for span calibration by standard gas with the same composition as plant gas

When using the standard gas with the same composition as plant gases given in 1, calibration can be performed without correction, as an error in calibration curve does not occur.

- 1) Set  $CO_2$  concentration to span calibration concentration set value.
- 2) Perform span calibration by using the operation key.

## 6.2 Method for span calibration by check gas

The method for span calibration by use of check gas (give in 2) is explained based on the example. (Since span calibration has an error of calibration curve, preset a calibration indication on the calibration curve graph attached to this analyzer for indirect calibration.)

- 1) The following calibration curve graph is attached to the test results for the product. In graph, the calibration curve by the scale gas (that is similar to plant gas and determines scales of this analyzer) and the calibration curve by the check gas that is adjusted by the scale gas (gas of simple composition of N<sub>2</sub> balance gas to facilitate the analyzer check) are drawn.

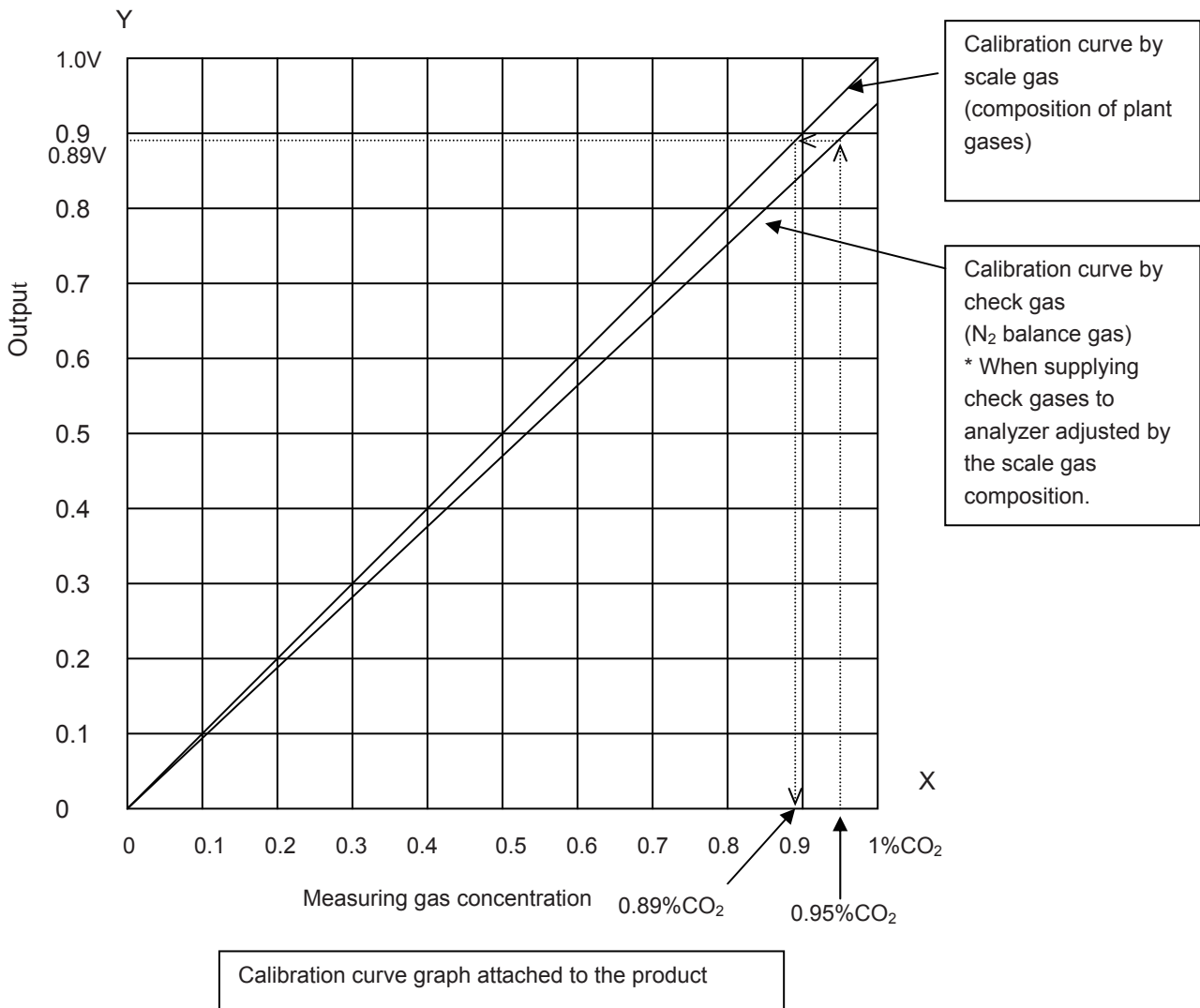

- 2) When using 0.95% CO<sub>2</sub> and remainder N<sub>2</sub> (check gas) as calibration gas, In graph, a point of 0.95% on X-axis should be stretched to upward, draw a line toward Y-axis from the cross point with the check gas calibration curve. From the cross point with calibration curve on the scale gas composition, 0.89% or equivalent values can be obtained.
- 3) Set this point (0.89%) to the span calibration concentration of the calibration concentration set value.
- 4) Supply 0.95% check gas to perform span calibration. Then, the concentration value is corrected to 0.89%. Measurement suited to actual plants can be performed by this error correction of calibration curve.

## 7. MOISTURE INTERFERENCE ADJUSTMENT

Moisture interference adjustment is only for NO analyzer and SO<sub>2</sub> analyzer.

Purpose : Adjust the light control plate in between the three layer detector so that moisture interference becomes close to zero.

Procedure : 1) To start adjustment, set the light control plate at the same height (10 to 15mm upper than (c): upper end of the fixing plate) as in the right figure (a).

- 2) Enter "Maintenance mode", "1.Sensor Input".
- 3) Flow zero gas and gas contained water of 2°C (N<sub>2</sub> balance) to read the count value of each gas. Respectively replace the read values (in NO, SO<sub>2</sub> component) of Zero with Z<sub>a</sub> and Moisture with H<sub>a</sub>.

4) Set the light control plate at the same height (1 to 6mm lower than (c): upper end of the fixing plate) as in the right figure (b).

- 5) Flow the gas in the same manner in (3) to read the count value of each gas. Respectively replace the read values of Zero with Z<sub>b</sub> and Moisture with H<sub>b</sub>.

6) Calculate the Zero point, Z<sub>x</sub> (count value) as following.

$$Z_x = \left( \frac{(Z_b \times H_a) - (Z_a \times H_b)}{(Z_b - Z_a) - (H_b - H_a)} \right)$$

7) Move the light control plate up and down while flowing zero gas, and adjust its position so that the value becomes equal to Z<sub>x</sub> calculated in (6).

When the position of the panel is set, fasten it with fixing screw.

- 8) After Zero/Span calibration, flow water of 2°C, and check that a deviation is within 1%FS.
- 9) After confirmation in (8), perform paint lock of the fixing screw of the light control panel.

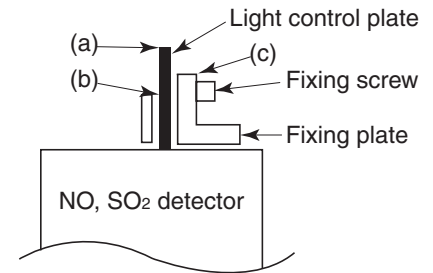

# APPENDIX 1. MEASURING PRINCIPLE DIAGRAM

## Principle Diagram of Infrared Type Measurement ( $\text{NO}$ , $\text{SO}_2$ , $\text{CO}_2$ , $\text{CO}$ , $\text{CH}_4$ )

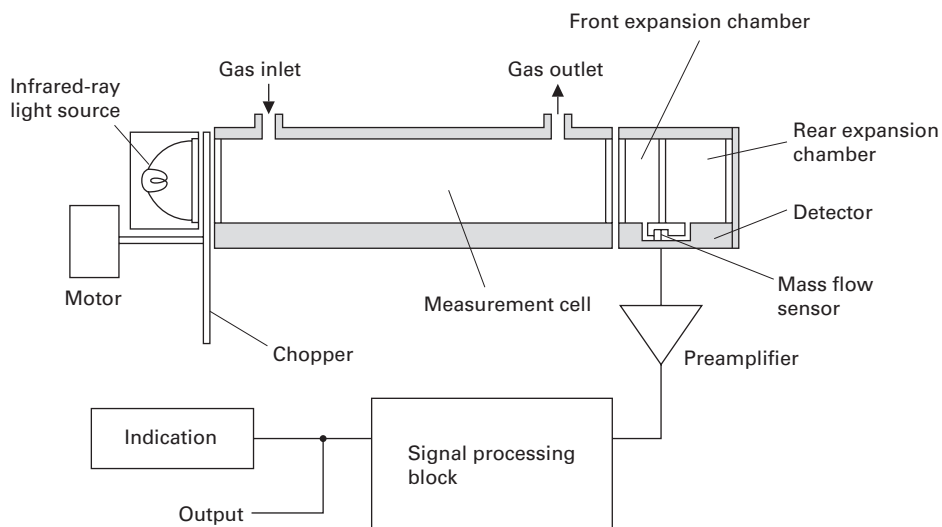

## Principle Diagram of Magnetic Force Type Measurement ( $\text{O}_2$ )

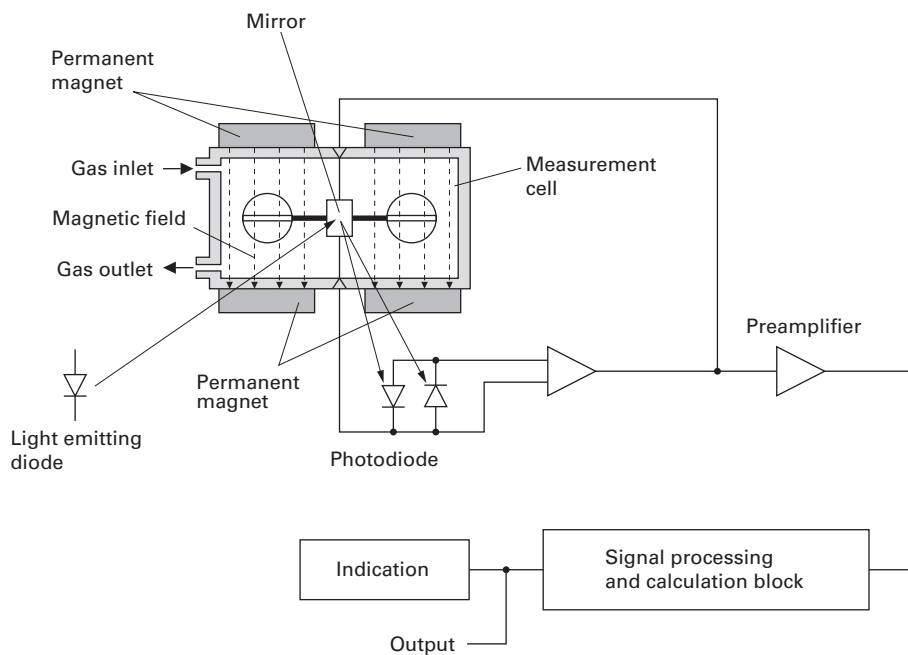

## Principle Diagram of Galvanic cell Type Measurement ( $\text{O}_2$ )

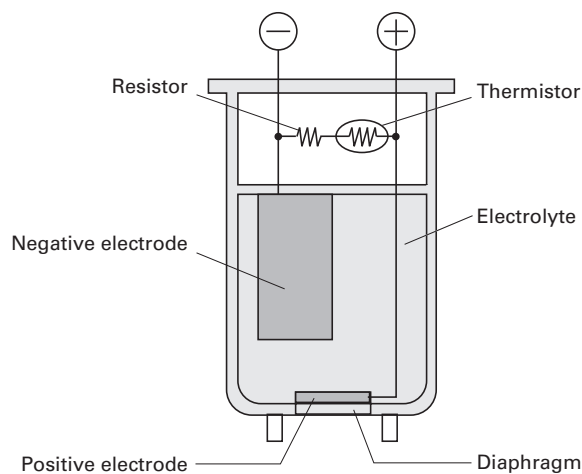

# APPENDIX 2. DATA FLOW DIAGRAM

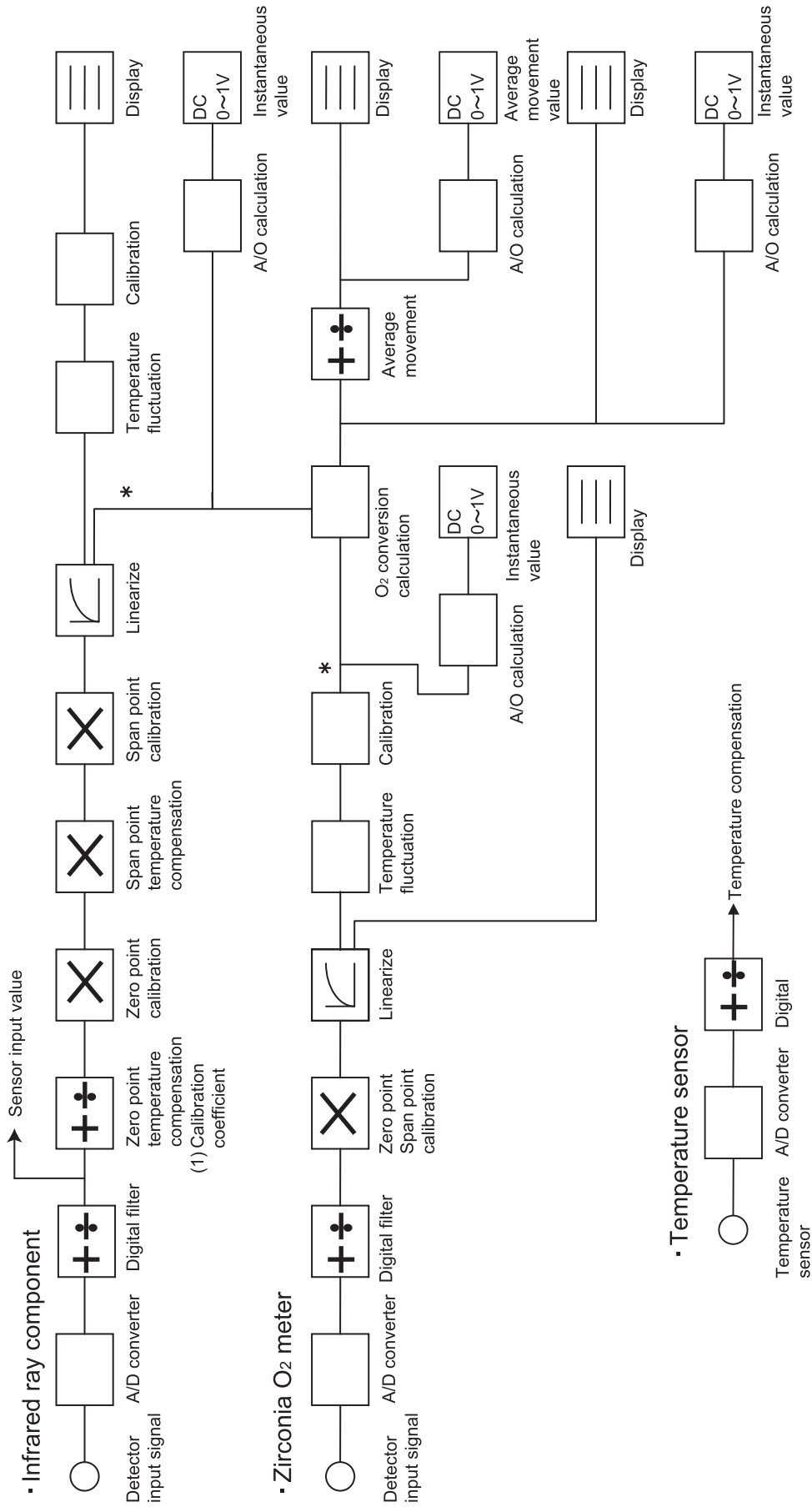

Note 1) Asterisk mark \* indicates "Hold point".  
Computation is stopped during the hold.

# APPENDIX 3. PCB COMPONENT LAYOUT

## Main board

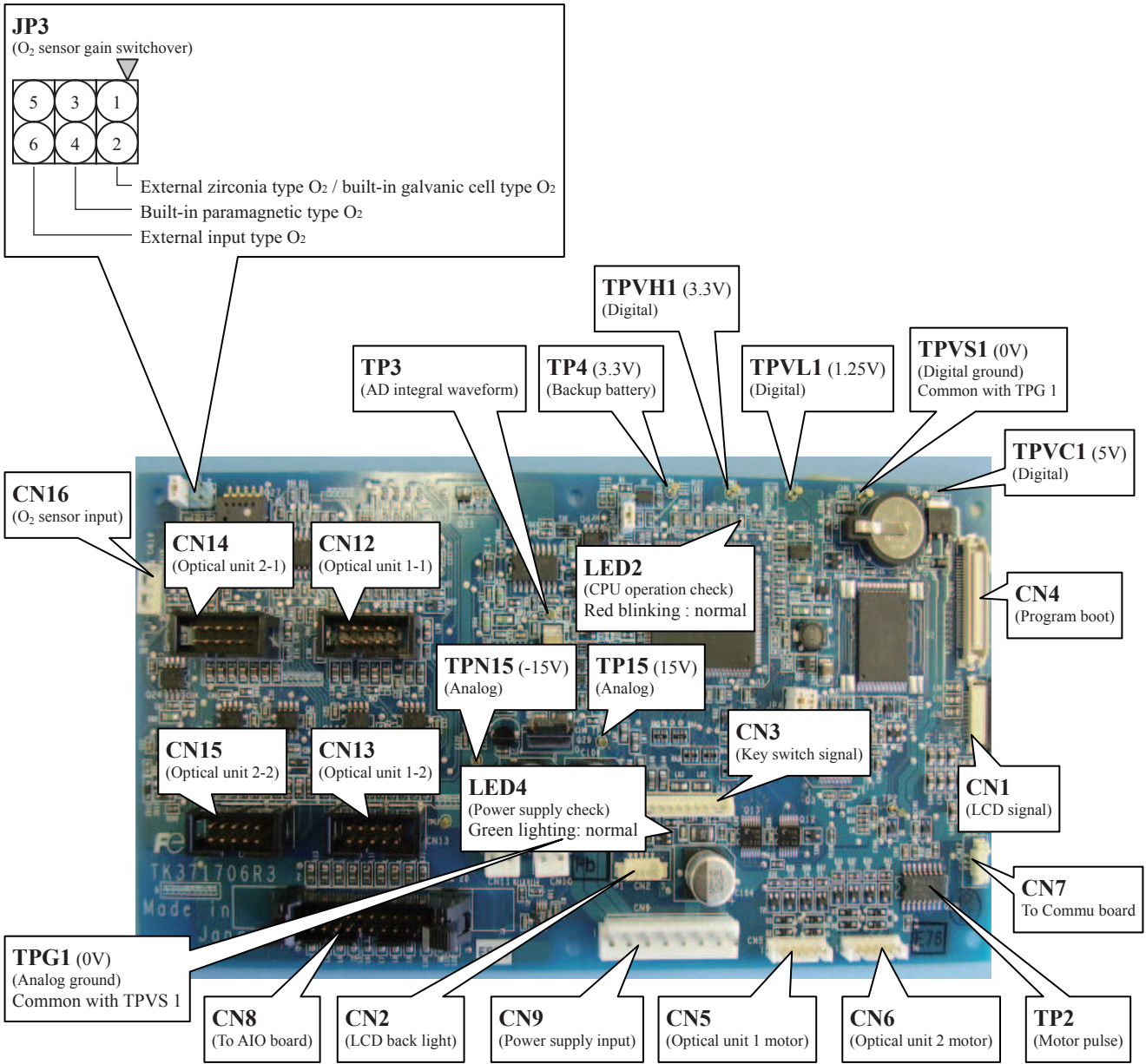

## AIO board

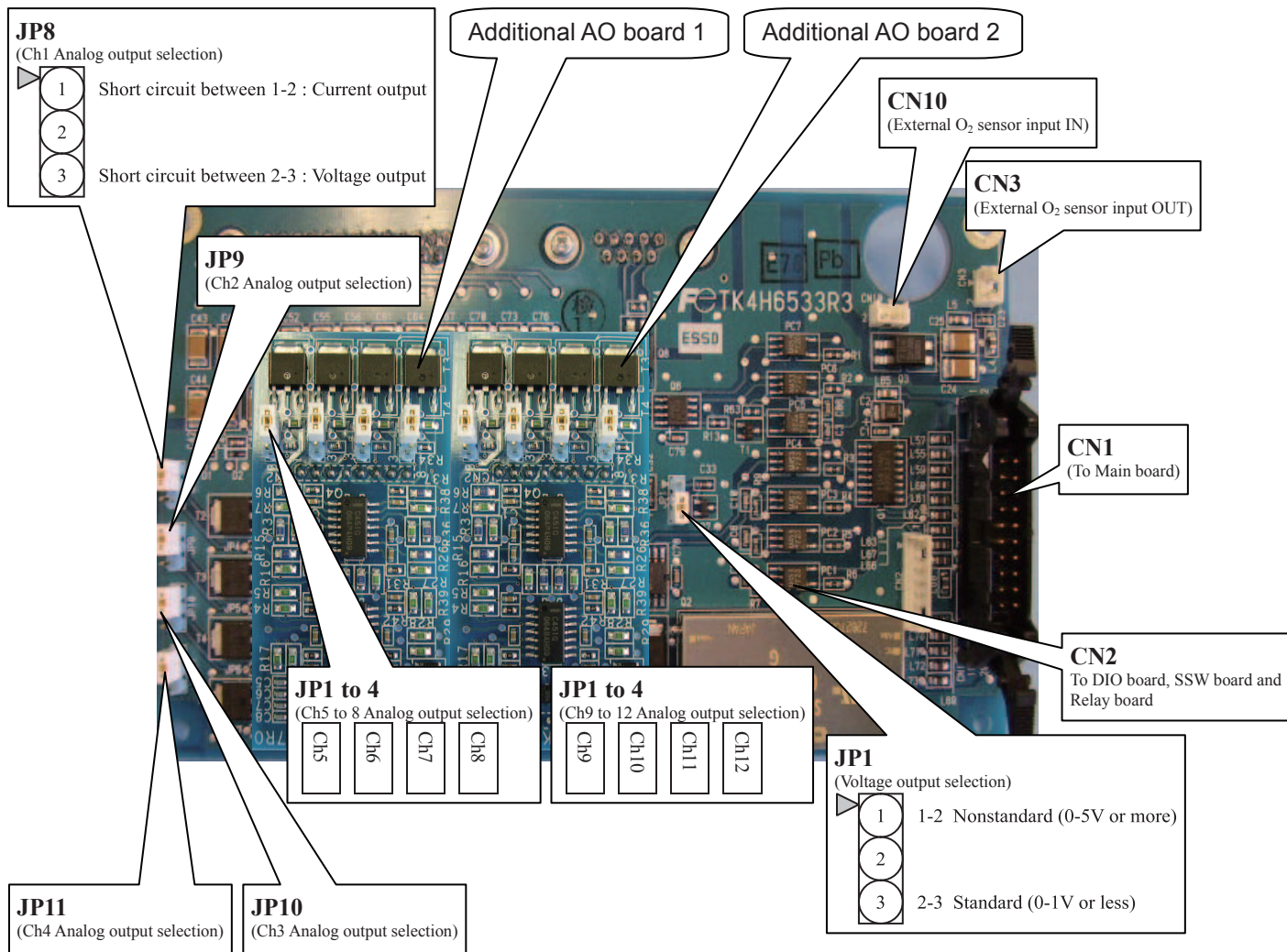

## Amplifier board

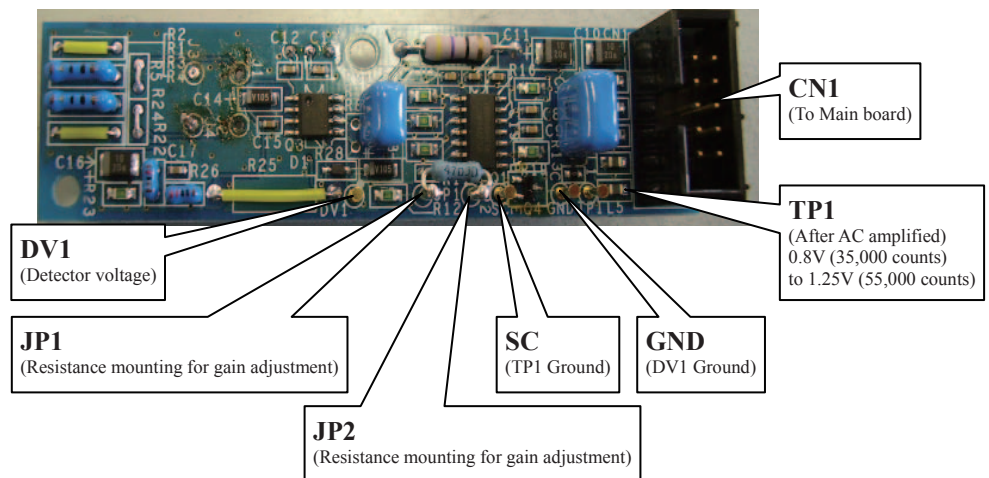

**Main power board**

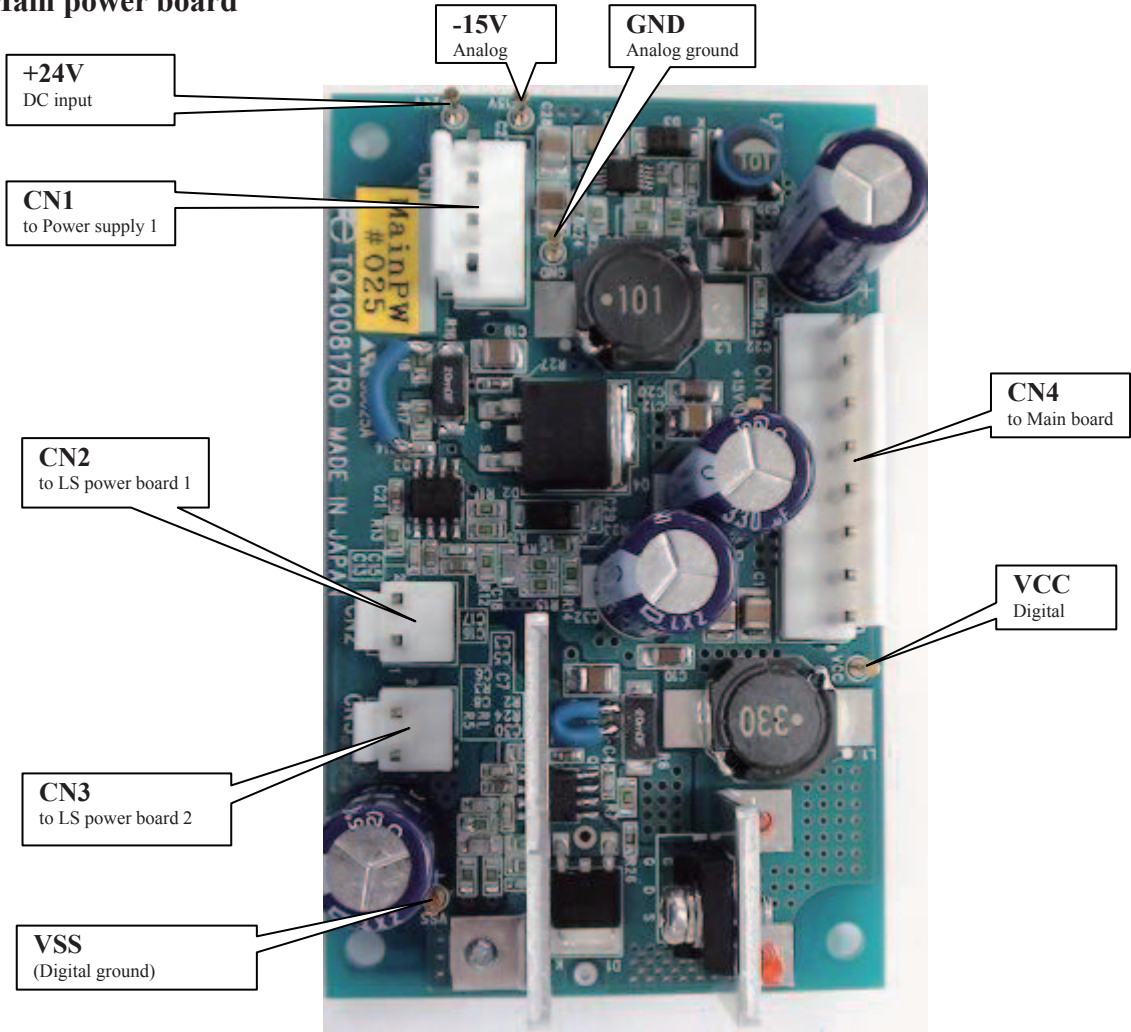

**Light source power board**

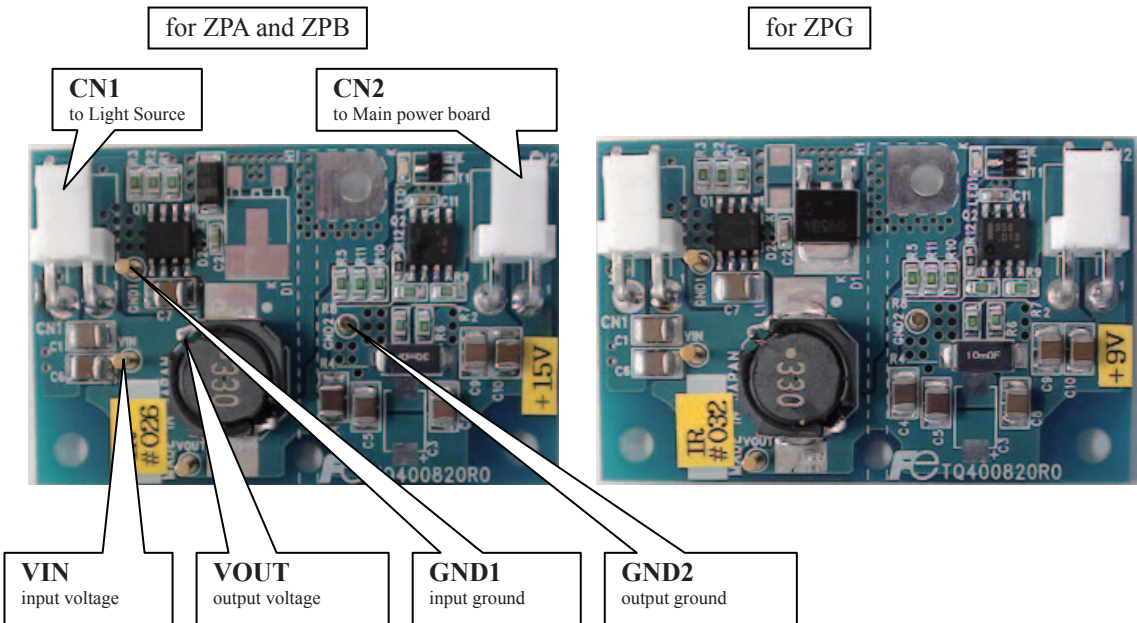

---

## **Fuji Electric Co., Ltd.**

**Instrumentation & Sensors Planning Dept.**

1, Fuji-machi, Hino-city, Tokyo 191-8502, Japan

[www.fujielectric.com](http://www.fujielectric.com)

Phone: +81-42-514-8930 Fax: +81-42-583-8275

[www.fujielectric.com/products/instruments/](http://www.fujielectric.com/products/instruments/)

---